

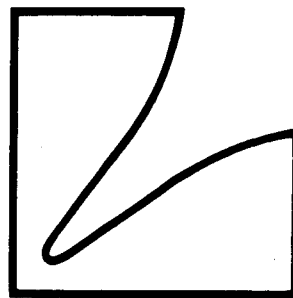

For more Hi-Fi manuals and set-up information  
please visit [www.hifiengine.com](http://www.hifiengine.com)

# SERVICE MANUAL



Compact Disc Player

# D-107u

- Regarding the disassembly for the cabinet section and CD mechanical section, please refer to the D-105u Service Manual (Part No. 68P20520W02).
- Disassemblyの〈Cabinet Section〉と〈CD Mechanism Section〉の項目については、D-105u (68P20520W02) のサービスマニュアルを参照願います。

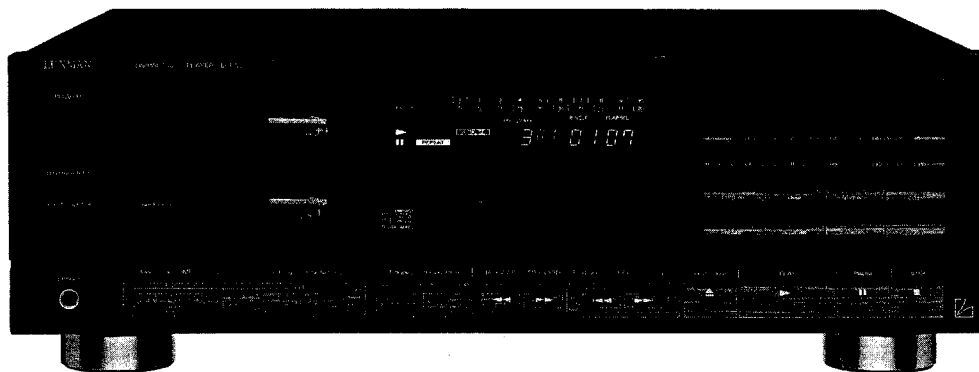

---

## Contents

---

Specifications .....	3
Reference Illustrations .....	4 to 5
Controls, Switches, Jacks & Terminals .....	6 to 7
Connection Guidelines .....	8
Operation Guidelines .....	9 to 12
Care & Maintenance .....	13
Adjustment Procedures .....	14 to 16
Adjustment Locations .....	17 to 20
Block Diagram .....	21 to 22
Schematic Diagram .....	23 to 44
Parts Layout on P.C. Boards and Wiring Diagram .....	45 to 52
Electrical Parts List .....	53 to 57
Cabinet Assembly Parts List .....	58
Exploded View (Cabinet) .....	59 to 61
Exploded View (Mechanism) .....	62 to 63
Mechanism Assembly Parts List .....	64
Packing Assembly Parts List .....	65
Packing Method View .....	65
Semi-Conductor Lead Identifications .....	66 to 71

Additional Schematic Diagram Inserted

## Specifications

### < CD SECTION >

System .....	Optical (Compact Disc System)
Quantizing Bit Number .....	16 Bit Linear System
Channels .....	2 Channels, Stereo
Pick-up .....	Semiconductor Laser Pick-up
Output Voltage .....	2.1 V $\pm$ 1 dB
Frequency Response .....	20 Hz~20 kHz $\pm$ 2.5 dB
T.H.D. (1 kHz) .....	0.12%
S/N Ratio .....	95 dB
Dynamic Range .....	85 dB
Separation (1 kHz) .....	83 dB
Head-phone Output Voltage (1 kHz, 0 dB/8 ohm) .....	260 mV $\pm$ 1 dB
Power Supply .....	AC100 V, 50/60 Hz (JA Model Only) AC120/220/240 V, 50 Hz (AD Model Only)
Power Consumption .....	28 W
Semiconductors .....	20 IC's, 25 Transistors, 44 Diodes, 2 Zener Diodes, 2 Vacuum Tubes (JA Model Only) 20 IC's, 25 Transistors, 48 Diodes, 2 Zener Diodes, 2 Vacuum Tubes (AD Model Only)
Dimension (WxHxD) .....	469x147x342 mm (JA Model Only) 438x147x342 mm (AD Model Only)
Weight .....	12.7 kg (JA Model Only) 11.7 kg (AD Model Only)

### < COMPACT DISC >

Track Pitch .....	1.6 $\mu$ m
Modulation Frequency .....	44.1 MHz
Transfer Rate .....	4.3218 MBit/sec.
Dimension .....	80 or 120x1.2 mm



# Reference Illustrations

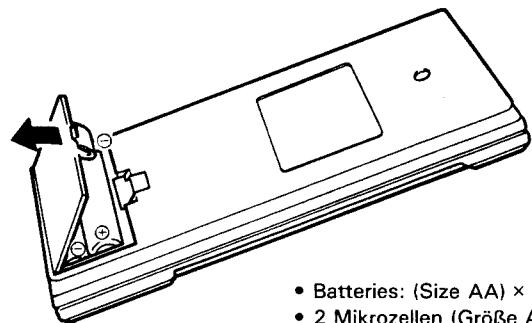
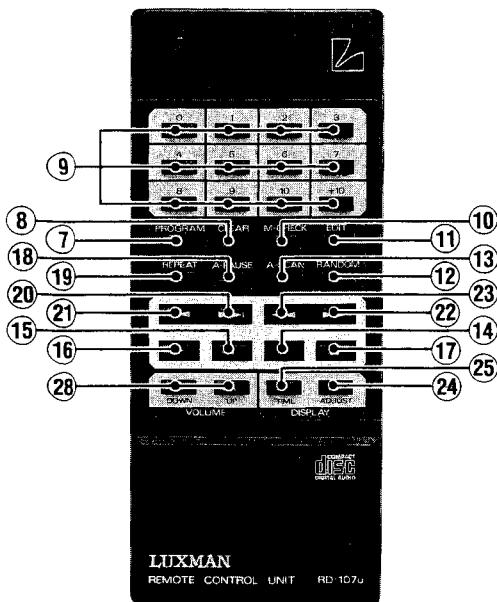
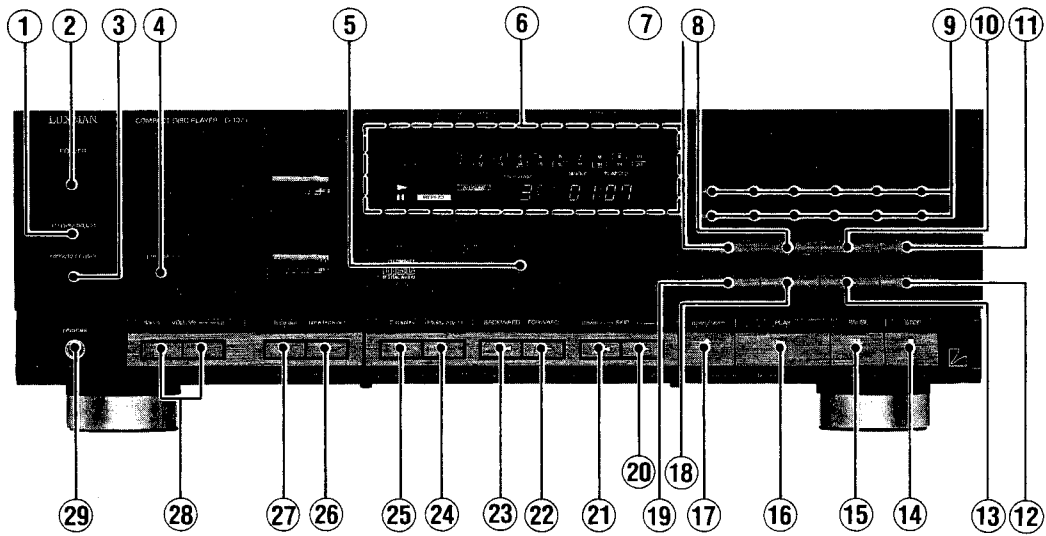

- Batteries: (Size AA) × 2
- 2 Mikrozellen (Größe AA)
- 2 piles (Dimension AA)
- 2 pilas (tamaño AA)

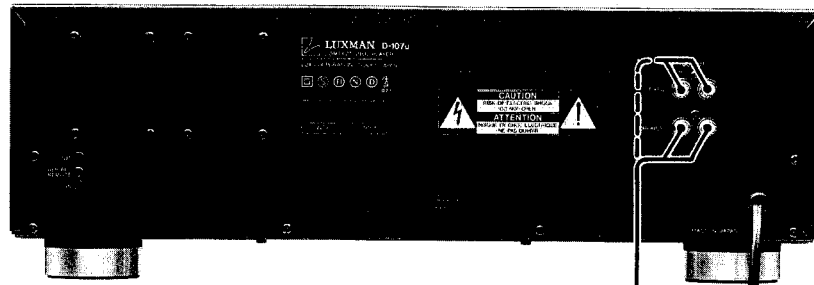

- to CD input jacks
- an die CD-Eingänge
- aux prises d'entrée CD
- a las tomas de entrada para CD

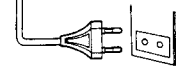

- AC Line
- Netz
- Cordon secteur
- Alimentación de red de CA

- Amplifier
- Verstärker
- Amplificateur
- Amplificador

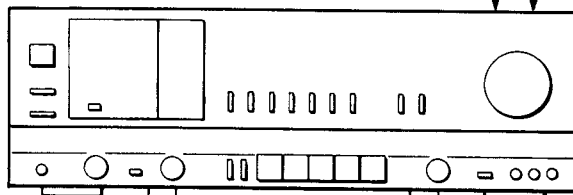

- Japanese Model
- Japanisch-Modell
- Modèle japonais
- Modelo japonés

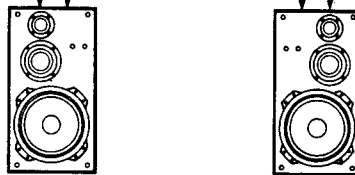

- Speaker System
- Lautsprecher
- Haut-parleurs
- Sistema de altavoces

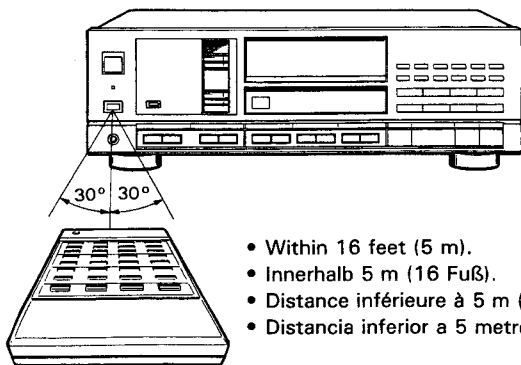

- Within 16 feet (5 m).
- Innerhalb 5 m (16 Fuß).
- Distance inférieure à 5 m (16 pieds).
- Distancia inferior a 5 metros (16 pies).

Signals/Signale/Signaux/Señales

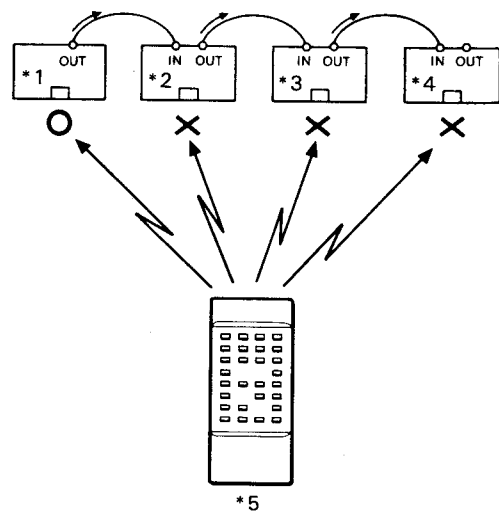

# Controls, Switches, Jacks & Terminals

## FRONT PANEL

### 1. "display adjust" indicator

This indicator lights up when the brightness of the display is set with the "display adjust" button.

### 2. POWER button

Use this button to turn the power on or off. The sound is output from the OUTPUT jacks when the vacuum tube becomes warm by turning the power on.

### 3. "remote sensor"

Receives the signal from the RD-107u remote control unit.

### 4. "pre-heating" button

Use this button to preheat the vacuum tube heater. When this button is depressed, the vacuum tube is preheated even if the power is turned off. Therefore, the sound is output from the OUTPUT jacks only 10 seconds after the power has been turned on.

### 5. Disc tray

Insert a compact disc on the disc tray. The disc tray can be opened or closed by pressing the "open/close" button. Align the compact disc with the groove.

**NOTE:** To use 8 cm (3 inch) single CD's, place them on the inner circular grooved area marked "8 cm disc" on the tray.

### 6. Display

This display indicates the preset operation mode, elapsed or remaining time, and on or off condition of the supplied functions.

### 7. "program" button

Use this button to set the unit to the program mode. During the program mode, "PROGRAM" is indicated on the display and the tracks selected with the number buttons are programmed.

### 8. "clear" button

Use this button to cancel the programmed tracks.

**NOTE:** This button works only in the stop mode.

### 9. Number buttons (0 to 10 and +10)

Use this button to perform programming of tracks, direct access, time setting for edit or time-fade-out.

### 10. "M-check" (memory check) button

Use this button to check the tracks or the order of the program.

This button works only in the stop mode. Also, this button is used to call up the track to be cleared.

### 11. "edit" button

Use this button to automatically edit the tracks on the condition that the tape length is sufficient.

Press this button, and the EDIT indicator blinks.

While it is blinking, set the length of one side of the tape with the number buttons. The tracks which can be played within the tape length of both sides are automatically edited.

### 12. "random" button

Use this button to play the tracks selected at random.

During the random play, the RANDOM indicator is turned on.

### 13. "A-scan" (auto scan) button

Use this button to play the first 10 seconds of the track one after another. The A-SCAN indicator is turned on during automatic scanning.

### 14. STOP button (■)

Use this button to stop playing. Pressing this button during play cancels the program and edit modes.

### 15. PAUSE button (||)

Use this button to stop playing momentarily. The || indicator is turned on during pause mode.

### 16. PLAY button (▶)

Use this button to start playing. The ▶ indicator is turned on during play mode.

### 17. "open/close" button (⬆)

Use this button to open or close the disc tray. When the tray is closed with a inserted disc, the DISC IN indicator is turned on. When the disc tray is opened, the all preset functions except the display adjust function are released.

**18. "A-pause" (auto pause) button**

Use this button to stop playing momentarily at the end of each track. The A-PAUSE indicator is turned on when this function is activated.

**19. "repeat" button**

Use this button to repeat play, program play, random play, edit play or auto scan. The REPEAT indicator is turned on during repeat mode.

**20. SKIP UP button (▶▶)**

Use this button to skip tracks in forward direction.

**21. SKIP DOWN button (◀◀)**

Use this button to skip tracks in backward direction.

**22. FORWARD button (▶▶)**

Use this button for fast-forwarding. The tracks are fast-forwarded while this button is pressed.

**23. BACKWARD button (◀◀)**

Use this button for fast-backwarding. The tracks are fast-backwarded while this button is pressed.

**24. DISPLAY ADJUST button**

Use this button for adjust the display brightness. Four steps of brightness and turning-off are selectable. During adjusting, the "display adjust" indicator blinks.

**25. "T-display" button**

Each push of this button selects one of 4 disc timing displays as follows:

- SINGLE ELAPSED: To indicate the elapsed play time of a track
- TOTAL ELAPSED: To indicate the elapsed play time of the whole disc
- SINGLE REMAIN: To indicate the remaining play time of a track
- TOTAL REMAIN: To indicate the remaining play time of the whole disc

**26. TIME FADE-OUT button**

Use this button to fade-out the volume from the VARIABLE OUTPUT or "phones" jacks at the time preset with the number buttons. When the fade-out operation is completed, the unit is set to pause mode and the volume automatically increases to the original level.

**27. FADE-OUT button**

Use this button to fade-out the volume from the VARIABLE OUTPUT jacks. When the fade-out operation is completed, the unit is set to pause mode and the volume automatically increases to the original level.

**28. VOLUME "up/down" buttons (◁ ▷)**

Use these buttons to adjust the volume output from the VARIABLE OUTPUT or "phones" jacks. During volume adjustment, the output level (-00 dB to -70 dB, --- dB) is indicated on the display. Normally set it to -00 dB and adjust it if necessary.

**29. "phones" jack**

For connecting the stereo phone plug of head-phones. The volume can be controlled with the VOLUME buttons. Also fade-out and time fade-out can be activated.

**REAR PANEL****30. SERIAL REMOTE IN/OUT jacks**

Connect this jack with the optional remote control unit to perform system remote control.

**NOTE:** Turn the power off before connecting these jacks.

**31. VARIABLE OUTPUT R/L jacks**

For connection to the CD inputs of any amplifier. The output level from these jacks can be controlled with the VOLUME button. Also, fade-out and time fade-out can be activated.

**32. FIXED OUTPUT R/L jacks**

For connection to the CD inputs of any amplifier. The output level is 2 volts fixed, referenced to 0 dB recording level.

**33. Power cord**

Insert the AC plug of the D-107u into any wall outlet.

## Connection Guidelines

### BEFORE MAKING CONNECTIONS

It is always wise to ensure that all AC power cords of the various components that you are interconnecting are unplugged from the wall outlets during the hook-up process. This will prevent any inadvertent damage to your speakers or amplifier from incorrect control settings or connections.

### CONNECTION OF THE OUTPUT JACKS

■ Connect either VARIABLE or FIXED OUTPUT jacks to the CD input jacks of the amplifier with the supplied phono plug cord.

**NOTE:** To adjust the output level or activate fade-out or time fade-out, connect the VARIABLE jacks.

In addition, audio jacks on Luxman equipment, including the D-107u, have red centers for right channel and white for left channel.

When making connections, follow the connection diagram (See page 5.), referring also to the descriptions for items 30 through 33 on page 7.

### CONNECTION OF THE SERIAL REMOTE IN/OUT JACKS

- "Daisy Chain" Serial Connections (See page 5).
    - O: Remote Operation Possible
    - X: Remote Operation Not possible
    - \*1: Remote Controller (F-105, U-100, etc.)
    - \*2: D-107u
    - \*3: Tape Deck (Future Product)
    - \*4: Tuner
    - \*5: RF-105, etc.
- Components \*2,3 and 4 can be connected in any order.

**NOTE:** Turn the power off before connecting these jacks.

### CONNECTION OF THE AC POWER CORD

Insert the AC plug of the D-107u into any wall outlet.

**CAUTION:** NO RELATION TO THE POWER BUTTON.  
AN APPARATUS FALLS INTO CURRENT-CARRYING CONDITION, AS SOON AS THE AC POWER CORD IS CONNECTED.

## Operation Guidelines

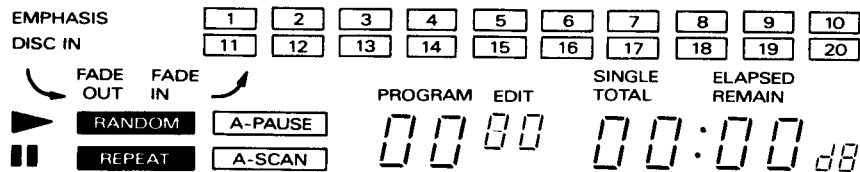

### INITIAL SET-UP

- Turn the power on.
- Play is delayed until the vacuum tube becomes warm (approximately 30 seconds when the preheating is off, or approximately 10 seconds when it is on).
- Press the "open/close" button and set a compact disc on the disc tray, label side up.

**NOTE:** To use 8 cm (3 inch) single CD's, plade them on the inner circular grooved area marked "8 cm disc" on the tray.

- Press the "open/close" button to close the disc tray.
- If one of the ►, ||, number or "A-scan" buttons is pressed when the disc tray is open, the disc tray is closed without pressing the "open/close" button and the unit performs the operation of the button pressed.
- When the compact disc is inserted, the DISC IN, track number and total play time of the disc are indicated on the display.
- Set the volume control of the amplifier to minimum and adjust it after play has started.

### PLAY

- After the compact disc is loaded, press the PLAY button.
- The ► indicator is turned on and play starts from the first track.
- Play stops with completion of the last track, when no REPEAT indicator is turned on.

### PAUSE

- Press the PAUSE button.
- The || indicator is turned on and play pauses when the PAUSE button is pressed.
- To resume play, press the PAUSE or PLAY button. The pause mode is cancelled and play is resumed from the previous position.

### STOP

- Press the STOP button.

**NOTE:** Pressing of the STOP button during stop mode cancels the program or edit mode.

### TO SKIP FORWARD OR BACKWARD

- To skip forward:
  - Each pressing of the SKIP UP button skips tracks in forward direction one by one. Keep the button pressed to skip all tracks after the one indicated on the display. Keep the FORWARD button pressed for fastforwarding.
- To skip backward:
  - Pressing of the SKIP DOWN button during play repeats the current track from the beginning.
  - Each pressing of this button between tracks skips tracks in backward direction one by one. Keep the button pressed to skip all tracks before the one indicated on the display. Keep the BACKWARD button pressed for fastbackwarding.

### DIRECT ACCESS

Play can be started from the selected track with the number buttons.

- Select the desired track number with the number buttons during stop or play mode.
- If the track is selected during pause mode, the unit is set to pause mode at the beginning of the selected track.
- The direct access can not be activated in program, random play, edit and time fade-out modes.
- The selected track is called up and played.

### [To select a track]

For track number 1 to 10, press the number buttons of the track number. For track number 11 or higher, first press +10 for the 10 unit and 0 to 10 for units from 1 to 10.

- If one of the ►, II, ◀◀ or ▶▶ buttons is pressed after selecting the 10 unit with the +10 button, the operation button functions in the same way as when the 0 button is pressed.
- Only track numbers existing on the compact disc can be selected.

**NOTE:** Direct access will be cancelled if a number button other than "+10", the Play button, or the Pause button is not pressed within 4 seconds after pressing "+10".

The "+10" button will not operate with discs containing 10 or fewer tracks.

**Example:** To directly access the 17th track

- Press +10 and 7 in this order.

**Example:** To directly access the 20th track

- Press +10 and 10, or +10 twice and 0 in this order.

### RANDOM PLAY

If desired, activating this function will allow the computer in the unit to select tracks, in a completely random manner, for playback. While the selection is random, it does not repeat any given track, rather, it plays each randomly selected track once, shutting off automatically after all tracks are played. If the REPEAT function is also selected, then the unit will continuously replay all tracks but in a completely different order each time.

- Press the RANDOM button. The RANDOM indicator is turned on.

**NOTE:** When the PROGRAM or EDIT indicator is lit or blinking, the program or edit mode is released by pressing the RANDOM button.

- Press the PLAY button
- Press the RANDOM button during play, and random play is started.

**NOTE:** During the random play mode, undesired tracks that you do not want included in the random selection, can be individually deleted. Simply press the number button of the track(s) you wish to delete. The deleted track number(s) will disappear from the upper part of the display.

- The unit stops with completion of the last track, when REPEAT indicator is not turned on.

### AUTO SCAN

The first 10 seconds of each track on the compact disc can be played in numerical order.

- Press the "A-scan" button. The A-SCAN indicator is turned on and auto scanning is started.
- To cancel auto scan mode, press one of the ◀◀, ▶▶, ◀◀, ▶▶, II, ■ or number buttons, or the "A-scan" button again.
- The unit stops with completion of the last track, when no REPEAT indicator is turned on.
- Auto scan can be activated with random or program play.

### AUTO PAUSE

The unit can be automatically set to enter the pause mode at the end of any currently playing track.

- Press the "A-pause" button. The A-PAUSE indicator is turned on.
- While the A-PAUSE indicator is turned on, pressing one of the ◀◀, ▶▶ or number buttons sets the unit to pause mode at the beginning of the track.
- To cancel auto pause mode, press the "A-pause" button. The A-PAUSE indicator is turned off.

### PROGRAM PLAY

Only desired tracks can be selected and played.

- Press the "program" button in stop mode. The PROGRAM indicator is turned on. Select the desired tracks with the number buttons in order to program.

**NOTE:** When the RANDOM or EDIT indicator is lit or blinking, pressing the "program" button cancels the random or edit mode.

- A total of 32 tracks can be programmed. If you try to program more tracks, the FULL indicator is turned on for about 4 seconds and no more programs are accepted.
- When the ► indicator is blinking, press the PLAY button and program play is started.
- The unit stops with completion of the last track, when no REPEAT indicator is turned on.

**NOTE:** If the Repeat button has been pressed, REPEAT indicator will be displayed and the frames around the track numbers will reappear when the sequence repeats. Only those tracks programmed will be repeated.

### TO CHECK THE PROGRAMS

The programmed track numbers and their order can be checked.

- Stop program play and press the "M-check" button.

- The track numbers and their order are indicated by each pressing of the "M-check" button.

**NOTE:** While the program play is stopped, keep the "M-check" button pressed. The auto memory check mode is activated, and the track numbers and their order are shown automatically. When all tracks in the program is checked, auto memory check mode is released.

### TO CLEAR THE PROGRAMS

The tracks in the program can be erased.

- Stop program play and press the "clear" button. Each pressing of the "clear" button clears one track at a time from the last programmed track.
- To clear a track, call up and indicate the track number with the "M-check" button and press the "clear" button.
- To clear all tracks, press the STOP button twice. The PROGRAM indicator is turned off.

### REPEAT

Play, program play, random play and auto scan can be repeated.

- Press the "repeat" button. The REPEAT indicator is turned on.
- To cancel the repeat function, press the "repeat" button again. The REPEAT indicator is turned off.

### TO CHANGE THE TIME INDICATION

The elapsed or remaining time can be displayed.

- Press the "T-display" button to select the time read-out desired.

**SINGLE ELAPSED:** To indicate the elapsed play time of a track

**TOTAL ELAPSED:** To indicate the elapsed play time of the whole disc

**SINGLE REMAIN:** To indicate the remaining play time of a track

**TOTAL REMAIN:** To indicate the remaining play time of the whole disc

- During random play, TOTAL ELAPSED and TOTAL REMAIN times can not be indicated and "-- --" appears. This is not a malfunction.
- When the VOLUME button is pressed, the time read-out is turned off and the volume level is indicated.
- During program operation, the total programmed play time is displayed.

### EDIT PLAY

This feature is specifically intended to select and divide CD tracks, on the basis of timing, to fit the recording time on the A and B sides of any given tape cassette type. For instance, the EDIT function would be set to 30 minutes to fit both sides of a C-60 cassette. It divides a group of whole tracks, as closely as is possible, into two 30 minute sections. When the first side is recorded, the D-107u automatically stops so that the tape can be turned over in the cassette recorder. The 2nd half of the grouped tracks are then selected and the system restarted to record the 2nd side. Proceed as follows.

- Set the unit to stop mode and press the "edit" button. The EDIT indicator blinks showing that the edit function is ready.

**NOTE:** When the RANDOM or PROGRAM indicator is turned on, pressing the "edit" button cancels the random or program mode.

- Set the editing time of one side of the tape with the number buttons. (If it is a C-90, set the time to 45 minutes.)

**NOTE:** By setting the time of only one side, the tracks are edited for both sides.

- When the edit time is set, the tracks to be recorded on both sides of the tape are automatically programmed. The EDIT indicator lights up.

**NOTE:** Some tracks may be excluded or some part of the tape may be blank due to difference between the track length and edit time.

- To check the edited content, press the "edit" button for each side. The actual tracks selected, along with their total playing (recording) time, will be shown in the display.
- Play can be started from the track indicated with the "edit" button.
- You are now ready to begin recording. With the set of tracks selected for side A, press the Play button and at the same time place the cassette deck in record mode on side A. When side A finishes, the D-107u will go into STOP mode.
- Now press the Edit button to select the 2nd set of tracks intended for side B. Flip the cassette over in the cassette deck and initiate the play and record process as before.

#### [How to set the edit time]



When the edit time is within 10 minutes, press 1 to 10 of the number button. When it is more than 10 minutes, first press +10 for the 10 unit and 0 to 10 for units from 1 to 10.



## FADE-OUT

This feature works through the motor driven level control and provides a smooth, computer controlled, precision fade out action. It is specially useful when making tape recordings from CD's. It is much more professional than manual fades and can be initiated at any playback point on a musical selection. It is fed to the VARIABLE OUTPUT jacks on the rear panel, and to the "phones" jacks.

**NOTE:** The fade-out function does not work with the FIXED OUTPUT jacks.

- Press the FADE-OUT button during play.
- The  FADE OUT indicator blinks and the volume level will fade-out. When the volume level becomes minimum, the unit is set to pause mode.
- In pause mode, the FADE IN  indicator blinks and the volume level gradually increases to the original level.
- The time needed for fade-out depends on the volume level. The higher the volume level is set, the longer time it takes.

## TIME FADE-OUT

The time preceding the actual fade out (for the VARIABLE OUTPUT jacks and the "phones" jacks) can also be set.

**NOTE:** The time fade-out function does not work with the FIXED OUTPUT jacks.

**NOTE:** Time fade-out does not function in random play mode, or when higher than 32nd track in the disc is programmed.

- Press the TIME FADE-OUT button.
- Set the fade-out time with the number buttons.

**NOTE:** Time fade-out function does not work, if the preset time is longer than total elapsed time or total programmed time.

- Press the PLAY button. The fade-out is activated a few seconds before the preset time. When fade-out is completed at the preset time, the unit is set to pause mode.

**NOTE:** To view the countdown time to the fade out point, set the T-Display to the "Total Remain" position.



- In pause mode, the FADE IN  indicator blinks and the volume level gradually increases to the original level.
- The time needed for fade-out depends on the volume level. The higher the volume is set, the longer time it takes.

## [How to set the time]

To activate fade-out within 10 minutes, press 1 to 10 of the number buttons. To activate it after 10 minutes or more, first press the +10 for the 10 unit and 0 to 10 for units from 1 to 10.

## VOLUME CONTROL

The volume level from the VARIABLE OUTPUT and "phones" jacks can be adjusted.

- Press the VOLUME "up" button [  ] to increase the volume (maximum -00 dB), or "down" [  ] to decrease it (minimum -70 dB, --- dB indicates that no sound is produced).
- Usually set the volume at maximum (-00 dB), and adjust it if necessary.

## TIME PLAY

Play can be started at the desired time with the timer function.

- Connect the power plug of the unit to be timer activated to the AC outlet of the timer.
- Turn the power on and insert the compact disc.

**NOTE:** This unit keeps the memory of program, edit or random play for about 3 days, even if the power is turned off.

Therefore, the preset program, edit or random play starts when the power is turned on. When no program, edit or random play is preset, the play starts from the first track of the compact disc.

- Set the start or stop time with the timer. Also, perform necessary operations on the units to be timer activated.
- Set the power buttons of the units to be timer activated to on-position.
- When the power is turned on with the timer and the vacuum tube becomes warm, activated unit is set to play mode.

## REMOTE OPERATIONS

For reliable operation, use the hand-held remote within the basic dimensional area (See on page 5.). To operate, select and press the individual buttons in the same manner as that described for the front panel buttons, referring to page 6 and 7.

# Care & Maintenance

## BATTERY REPLACEMENT

1. Open the battery compartment cover on the rear of the remote control unit. The cover should open easily if you press on it with your thumb.
2. Place two "AA" size dry batteries in the battery compartment in accordance with the diagram in the compartment, then replace the cover.

Incorrect use of batteries may lead to leakage or rupture. Always be sure to follow these guidelines:

- A. Always insert batteries into the battery compartment correctly matching the positive (+) and negative (-) polarities as shown in the diagram inside the compartment.
- B. Never mix new and used batteries together.
- C. Both rechargeable and non-rechargeable batteries are available. Be sure to use your batteries in accordance with the instructions provided on the cells.

## PRECAUTIONS

Condensation may occur inside the set if it is brought into a warm room from the cold or if a cold room is heated quickly. If this happens, drops of water may form on the pick-up, scattering the laser beam and hampering operation.

The extent of condensation depends on various conditions, but if condensation should occur, remove the disc then turn on the power and wait at least one hour before using the unit.

## PROPER CARE OF COMPACT DISC

Improper handling of your disc will shorten its life. Hold the disc so that you will not leave fingerprints on the surface of the disc.

When your disc is not in use, place it in the case and store it in a place away from the sun, high temperature, humidity, and dust. Should your disc require cleaning, use a clean soft cloth only. Do not use oil or chemically treated cloths.

## CLEANING

The durable finish of the knobs and heavy aluminum front panel will last indefinitely with proper care and cleaning. Never use scouring pads, steel wool, scouring powders, or harsh chemical agents, such as lye solution. These will mar the finish. Clean with a soft, lintfree cloth or cotton swab slightly dampened with a mild solution of detergent and water.

## REPACKING FOR SHIPMENT

Should it become necessary to ship your D-107u for any reason, use the original packing materials. If these are no longer available, be sure that adequate materials, at least equivalent to the original, are used.

## REPAIRS

Only the most competent and qualified service technicians should be allowed to service the D-107u. The Luxman company and its factory-trained warranty station personnel have the knowledge and special equipment needed for repair and calibration of this precision instrument.

In the event of difficulty, call the Luxman Authorized Service Station nearest your home or business. In many cases, the dealer where you purchased your Luxman unit will be equipped to provide service.

# Adjustment Procedures

## 1. Compact Disc Section

### (1) Connections

#### (1) 接続図

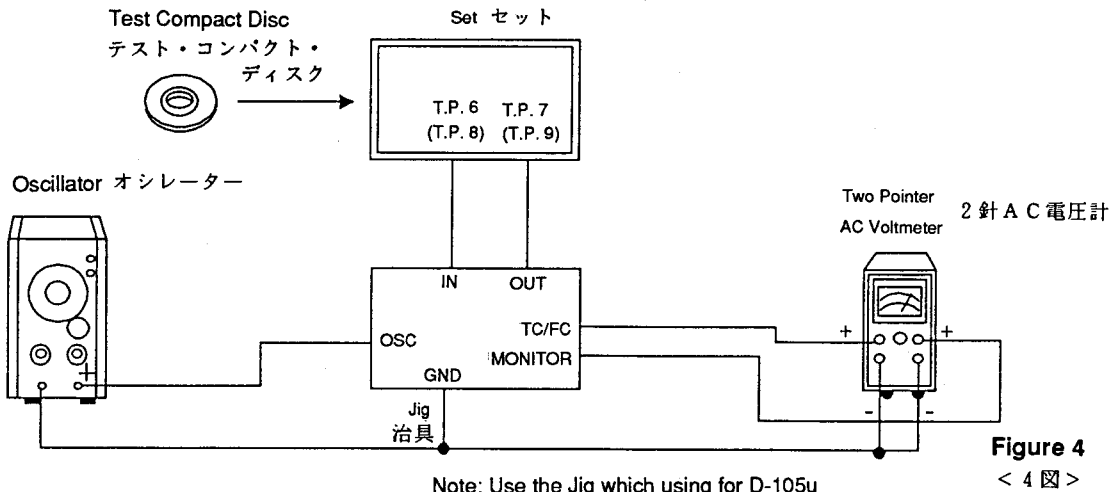
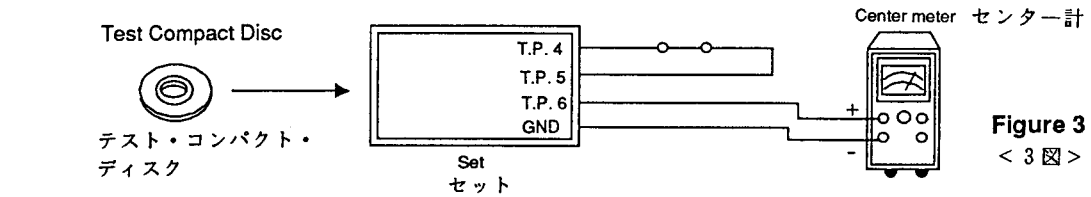
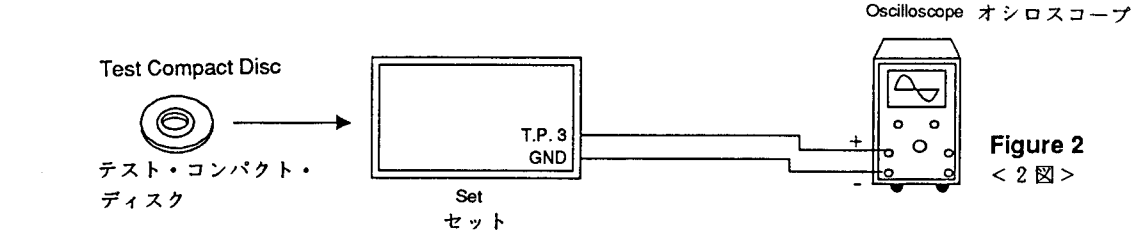
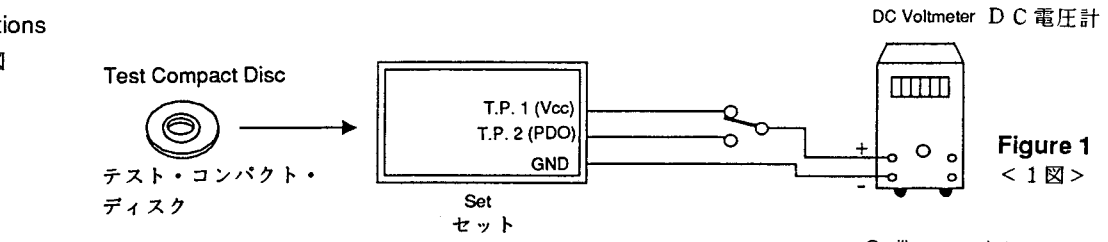

Note: Use the Jig which using for D-105u  
注：D-105uに使用した治具を使用する

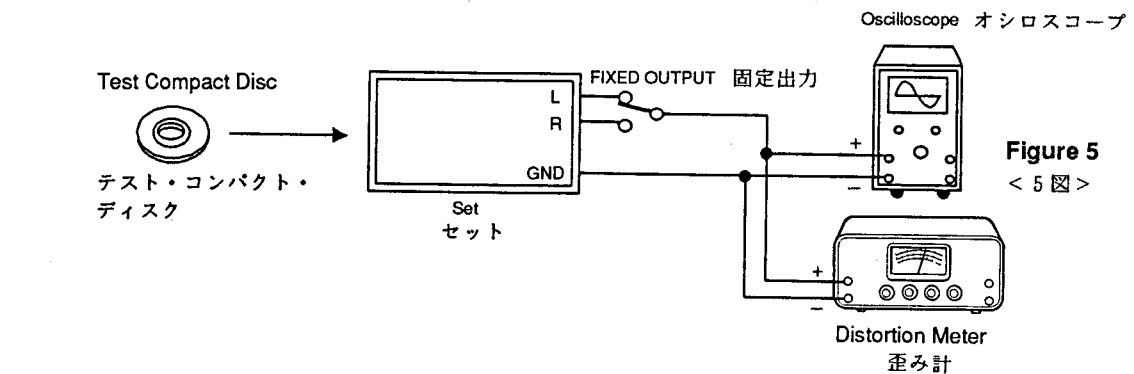

(2) Control Settings

Power Switch ..... ON  
 Play Switch ..... ON  
 Others Switch ..... OFF

(3) Test CD

Tracking Error Balance Adjustment ..... SONY YEDS-18 (No7)  
 A-BEX TCD-782 (No8)  
 Level Linearity Adjustment ..... A-BEX TCD 781 (No26)  
 Others ..... SONY YEDS-18 (No2)  
 A-BEX TCD-782 (No2)

(4) Adjustment Procedures

Step	Description	Connections	Oscillator	Test Point	Adjustment
1	VCO Adjustment	Figure 1	—	T.P.1 T.P.2	Take measurement of the voltage at the T.P.1. Then adjust VR202 so that the output voltage at the T.P.2 becomes 1/2 ±10mV of the voltage at the T.P.1.
2	Focus Bias Adjustment	Figure 2	—	T.P.3	Adjust VR201 so that the T.P.3 (Eye pattern) signal is at its maximum, with a favorable Eye pattern as shown in Figure 6.
3	Tracking Error Balance Adjustment	Figure 3	—	T.P.4 T.P.5 T.P.6	After short circuiting between T.P.4 and T.P.5, turn VR204 fully counterclockwise. When the center meter is connected to the unit, the meter pointer will deflect between "a" and "b" as shown in Figure 7. Adjust VR203 until minimum deflection of the center meter shows "0". In this case, minimum deflection shows "0" stands for that "a". After the adjustment set VR204 to its center position.
4	Tracking Gain Adjustment	Figure 4	1kHz 100mV	T.P.6 T.P.7	Adjust VR204 so that both arms of the voltmeter come at the same position.
5	Focus Gain Adjustment	Figure 4	1kHz 100mV	T.P.8 T.P.9	Adjust VR205 so that both arms of the voltmeter come at the same position.
6	Level Linearity Adjustment	Figure 5	—	FIXOUT L(R)	Adjust the volume control (VR101) so that the output voltage at FIXOUT becomes 2V. (This point will be 0dB and used as the base.) Then adjust VR207 (VR208) so that the output voltage at FIXOUT becomes 70dB below the base and distortion becomes the minimum.

(2) スイッチ類のセット位置

電源スイッチ..... ON  
 プレイスイッチ..... ON  
 その他のスイッチ..... OFF

(3) テストCD

トラッキング・エラー・バランス調整..... SONY YEDS-18 (No7)  
 A-BEX TCD-782 (No8)  
 レベル直線性調整..... A-BEX TCD-781 (No26)  
 その他..... SONY YEDS-18 (No2)  
 A-BEX TCD-782 (No2)

(4) 調整方法

順序	調整項目	接続図	オシレーター	テストポイント	調整方法
1	VCO調整	1図	—	T.P.1 T.P.2	T.P.1の電圧を測定します。次にT.P.2の出力電圧がT.P.1の電圧の1/2±10mVになるようにVR202で調整します。
2	フォーカス バイアス調整	2図	—	T.P.3	T.P.3 (アイ・パターン) 信号が最大になるようにVR201で調整します。望ましいアイ・パターンは6図に示しています。
3	トラッキングエラー バランス調整	3図	—	T.P.4 T.P.5 T.P.6	T.P.4とT.P.5の間をショートした後、VR204を反時計方向にしぼりきります。センター計を装置に接続したとき、メータの針は7図に示すように、"a"と"b"の間で歪みます。センター計の最小歪みが"0"を示すまでVR203で調整します。この手順では最小歪みが"0"を示すということは、"a"を表します。調整後、VR204を中央付近に戻します。
4	トラッキング ゲイン調整	4図	1kHz 100mV	T.P.6 T.P.7	電圧計の2つの針が重なるようにVR204で調整します。
5	フォーカス ゲイン調整	4図	1kHz 100mV	T.P.8 T.P.9	電圧計の2つの針が重なるようにVR205で調整します。
6	レベル直線性調整	5図	—	FIXOUT L(R)	FIXOUTの出力が2Vになる様ボリュームコントロール (VR101)で調整します。(この時0dBとする→基準) 次にFIXOUTの出力が基準に対し-70dBかつ歪率が最小になる様VR207 (VR208)を調整します。

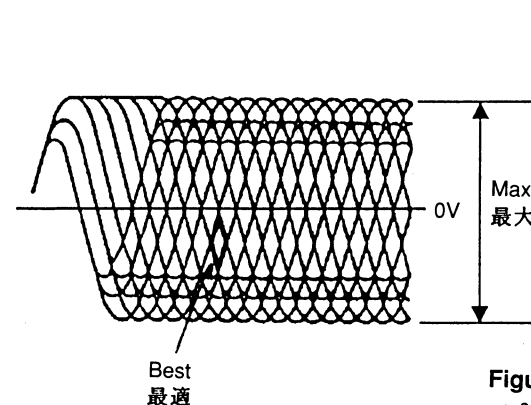

Figure 6  
 < 6 図 >

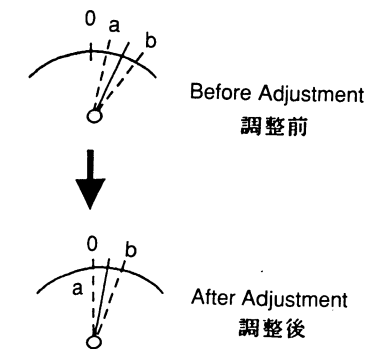
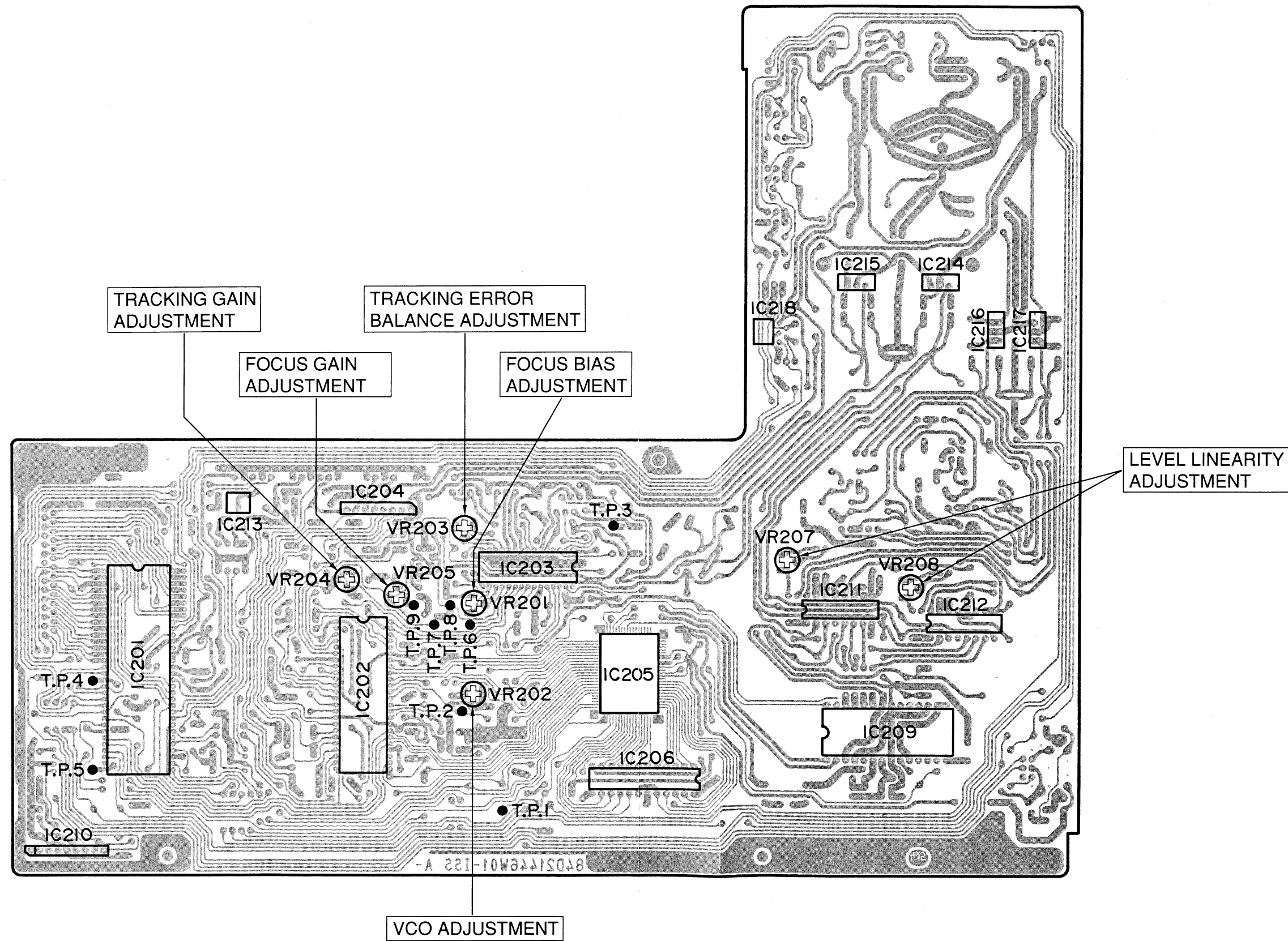
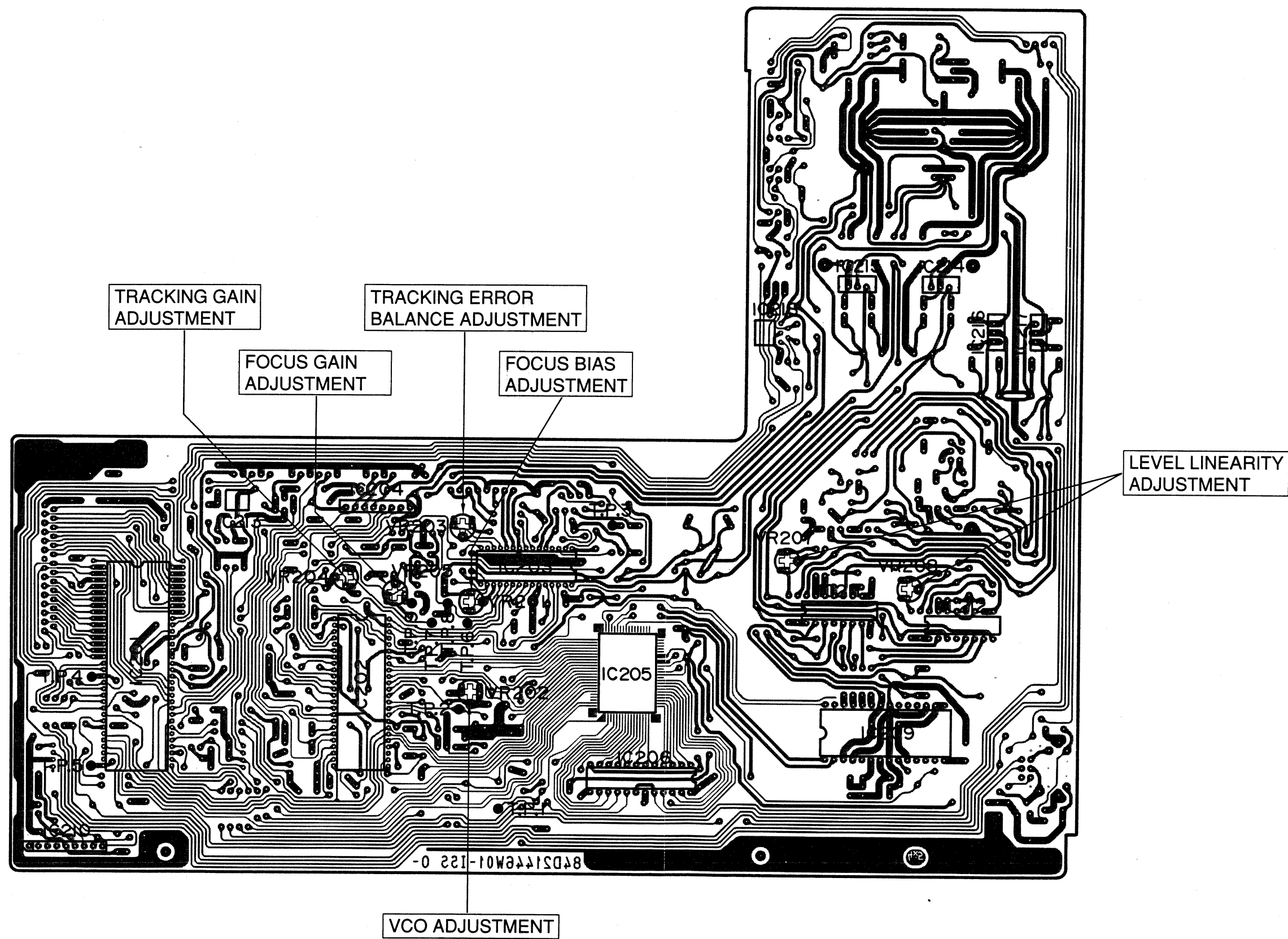

Figure 7  
 < 7 図 >

### Adjustment Locations (AD)



### Adjustment Locations (JA)



# Block Diagram

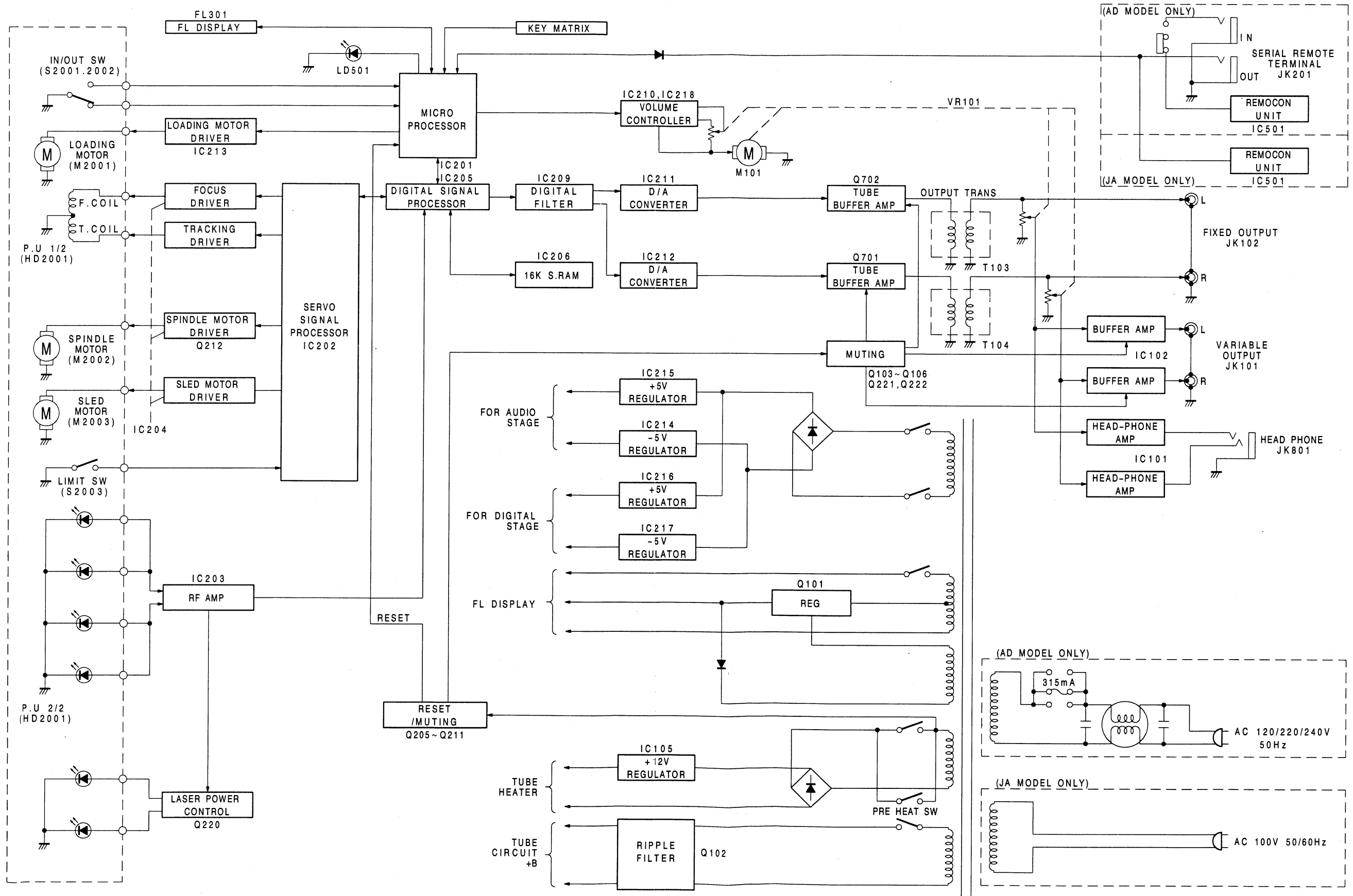

# Schematic Diagram (1/3) <AD model>

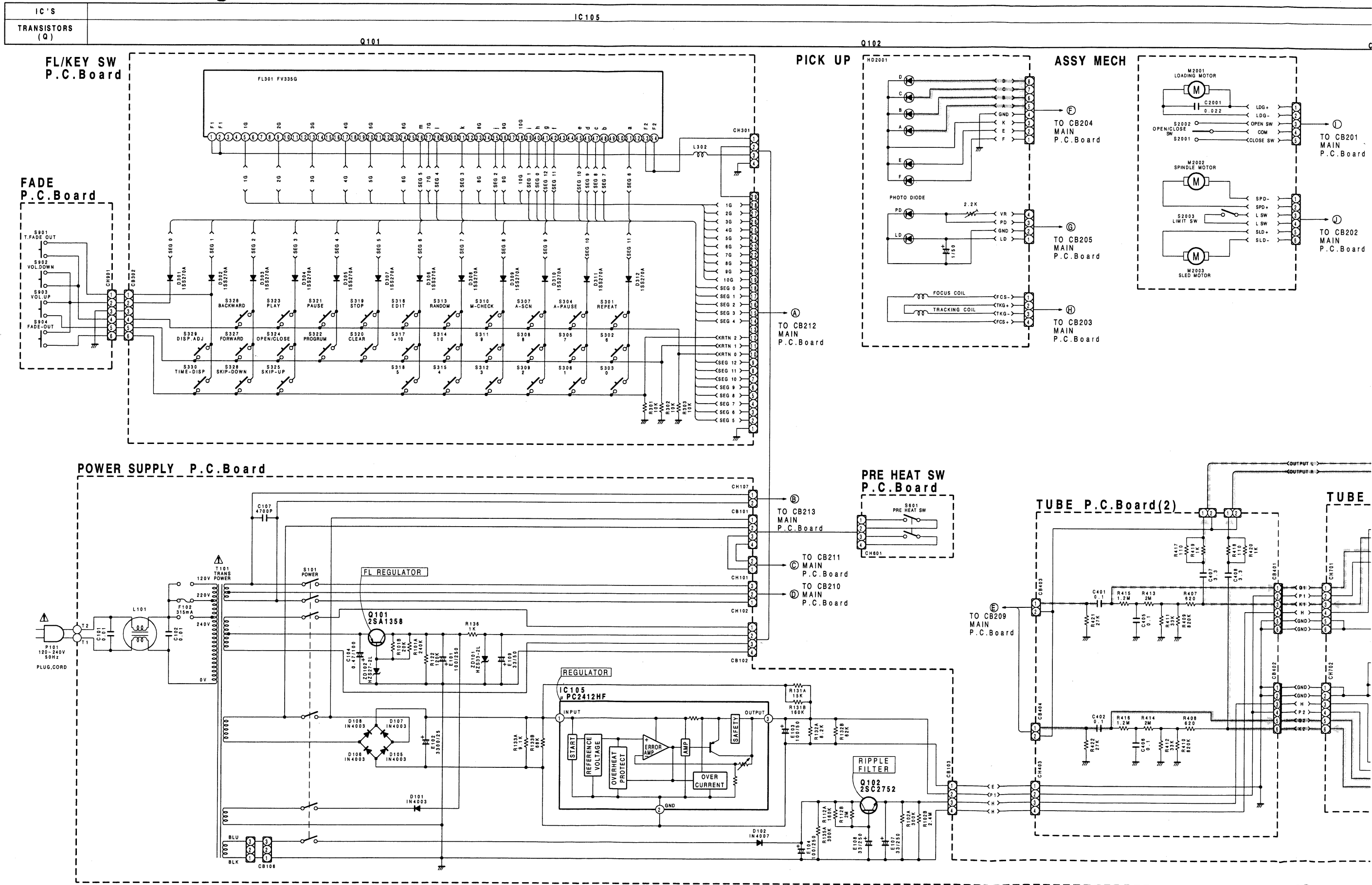

A | B | C | D | E | F | G | H



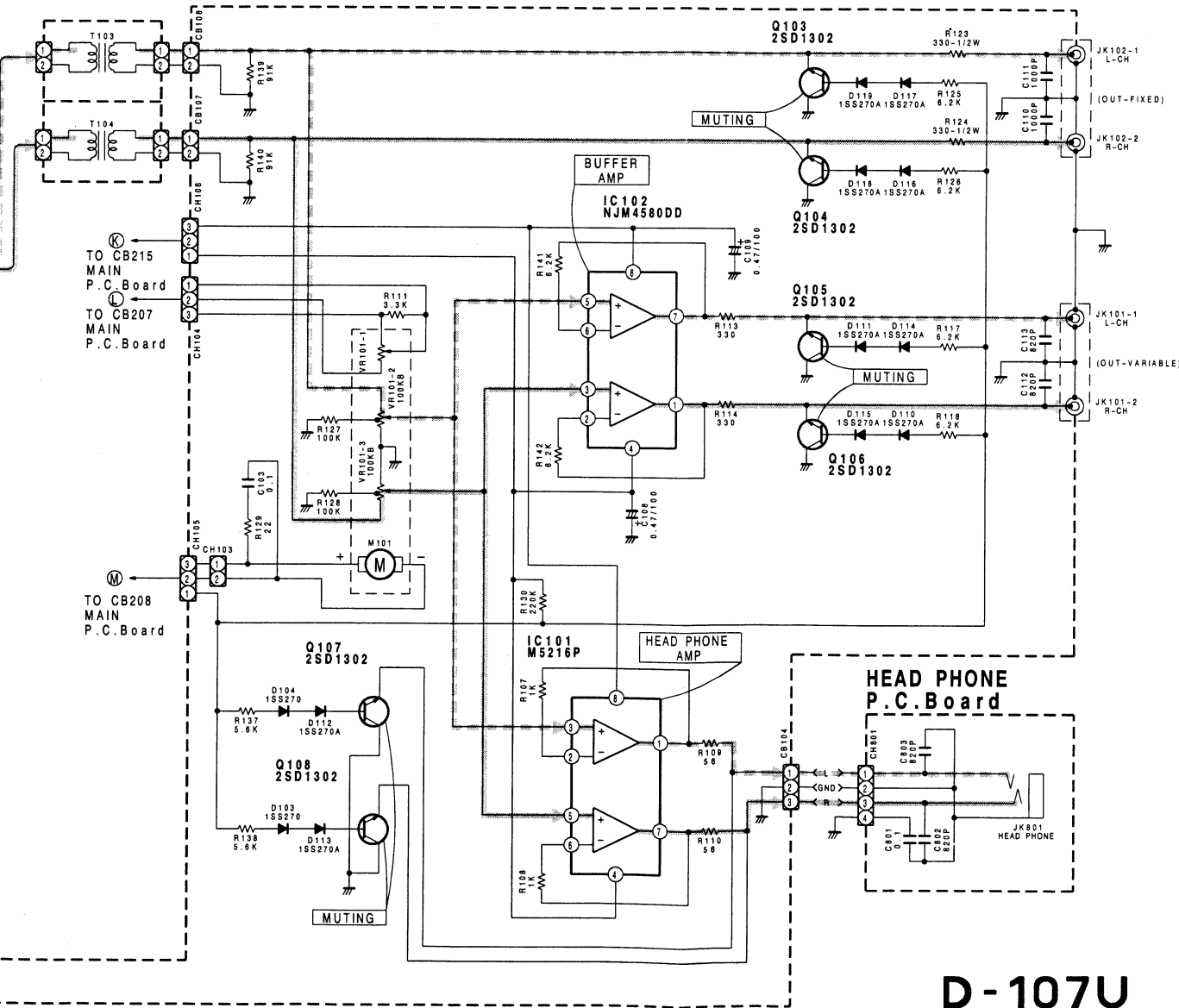
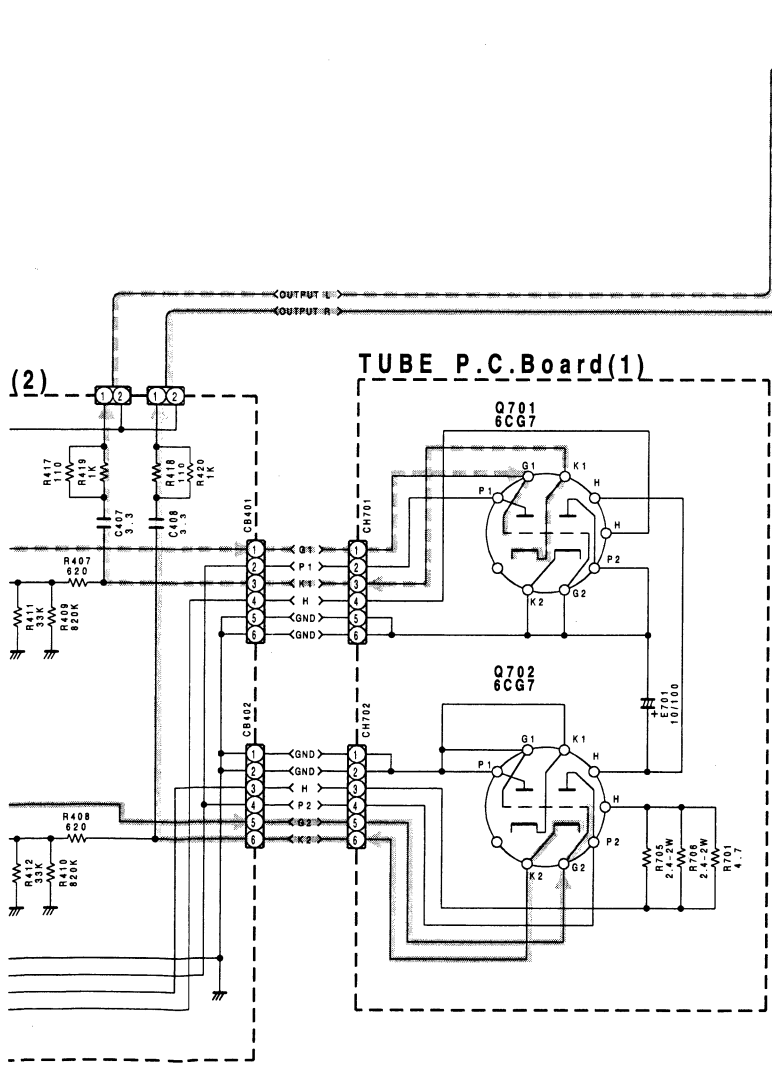
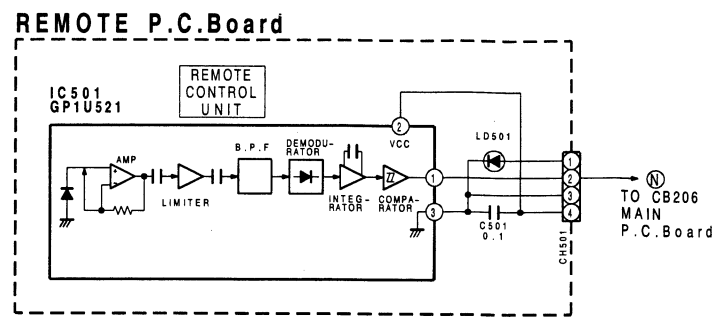
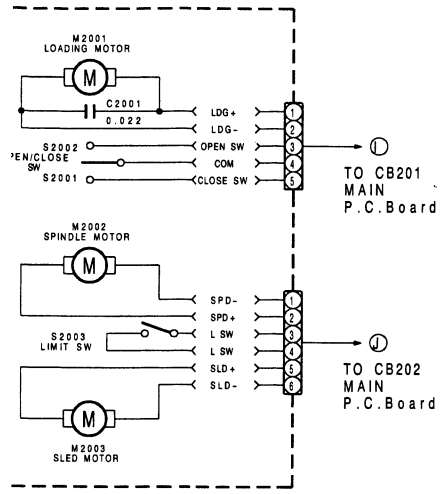
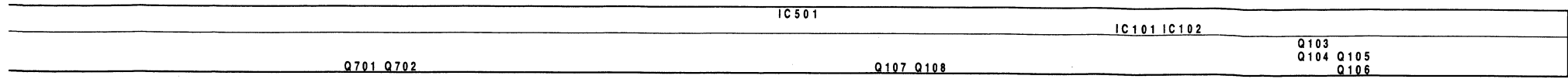

D-107U

H | I | J | K | L | M | N | O

# Schematic Diagram (1/3) <JA model>

IC'S	IC105
TRANSISTORS (Q)	Q101, Q102

1

2

3

4

5

## FL/KEY SW P.C.Board

## FADE P.C.Board

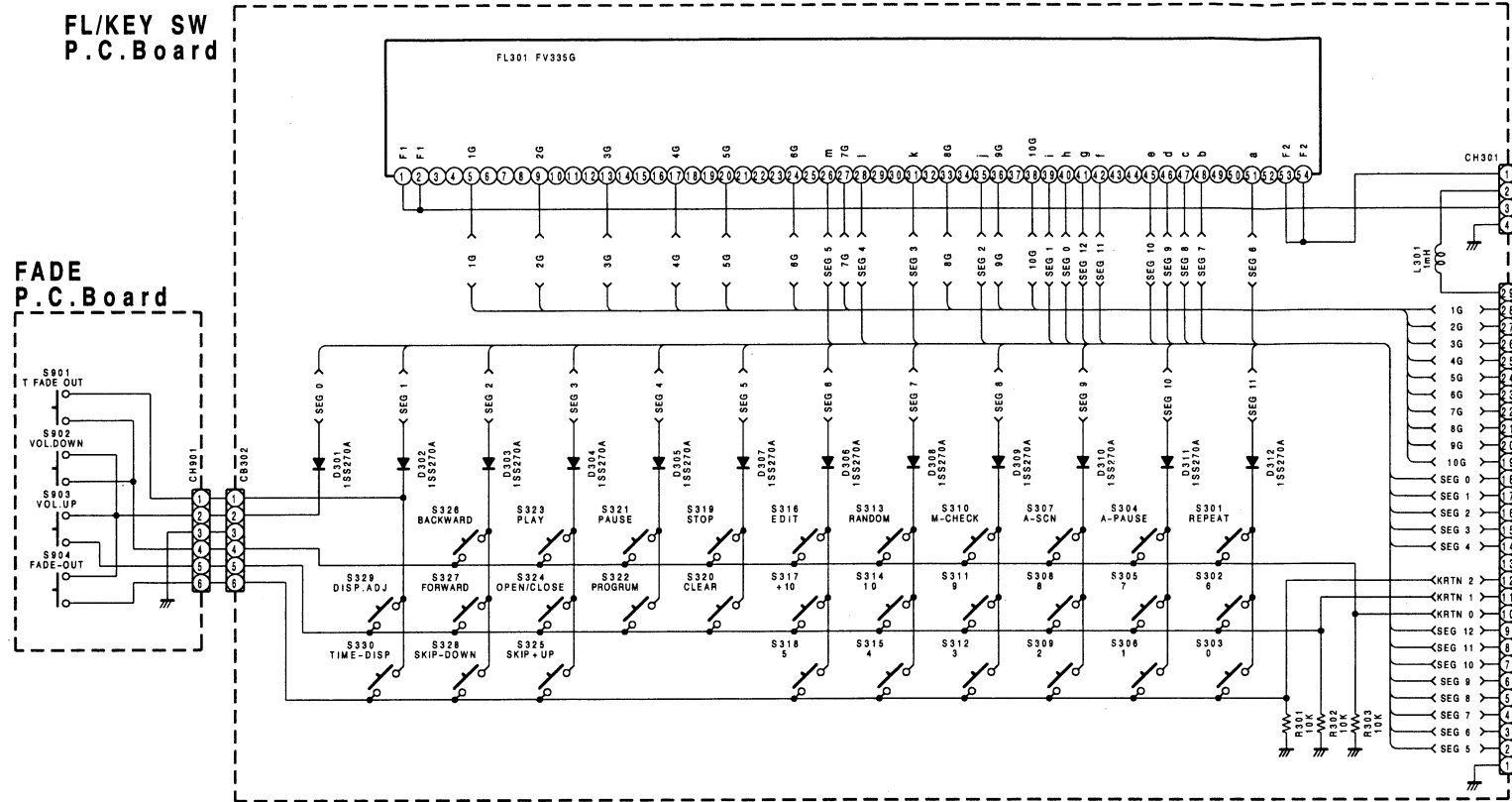

## PICK UP

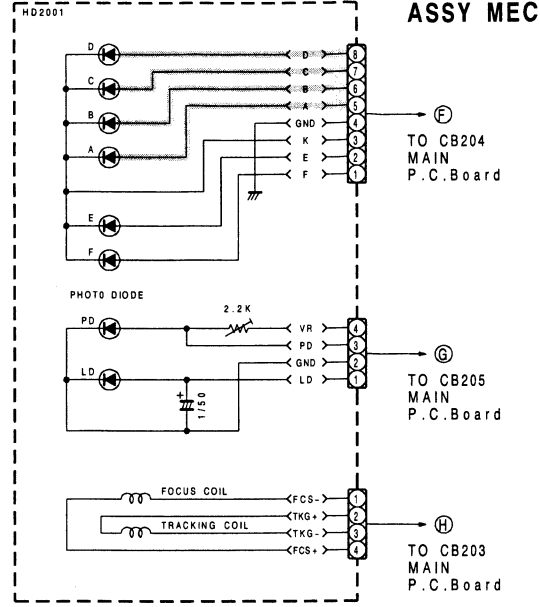

## ASSY MECH

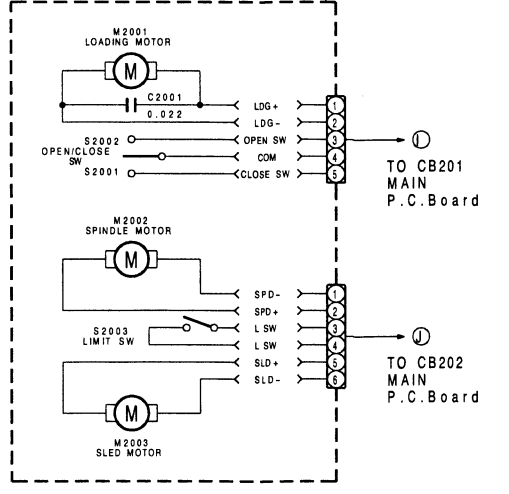

## POWER SUPPLY P.C.Board

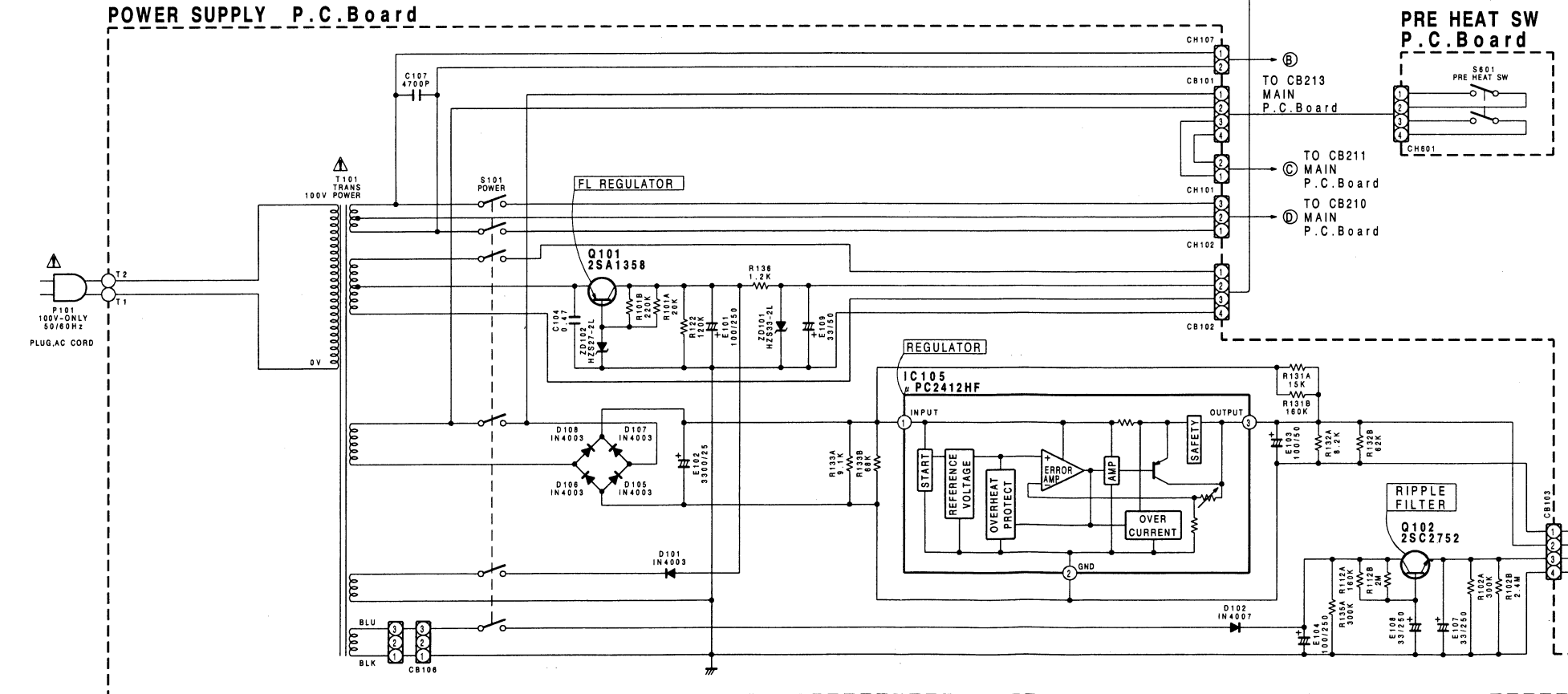

## PRE HEAT SW P.C.Board

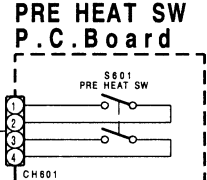

## TUBE P.C.Board(2)

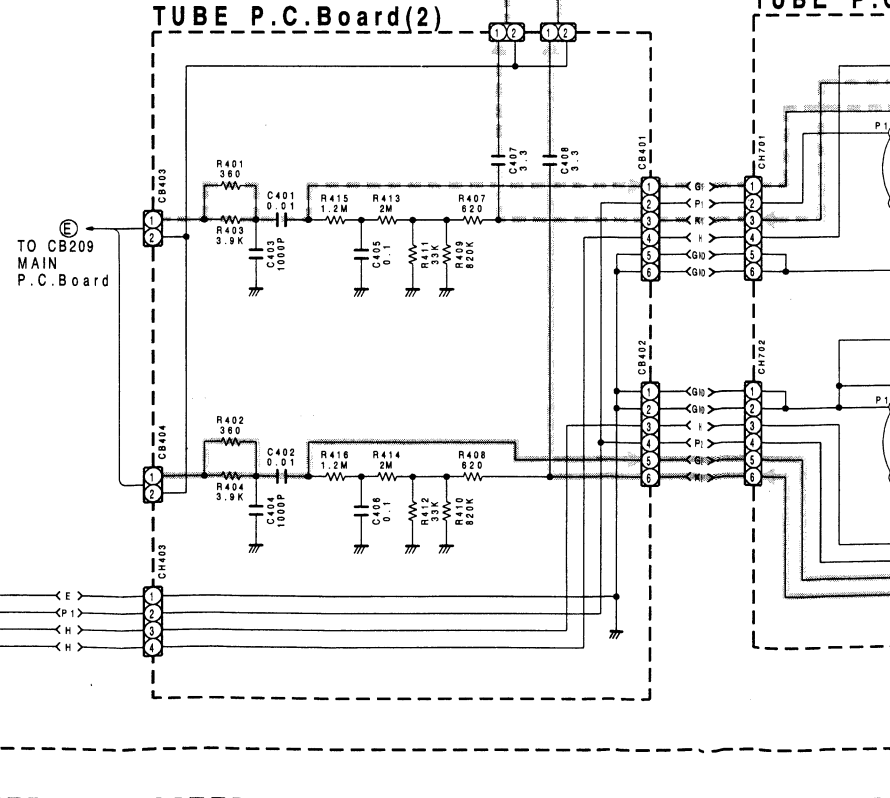

A | B | C | D | E | F | G | H

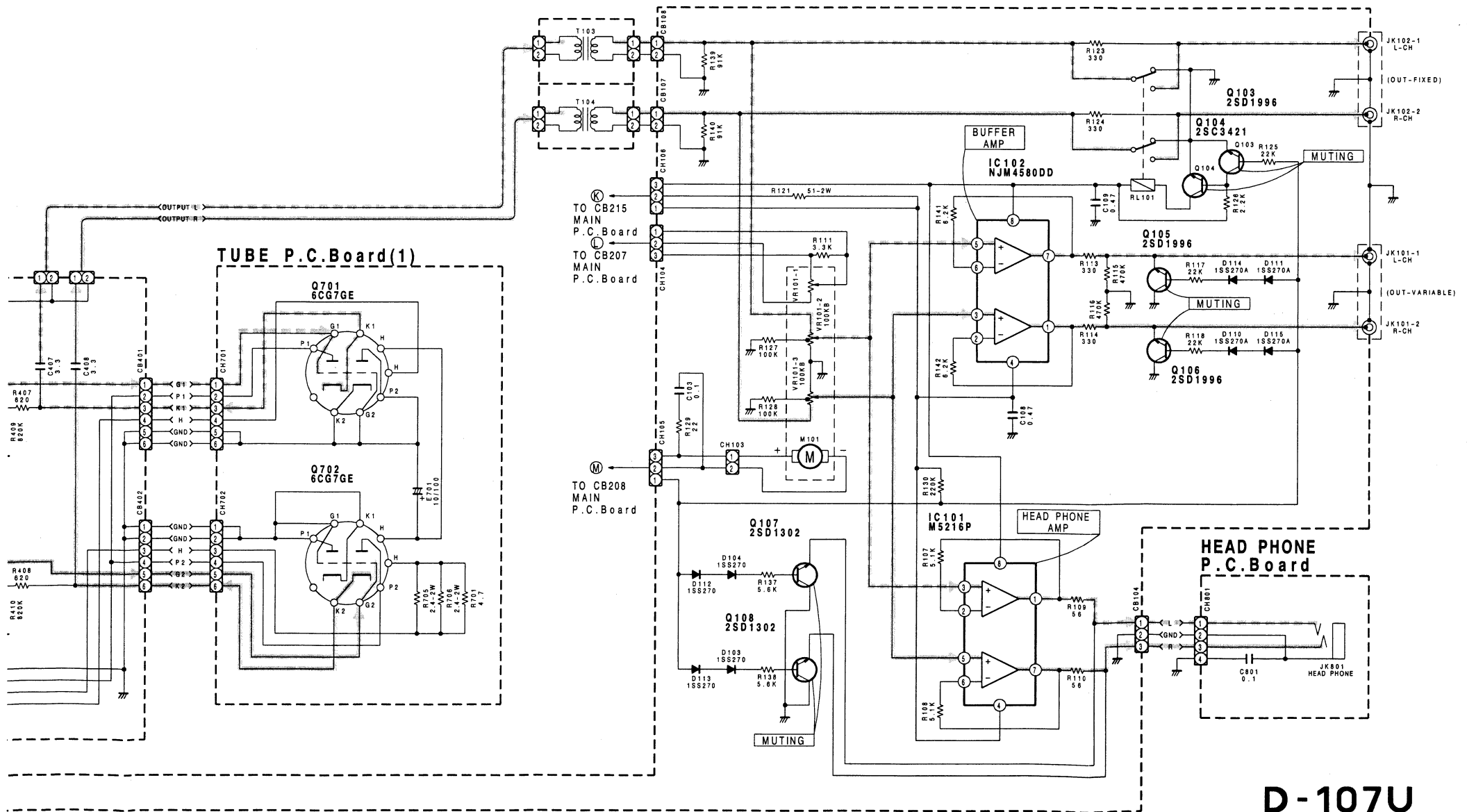
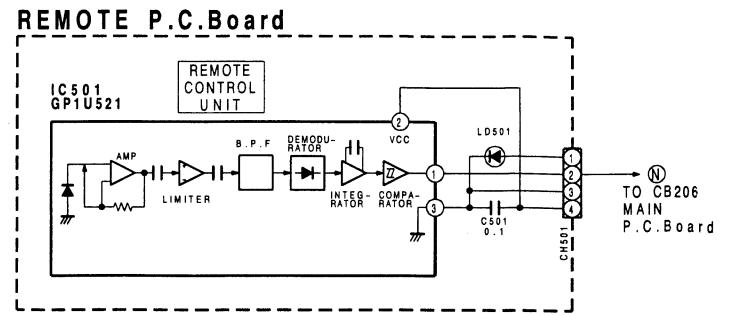
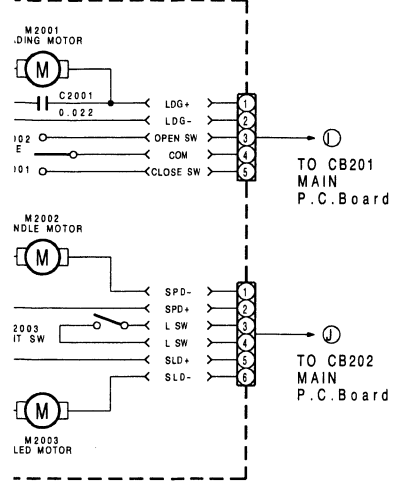
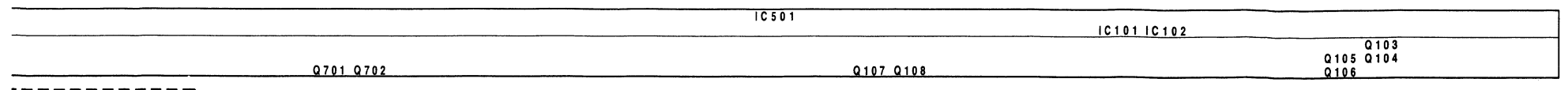

D-107U

# Schematic Diagram (2/3) <AD model>

IC'S	IC203 IC204	IC215	IC214	IC202	Q204
TRANSISTORS (Q)	Q220	Q223 Q224	Q225 Q226		
		Q212 Q213			

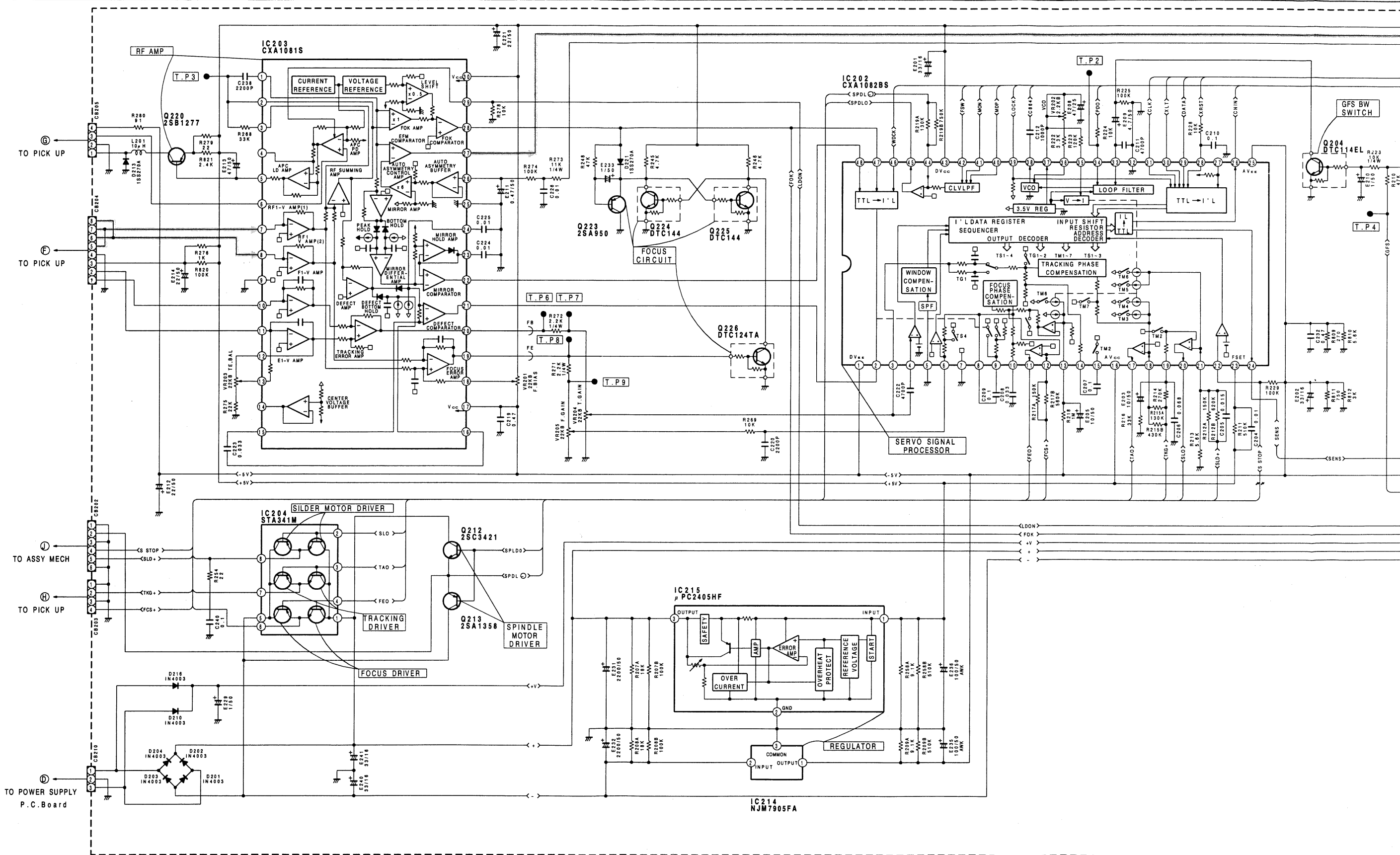

A | B | C | D | E | F | G | H

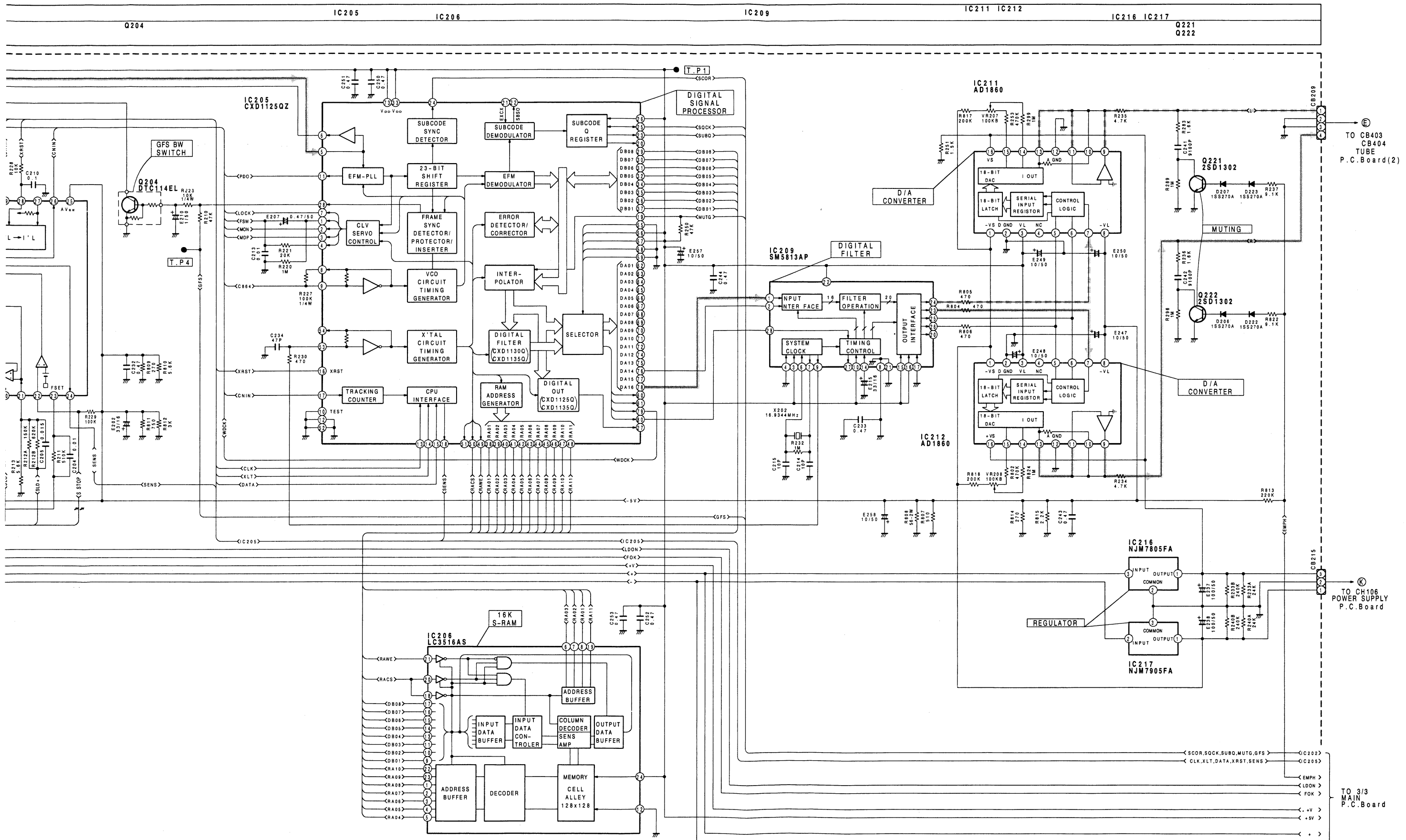

TO CB403  
CB404  
TUBE  
P.C. Board(2)

TO CH106  
POWER SUPPLY  
P.C. Board

TO 3/3  
MAIN  
P.C. Board

**D-107U**

# Schematic Diagram(2/3) <JA model>

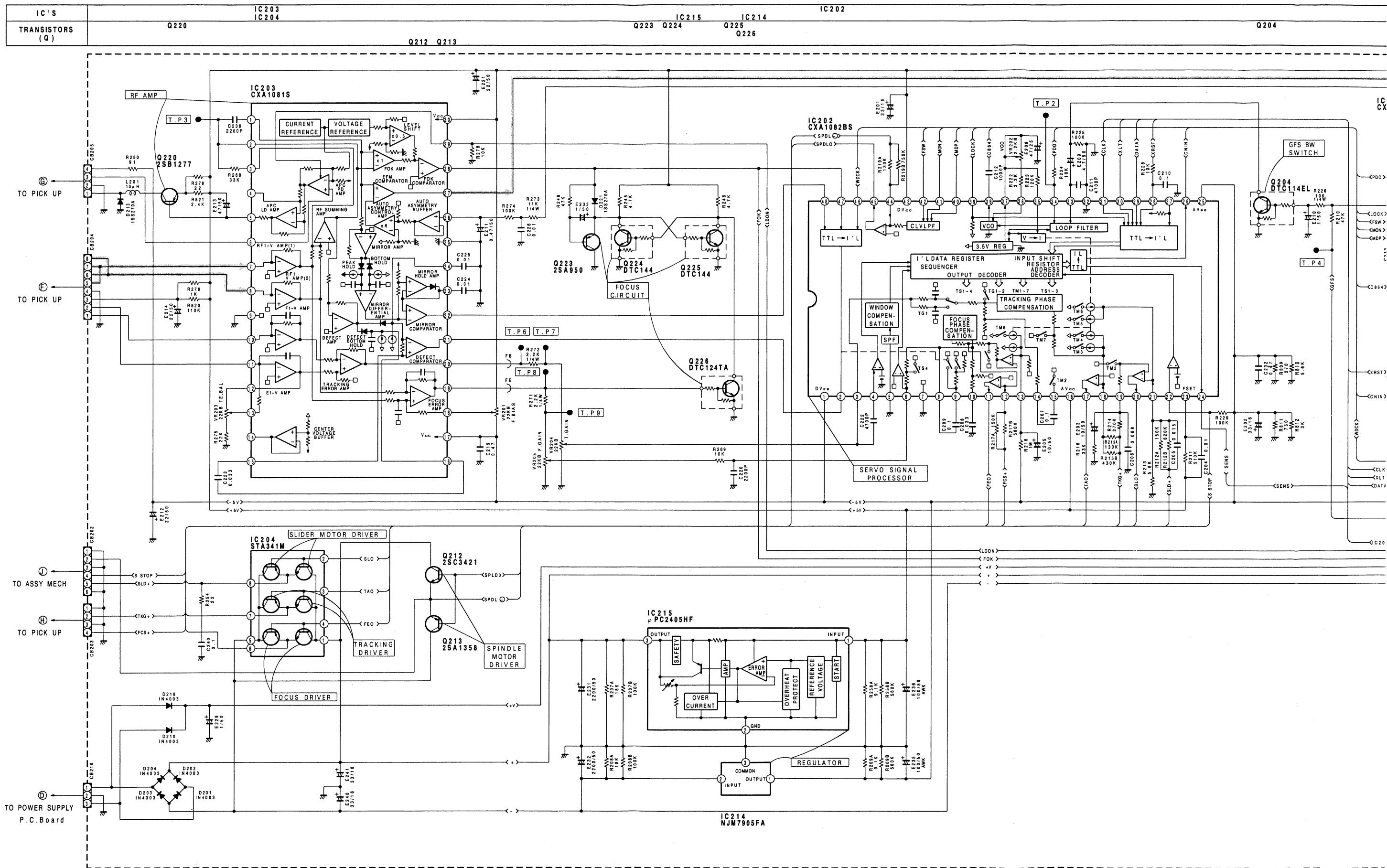

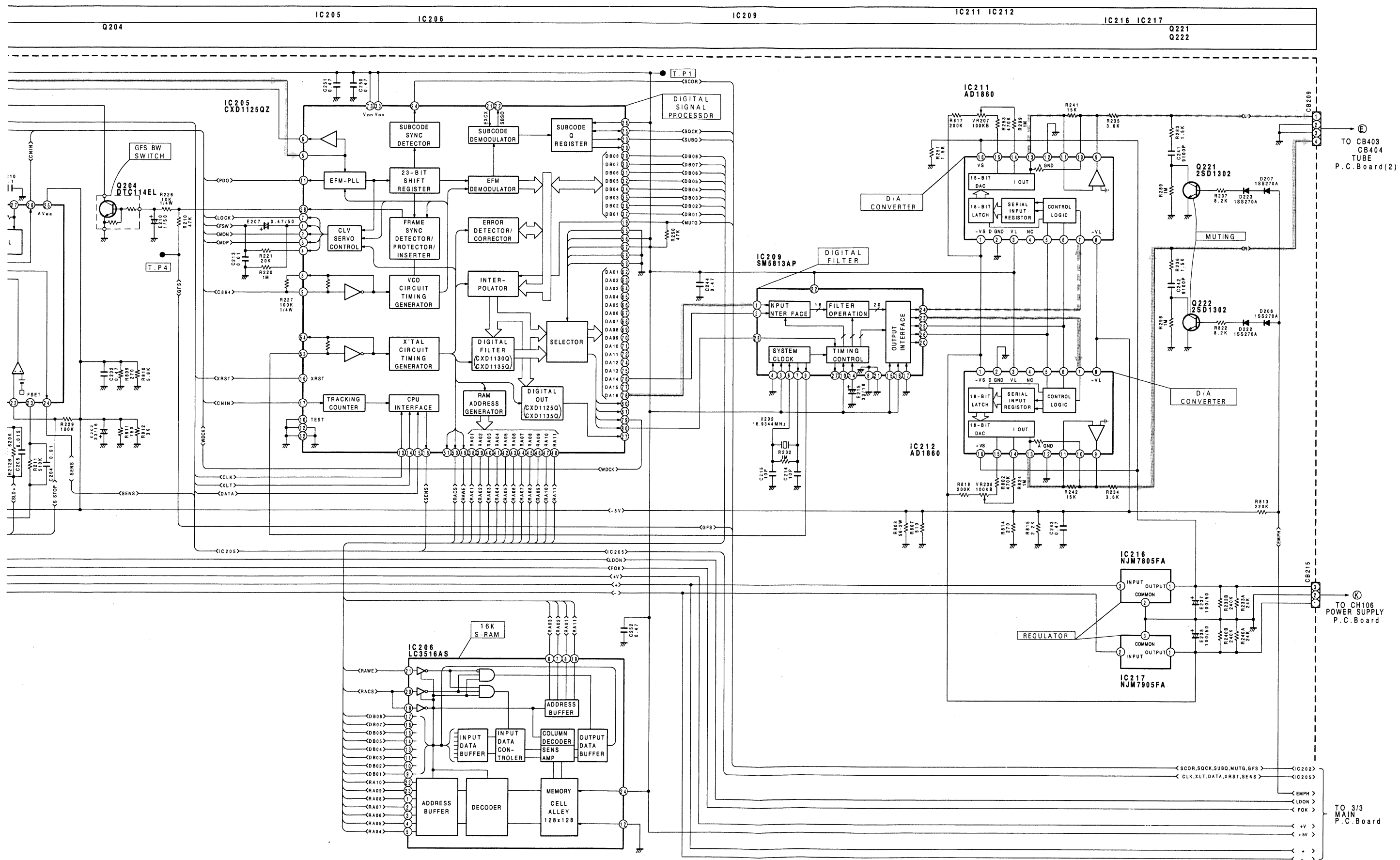

TO CB403  
CB404  
TUBE  
P.C. Board(2)

TO CH106  
POWER SUPPLY  
P.C. Board

TO 3/3  
MAIN  
P.C. Board

D-107U

H | I | J | K | L | M | N | O | P

# Schematic Diagram(3/3) <AD model>

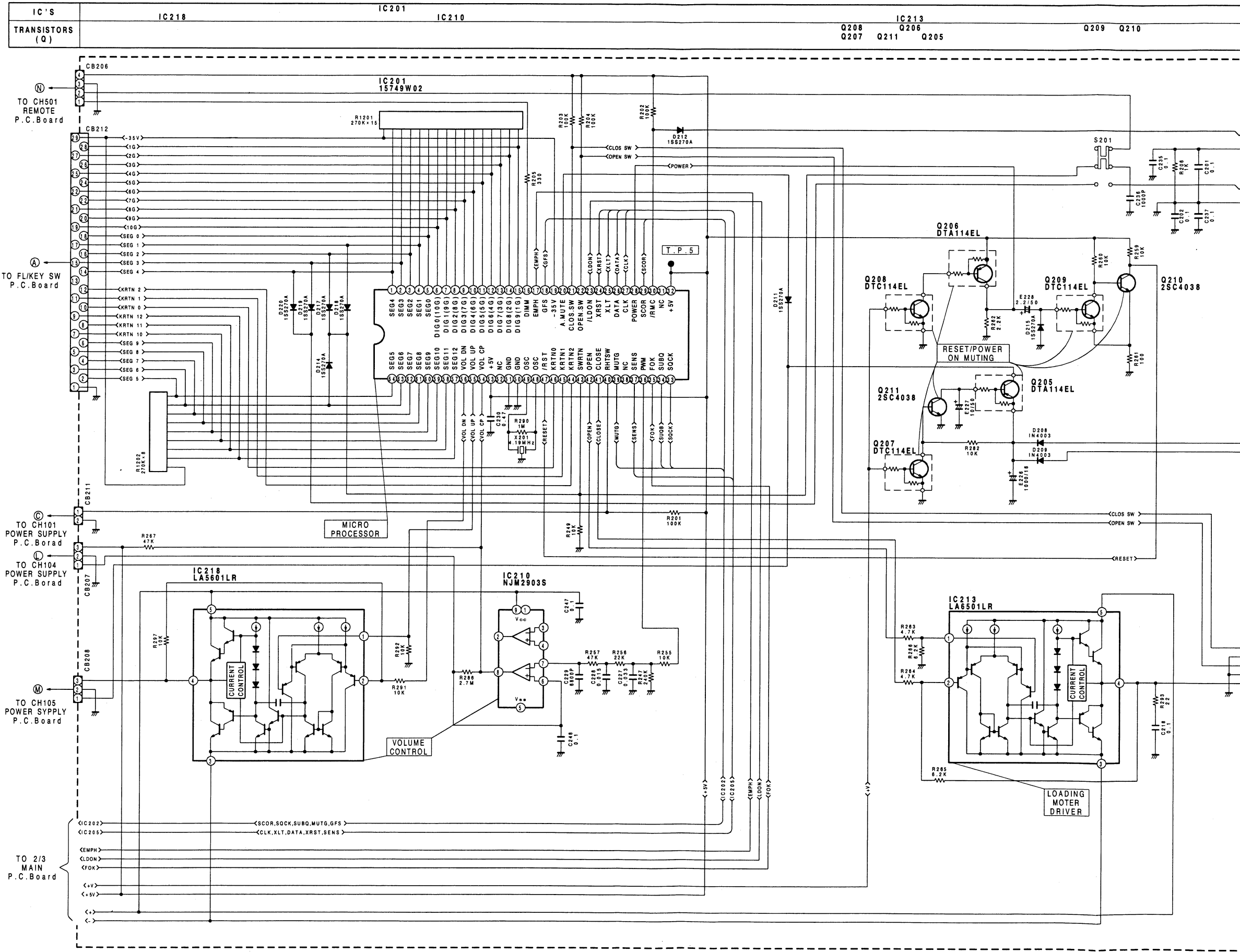

**NOTE**  
 1. All resistance values are in ohms. K= 1000, M= 1000000.  
 2. All capacitance values are in microfarads.

**Voltage Measuring Conditions**  
 1. Power Supply Voltage : AC120/220/240  
 2. Measuring Meter : Digital Multimeter  
 3. Measuring Point Reference : Between Ground  
 4. Measuring Conditions : NO Signal Input, AT Play Mode (Use the 2nd time)

IC201	IC205	IC209	IC210	IC213	IC215	IC216
1 -29.3V 33 5V	1 0V 41 2.4V	1 0V 50 2.6V	1 0V 50 2.6V	1 1.5V 51 1.2	1 15.7V -4.9V 5.7V 5V	1 15.7V -4.9V 5.7V 5V
2 -22.6V 34 1.4V	2 -4.8V 42 2.4V	2 1.5V 51 1.2	2 0V 50 2.6V	2 2.5V 43 2.4V	2 0V -12.8V 0V 0V	2 0V -12.8V 0V 0V
3 -27V 35 4.9V	3 2.5V 43 2.4V	3 4.9V 53 2.3V	3 4.9V 53 2.3V	3 4.9V 53 2.3V	3 11.9V 0V 12V 12V	3 11.9V 0V 12V 12V
4 -27V 36 0V	4 2.7V 44 2.5V	4 5V 54 1.4	4 5V 54 1.4	4 5V 54 1.4		
5 -22.6V 37 4.8V	5 2.4V 45 2.5V	5 1.4V 55 0V	5 1.4V 55 0V	5 1.4V 55 0V		
6 -32.8V 38 7	6 2.6V 46 2.8V	6 5V 56 4.9V	6 5V 56 4.9V	6 5V 56 4.9V		
7 -32.8V 39 0V	7 2.9V 47 2V	7 0V 57 4.9V	7 0V 57 4.9V	7 0V 57 4.9V		
8 -32.8V 40 0V	8 2.4V 48 2V	8 4.8V 58 0V	8 4.8V 58 0V	8 4.8V 58 0V		
9 -32.8V 41 0V	9 2.4V 49 4.3V	9 0V 59 0V	9 0V 59 0V	9 0V 59 0V		
10 -32.8V 42 0V	10 0V 50 2.6V	10 1.9V 60 1.0	10 1.9V 60 1.0	10 1.9V 60 1.0		
11 -32.8V 43 2.2V	11 1.5V 51 1.2	11 1.9V 71 1.1	11 1.9V 71 1.1	11 1.9V 71 1.1		
12 -32.8V 44 -19V	12 0V 52 1.1	12 1.9V 72 1.1	12 1.9V 72 1.1	12 1.9V 72 1.1		
13 -32.8V 45 -19.1V	13 4.9V 53 2.3V	13 4.9V 73 4.9V	13 4.9V 73 4.9V	13 4.9V 73 4.9V		
14 -32.8V 46 -18.7V	14 5V 54 1.4	14 1.9V 74 1.1	14 1.9V 74 1.1	14 1.9V 74 1.1		
15 -32.8V 47 0V	15 1.4V 55 0V	15 1.9V 75 1.1	15 1.9V 75 1.1	15 1.9V 75 1.1		
16 0V 48 2.3V	16 2.6V 46 2.8V	16 5V 56 4.9V	16 5V 56 4.9V	16 5V 56 4.9V		
17 -7.6V 49 2.3V	17 2.9V 47 2V	17 0V 57 4.9V	17 0V 57 4.9V	17 0V 57 4.9V		
18 4.8V 50 0V	18 2.4V 48 2V	18 4.8V 58 0V	18 4.8V 58 0V	18 4.8V 58 0V		
19 -35.8V 51 0V	19 2.4V 49 4.3V	19 0V 59 0V	19 0V 59 0V	19 0V 59 0V		
20 -7.4V 52 1.1	20 0V 50 2.6V	20 1.9V 60 1.0	20 1.9V 60 1.0	20 1.9V 60 1.0		
21 0V 53 5V	21 1.5V 51 1.2	21 1.9V 71 1.1	21 1.9V 71 1.1	21 1.9V 71 1.1		
22 5V 54 0V	22 0V 52 1.1	22 1.9V 72 1.1	22 1.9V 72 1.1	22 1.9V 72 1.1		
23 0.4V 55 0V	23 4.9V 53 2.3V	23 4.9V 73 4.9V	23 4.9V 73 4.9V	23 4.9V 73 4.9V		
24 5V 56 0V	24 5V 54 1.4	24 1.9V 74 1.1	24 1.9V 74 1.1	24 1.9V 74 1.1		
25 5V 57 -22.2V	25 1.4V 55 0V	25 1.9V 75 1.1	25 1.9V 75 1.1	25 1.9V 75 1.1		
26 1.4V 58 -24.2V	26 2.6V 46 2.8V	26 5V 56 4.9V	26 5V 56 4.9V	26 5V 56 4.9V		
27 1.4V 59 -23.8V	27 2.9V 47 2V	27 0V 57 4.9V	27 0V 57 4.9V	27 0V 57 4.9V		
28 4.9V 60 -17.1V	28 2.4V 48 2V	28 4.8V 58 0V	28 4.8V 58 0V	28 4.8V 58 0V		
29 0V 61 -10.1V	29 2.4V 49 4.3V	29 0V 59 0V	29 0V 59 0V	29 0V 59 0V		
30 4.8V 62 -15.6V	30 0V 50 2.6V	30 1.9V 60 1.0	30 1.9V 60 1.0	30 1.9V 60 1.0		
31 5V 63 -22.5V	31 1.5V 51 1.2	31 1.9V 71 1.1	31 1.9V 71 1.1	31 1.9V 71 1.1		
32 5V 64 -29.8V	32 0V 52 1.1	32 1.9V 72 1.1	32 1.9V 72 1.1	32 1.9V 72 1.1		



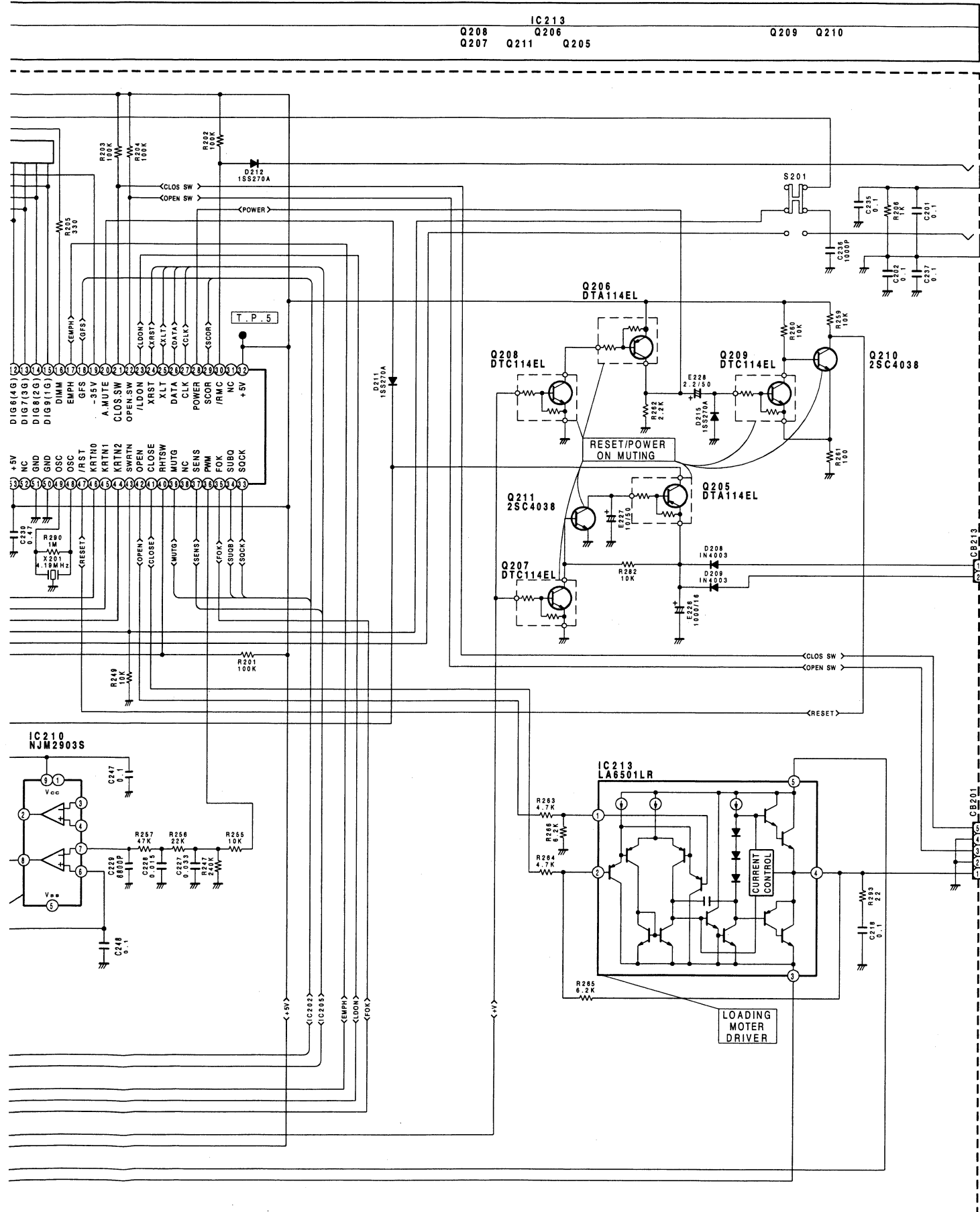

**NOTE**  
 1. All resistance values are in ohms. K=1,000 M=1,000,000  
 2. All capacitance values are in microfarads. P= $\frac{1}{1,000,000}$

**Voltage Measuring Conditions**  
 1. Power Supply Voltage : AC120/220/240V, 50Hz  
 2. Measuring Meter : Digital Multimeter  
 3. Measuring Point Reference : Between Ground  
 4. Measuring Conditions : NO Signal Input  
 AT Play Mode Test CD  
 (Use the 2nd trak on the YEDS-18)

**CAUTION:**  
 The symbol numbers in the schematic diagram designate components which have special characteristics important for safety and should be replaced only with types identical to those in the original circuit or specified in the parts list.

**IC201**

1	-29.3V	33	5V
2	-22.6V	34	1.4V
3	-27V	35	4.9V
4	-27V	36	0V
5	-22.6V	37	4.8V
6	-32.8V	38	—
7	-32.8V	39	0V
8	-32.8V	40	0V
9	-32.8V	41	0V
10	-32.8V	42	0V
11	-32.8V	43	2.2V
12	-32.8V	44	-19V
13	-32.8V	45	-19.1V
14	-32.8V	46	-18.7V
15	-32.8V	47	0V
16	0V	48	2.3V
17	-7.6V	49	2.3V
18	4.8V	50	0V
19	-35.8V	51	0V
20	-7.4V	52	—
21	0V	53	5V
22	5V	54	0V
23	0.4V	55	0V
24	5V	56	0V
25	5V	57	-22.2V
26	1.4V	58	-24.2V
27	1.4V	59	-23.8V
28	4.9V	60	-17.1V
29	0V	61	-10.1V
30	4.8V	62	-15.6V
31	—	63	-22.5V
32	5V	64	-29.8V

**IC203**

1	0V
2	1.1V
3	0V
4	2.5V
5	2.8V
6	-4.8V
7	0V
8	0V
9	0V
10	0V
11	0V
12	-0.6V
13	-0.4V
14	0V
15	-2.2V
16	-1.9V
17	-4.9V
18	0V
19	0V
20	0V
21	-4.8V
22	0V
23	-1.7V
24	-1.2V
25	0V
26	2.4V
27	2.4V
28	4.9V
29	0.2V
30	4.9V

**IC202**

1	-4.9V	25	-4.9V
2	-4.9V	26	0V
3	0V	27	—
4	0V	28	5V
5	0V	29	0V
6	0V	30	5V
7	0V	31	5V
8	0V	32	0V
9	0V	33	2.4V
10	0V	34	2.5V
11	1V	35	2.3V
12	0V	36	2.3V
13	0.3V	37	3.5V
14	0V	38	2.5V
15	0V	39	4.9V
16	4.9V	40	2.5V
17	0V	41	4.8V
18	-3.2V	42	2.5V
19	0V	43	4.9V
20	1V	44	0V
21	0V	45	1.1V
22	-4.9V	46	2.4V
23	-4V	47	0V
24	4.8V	48	0V

**IC206**

1	2.5V
2	2.5V
3	2.4V
4	2.4V
5	2.4V
6	2.4V
7	2.4V
8	2.4V
9	1.9V
10	1.9V
11	1.9V
12	0V
13	1.9V
14	1.9V
15	1.9V
16	1.9V
17	2V
18	2.6V
19	3V
20	2.6V
21	4.3V
22	2V
23	2.8V
24	4.9V

**IC205**

1	0V	41	2.4V
2	-4.8V	42	2.4V
3	2.5V	43	2.4V
4	2.7V	44	2.5V
5	2.4V	45	2.5V
6	2.6V	46	2.8V
7	4.9V	47	2V
8	2.4V	48	2V
9	2.4V	49	4.3V
10	0V	50	2.6V
11	1.5V	51	—
12	0V	52	0V
13	4.9V	53	2.3V
14	5V	54	—
15	1.4V	55	0V
16	5V	56	4.9V
17	0V	57	4.9V
18	4.8V	58	0V
19	0V	59	0V
20	—	60	—
21	—	61	—
22	—	62	—
23	1.4V	63	—
24	0V	64	—
25	5V	65	—
26	4.9V	66	—
27	2.3V	67	—
28	4.9V	68	—
29	2V	69	—
30	1.9V	70	—
31	1.9V	71	—
32	1.9V	72	—
33	4.9V	73	4.9V
34	1.9V	74	—
35	1.9V	75	—
36	1.9V	76	2.3V
37	1.9V	77	—
38	2.4V	78	2.5V
39	2.4V	79	2.4V
40	2.4V	80	2.5V

**IC204**

1	11.2V
2	0.6V
3	0V
4	0V
5	-12V
6	0.6V
7	0V
8	0V

**IC211 IC212**

1	-4.9V	-4.9V
2	0V	0V
3	4.9V	4.9V
4	0V	0V
5	1.8V	1.8V
6	3.6V	3.6V
7	1.8V	1.8V
8	-4.9V	-4.9V
9	0V	0V
10	0V	0V
11	0V	0V
12	0V	0V
13	0V	0V
14	-2.4V	-2.4V
15	2.4V	2.4V
16	4.9V	4.9V

**IC101 IC102 IC210**

1	0V	0V	0V
2	0V	0V	0V
3	0V	0V	-8V
4	-5V	-5V	0V
5	0V	0V	—
6	0V	0V	—
7	0V	0V	—
8	5V	5V	12V

**IC213 IC218**

1	0-4.9V	0-4.9V
2	-4.9-4.9V	-4.9-4.9V
3	-12.8V	-12.8V
4	-4.9-4.9V	-4.9-4.9V
5	12V	12V

	E	C	B
Q101	-30.2V	-43.8V	-30.7V
Q102	85.1V	130.5V	85.6V
Q103	0V	0V	-7.6V
Q104	0V	0V	-7.6V
Q105	0V	0V	-7.6V
Q106	0V	0V	-7.6V
Q107	0V	0V	-7.6V
Q108	0V	0V	-7.6V
Q204	0V	0V	2.8V
Q205	11.7V	-7.5V	0V
Q206	4.9V	4.9V	0V
Q207	0V	0V	6.3V
Q208	0V	0V	6.3V
Q209	0V	0V	0V
Q210	0V	0V	0V
Q211	0V	0V	0V
Q212	0.6V	11.2V	1V
Q213	0.6V	-12V	1V
Q220	4V	1.8V	2.8V
Q221	0V	0V	0.6V
Q222	0V	0V	0.6V
Q223	4.5V	0V	4.8V
Q224	0V	4.5V	0V
Q225	0V	0V	4.5V
Q226	0V	0V	0V

**IC105 IC214 IC215 IC216 IC217 IC501**

1	15.7V	-4.9V	5.7V	5V	-5V	5V
2	0V	-12.8V	0V	0V	-12.8V	5V
3	11.9V	0V	12V	12V	0V	0V

**D-107U**

# Schematic Diagram (3/3) <JA model>

IC'S	IC218	IC201	IC210	IC213	Q208	Q206	Q205	Q209	Q210
TRANSISTORS (Q)					Q207	Q211	Q205		

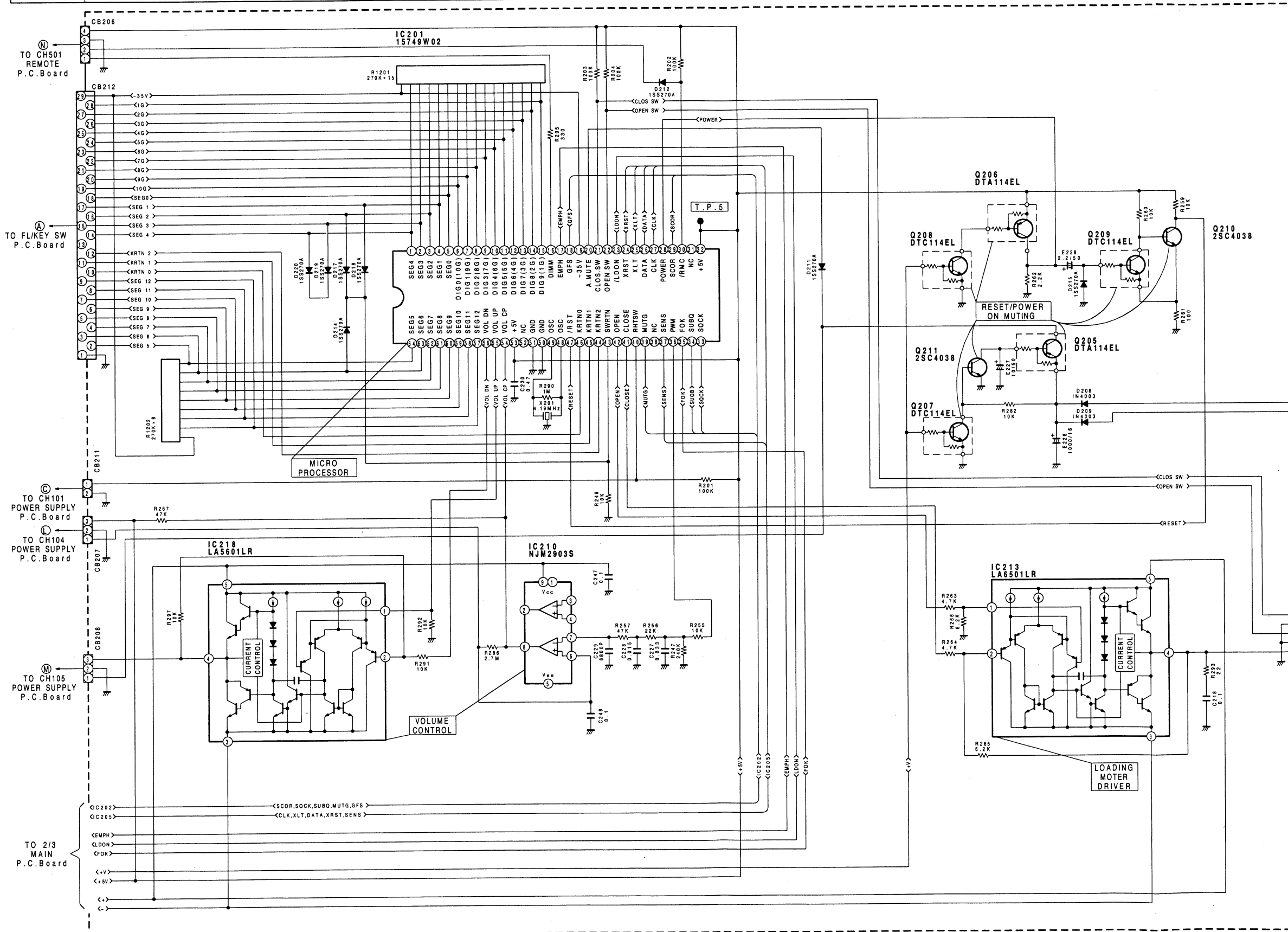

**NOTE**  
 1. All resistance values are in ohms. K=1,000 M  
 2. All capacitance values are in microfarads. P=μF

**Voltage Measuring Conditions**  
 1. Power Supply Voltage : AC100V, 50/60Hz  
 2. Measuring Meter : Digital Multimeter  
 3. Measuring Point Reference : Between Ground  
 4. Measuring Conditions : NO Signal Input  
 (Use the 2nd trak on

IC201				IC203			
1	-29.3V	33	5V	1	0V		
2	-22.6V	34	1.4V	2	1.1V		
3	-27V	35	4.9V	3	0V		
4	-27V	36	0V	4	2.5V		
5	-22.6V	37	4.8V	5	2.8V		
6	-32.8V	38		6	-4.8V		
7	-32.8V	39	0V	7	0V		
8	-32.8V	40	0V	8	0V		
9	-32.8V	41	0V	9	0V		
10	-32.8V	42	0V	10	0V		
11	-32.8V	43	2.2V	11	-0.6V		
12	-32.8V	44	-1.9V	12	-0.4V		
13	-32.8V	45	-1.9V	13	0.4V		
14	-32.8V	46	-1.8V	14	0V		
15	-32.8V	47	0V	15	-2.2V		
16	0V	48	2.3V	16	-1.9V		
17	-7.6V	49	2.3V	17	-4.9V		
18	4.8V	50	0V	18	0V		
19	-35.6V	51	0V	19	0V		
20	-7.4V	52		20	0V		
21	0V	53	5V	21	-4.8V		
22	5V	54	0V	22	0V		
23	0.4V	55	0V	23	-1.7V		
24	5V	56	0V	24	-1.2V		
25	5V	57	2.2V	25	0V		
26	1.4V	58	2.2V	26	2.4V		
27	1.4V	59	2.3V	27	2.4V		
28	4.9V	60	-1.1V	28	4.9V		
29	0V	61	-1.0V	29	0.2V		
30	4.8V	62	1.5V	30	4.9V		
31		63	2.5V	31	0V		
32	5V	64	2.9V	32	4.9V		

IC205				IC204				IC209			
1	0V	41	2.4V	1	11.2V			1	2.5V		
2	-4.8V	42	2.4V	2	0.6V			2	2.3V		
3	2.5V	43	2.4V	3	0V			3	4.9V		
4	2.7V	44	2.5V	4	0V			4	4.9V		
5	2.4V	45	2.5V	5	-12V			5	2.6V		
6	2.6V	46	2.5V	6	0.6V			6	2.6V		
7	4.9V	47	2V	7	0V			7	0V		
8	2.4V	48	2V	8	0V			8	0V		
9	2.4V	49	4.3V	9	2V			9	2V		
10	0V	50	2.6V	10	4.9V			10	4.9V		
11	1.5V	51		11				11			
12	0V	52	0V	12				12			
13	4.9V	53	2.3V	13				13			
14	5V	54		14				14			
15	1.4V	55	0V	15				15			
16	5V	56	4.9V	16				16			
17	0V	57	4.9V	17				17			
18	4.8V	58	0V	18				18			
19	0V	59	0V	19				19			
20		60		20				20			
21		61		21				21			
22		62		22				22			
23	1.4V	63		23				23			
24	0V	64		24				24			
25	5V	65		25				25			
26	4.9V	66		26				26			
27	2.3V	67		27				27			
28	4.9V	68		28				28			
29	2V	69		29				29			
30	1.9V	70		30				30			
31	1.9V	71		31				31			
32	1.9V	72		32				32			
33	4.9V	73	4.9V	33				33			
34	1.9V	74		34				34			
35	1.9V	75		35				35			
36	1.9V	76	2.3V	36				36			
37	1.9V	77		37				37			
38	2.4V	78	2.5V	38				38			
39	2.4V	79	2.4V	39				39			
40	2.4V	80	2.5V	40				40			

IC105	IC214	IC215	IC216	IC217
1	15.7V	-4.1V	5.7V	5V
2	0V	-12.8V	0V	0V
3	11.9V	0V	12V	12V

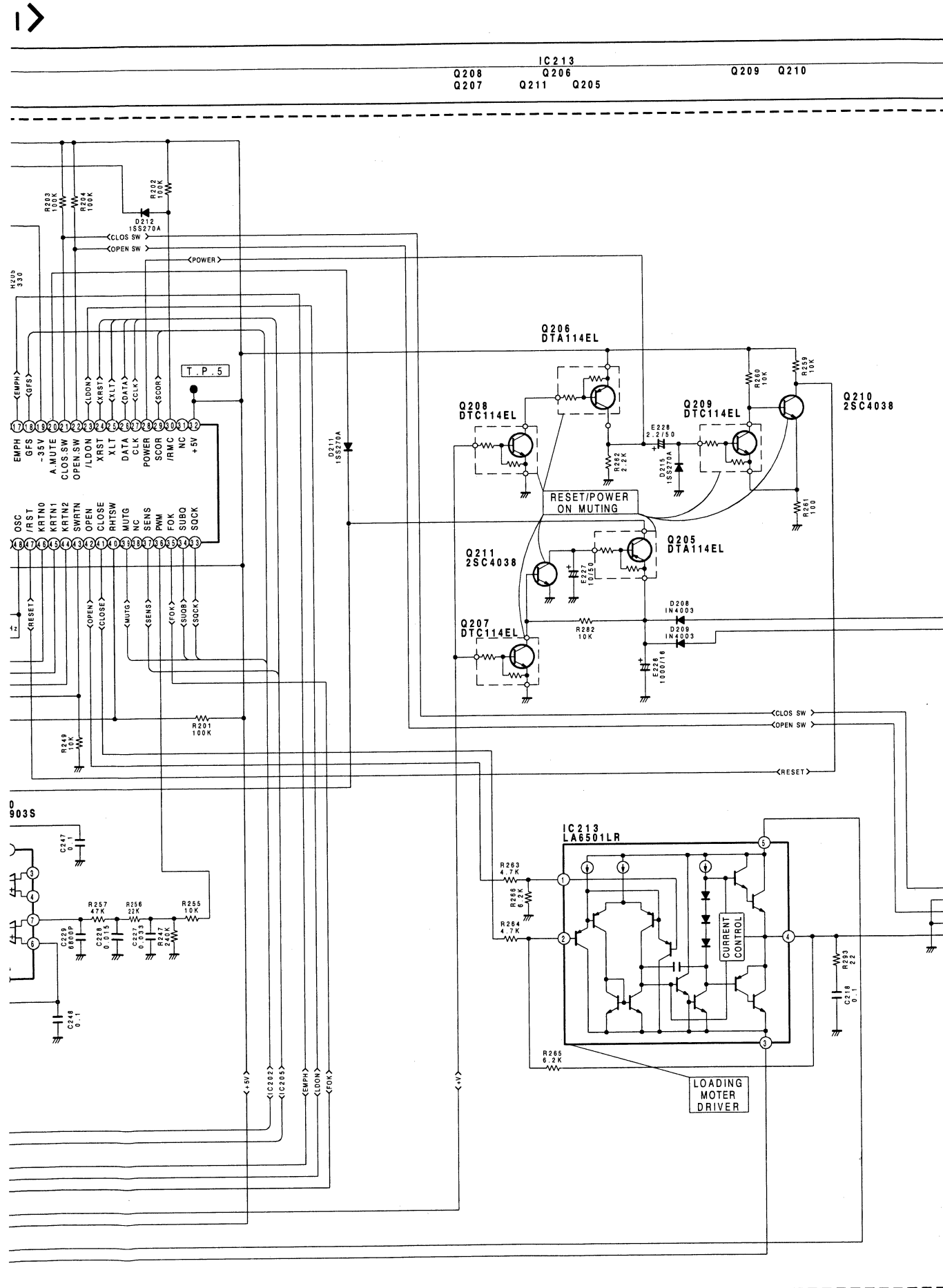

IC213  
Q208 Q206 Q209 Q210  
Q207 Q211 Q205

**NOTE**  
1. All resistance values are in ohms. K=1,000 M=1,000,000  
2. All capacitance values are in microfarads. P= $\frac{1}{1,000,000}$

**Voltage Measuring Conditions**  
1. Power Supply Voltage : AC100V, 50/60Hz  
2. Measuring Meter : Digital Multimeter  
3. Measuring Point Reference : Between Ground  
4. Measuring Conditions : NO Signal Input  
AT Play Mode Test CD  
(Use the 2nd track on the YEDS-18)

**CAUTION:**  
The  $\Delta$  mark, the symbol numbers in the schematic diagram designate components which have special characteristics important for safety and should be replaced only with types identical to those in the original circuit or specified in the parts list.

**IC201**

1	-29.3V	33	5V
2	-22.6V	34	1.4V
3	-27V	35	4.9V
4	-27V	36	0V
5	-22.6V	37	4.8V
6	-32.8V	38	—
7	-32.8V	39	0V
8	-32.8V	40	0V
9	-32.8V	41	0V
10	-32.8V	42	0V
11	-32.8V	43	2.2V
12	-32.8V	44	-19.1V
13	-32.8V	45	-19.1V
14	-32.8V	46	-18.7V
15	-32.8V	47	0V
16	0V	48	2.3V
17	-7.6V	49	2.3V
18	4.8V	50	0V
19	-35.8V	51	0V
20	-7.4V	52	—
21	0V	53	5V
22	5V	54	0V
23	0.4V	55	0V
24	5V	56	0V
25	5V	57	-22.2V
26	1.4V	58	-24.2V
27	1.4V	59	-23.8V
28	4.9V	60	-17.1V
29	0V	61	-10.1V
30	4.8V	62	-15.6V
31	—	63	-22.5V
32	5V	64	-29.8V

**IC203**

1	0V
2	1.1V
3	0V
4	2.5V
5	2.8V
6	-4.8V
7	0V
8	0V
9	0V
10	0V
11	0V
12	-0.6V
13	-0.4V
14	0V
15	-2.2V
16	-1.9V
17	-4.9V
18	0V
19	0V
20	0V
21	-4.8V
22	0V
23	-1.7V
24	-1.2V
25	0V
26	2.4V
27	2.4V
28	4.9V
29	0.2V
30	4.9V

**IC202**

1	-4.9V	25	-4.9V
2	-4.9V	26	0V
3	0V	27	—
4	0V	28	5V
5	0V	29	0V
6	0V	30	5V
7	0V	31	5V
8	0V	32	0V
9	0V	33	2.4V
10	0V	34	2.5V
11	1V	35	2.3V
12	0V	36	2.3V
13	0.3V	37	3.5V
14	0V	38	2.5V
15	0V	39	4.9V
16	4.9V	40	2.5V
17	0V	41	4.8V
18	-3.2V	42	2.5V
19	0V	43	4.9V
20	1V	44	0V
21	0V	45	1.1V
22	-4.9V	46	2.4V
23	-4V	47	0V
24	4.8V	48	0V

**IC206**

1	2.5V
2	2.5V
3	2.4V
4	2.4V
5	2.4V
6	2.4V
7	2.4V
8	2.4V
9	1.9V
10	1.9V
11	1.9V
12	0V
13	1.9V
14	1.9V
15	1.9V
16	1.9V
17	2V
18	2.6V
19	3V
20	2.6V
21	4.3V
22	2V
23	4.3V
24	4.9V

**IC205**

1	0V	41	2.4V
2	-4.8V	42	2.4V
3	2.5V	43	2.4V
4	2.7V	44	2.5V
5	2.4V	45	2.5V
6	2.6V	46	2.8V
7	4.9V	47	2V
8	2.4V	48	2V
9	2.4V	49	4.3V
10	0V	50	2.6V
11	1.5V	51	—
12	0V	52	0V
13	4.9V	53	2.3V
14	5V	54	—
15	1.4V	55	0V
16	5V	56	4.9V
17	0V	57	4.9V
18	4.8V	58	0V
19	0V	59	0V
20	—	60	—
21	—	61	—
22	—	62	—
23	1.4V	63	—
24	0V	64	—
25	5V	65	—
26	4.9V	66	—
27	2.3V	67	—
28	4.9V	68	—
29	2V	69	—
30	1.9V	70	—
31	1.9V	71	—
32	1.9V	72	—
33	4.9V	73	4.9V
34	1.9V	74	—
35	1.9V	75	—
36	1.9V	76	2.3V
37	1.9V	77	—
38	2.4V	78	2.5V
39	2.4V	79	2.4V
40	2.4V	80	2.5V

**IC204**

1	11.2V
2	0.6V
3	0V
4	0V
5	-12V
6	0.6V
7	0V
8	0V

**IC211 IC212**

1	-4.9V	-4.9V
2	0V	0V
3	4.9V	4.9V
4	0V	0V
5	1.8V	1.8V
6	3.6V	3.6V
7	1.8V	1.8V
8	-4.9V	-4.9V
9	0V	0V
10	0V	0V
11	0V	0V
12	0V	0V
13	0V	0V
14	-2.4V	-2.4V
15	2.4V	2.4V
16	4.9V	4.9V

**IC101 IC102 IC210**

1	0V	0V	0V
2	0V	0V	0V
3	0V	0V	-8V
4	-5V	-5V	0V
5	0V	0V	—
6	0V	0V	—
7	0V	0V	—
8	5V	5V	12V

**IC213 IC218**

1	0	-4.9V	0	-4.9V
2	-4.9	-4.9V	-4.9	-4.9V
3	-12.8V	—	-12.8V	—
4	-4.9	-4.9V	-4.9	-4.9V
5	12V	—	12V	—

**IC105 IC214 IC215 IC216 IC217 IC501**

1	15.7V	-4.9V	5.7V	5V	-5V	5V
2	0V	-12.8V	0V	0V	-12.8V	5V
3	11.9V	0V	12V	12V	0V	0V

**D-107U**

# Parts Layout on P.C. Boards and Wiring Diagram (AD)

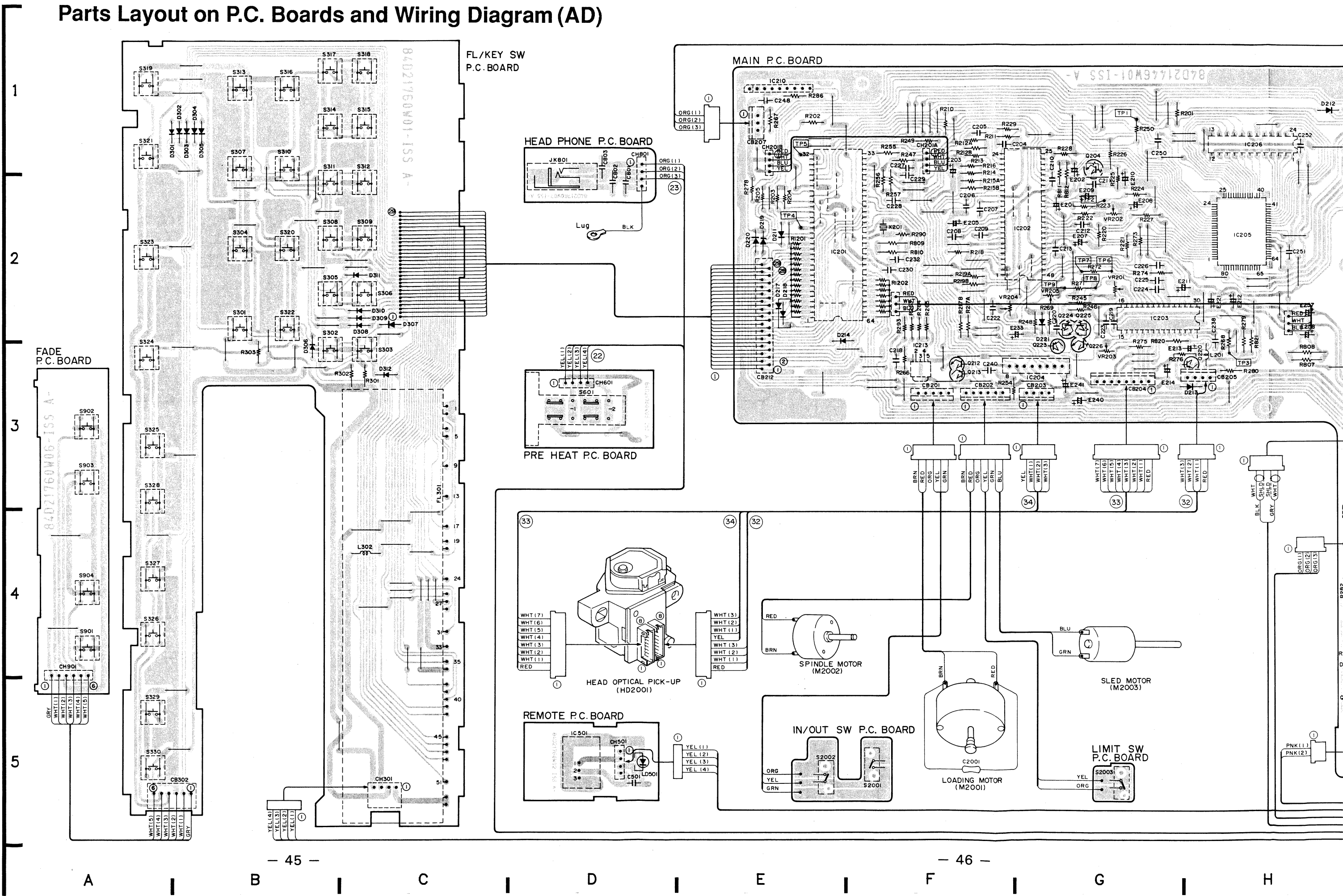



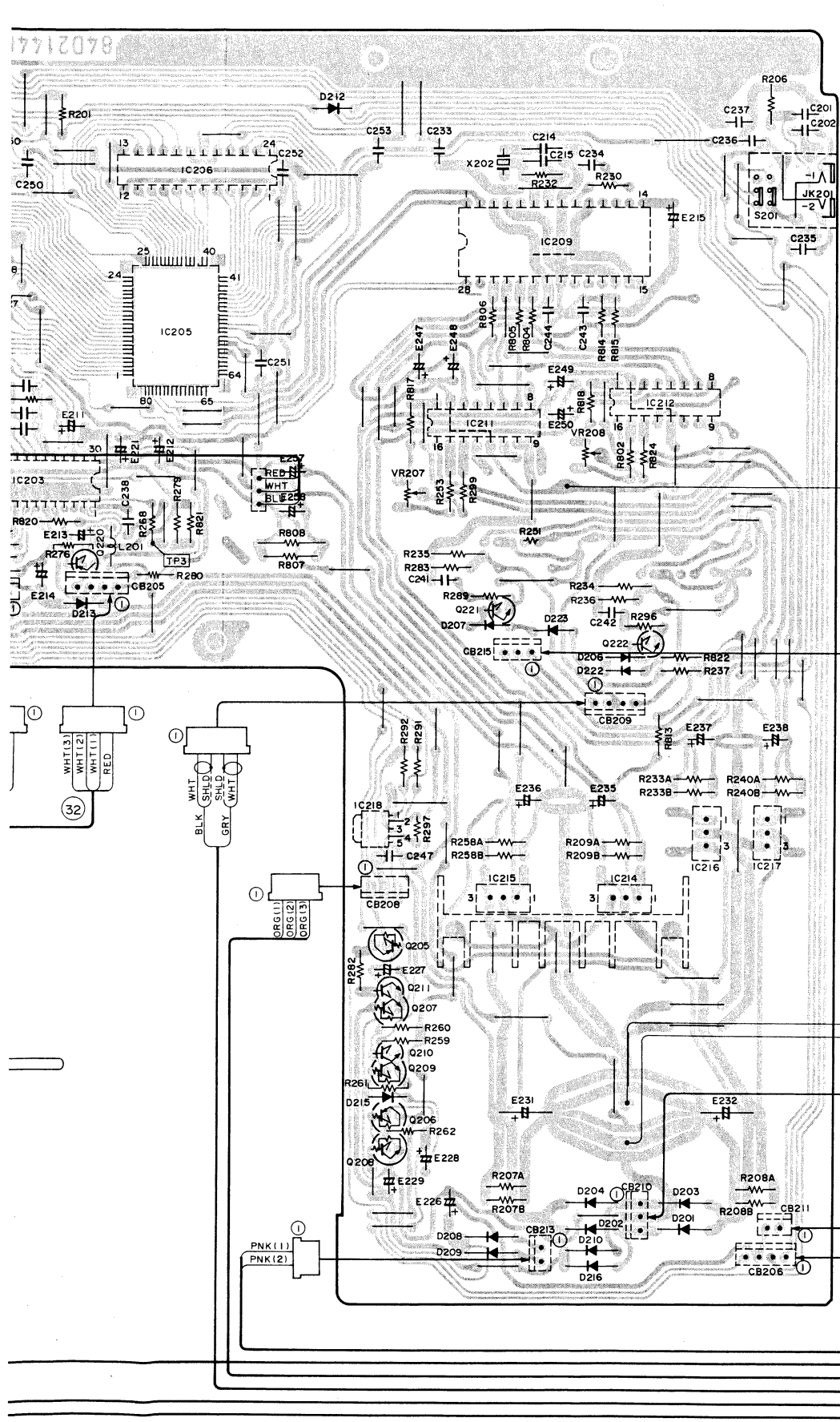

- Color Legend:
- BLU ..... Blue
  - GRN ..... Green
  - BLK ..... Black
  - GRY ..... Gray
  - WHT ..... White
  - RED ..... Red
  - BRN ..... Brown
  - ORG ..... Orange
  - YEL ..... Yellow
  - VLT ..... Violet
  - PNK ..... Pink
  - GRN/WHT ..... Green/White
  - GRY/WHT ..... Gray/White
  - GRY/YEL ..... Gray/Yellow
  - GRN/YEL ..... Green/Yellow
  - SHLD ..... Shield

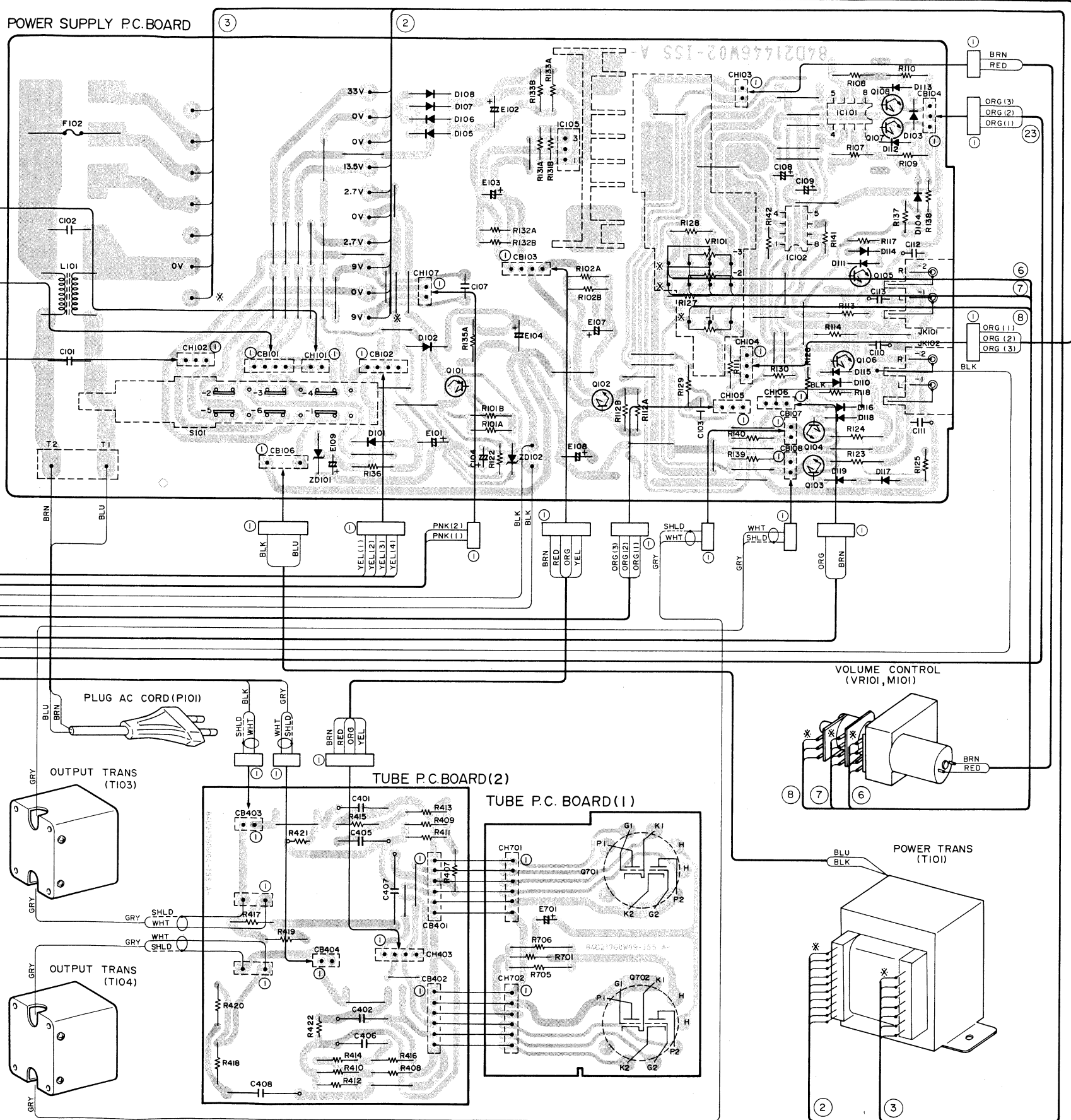

I | H | I | J | K | L | M | N | O

# Parts Layout on P.C. Boards and Wiring Diagram (JA)

1  
2  
3  
4  
5

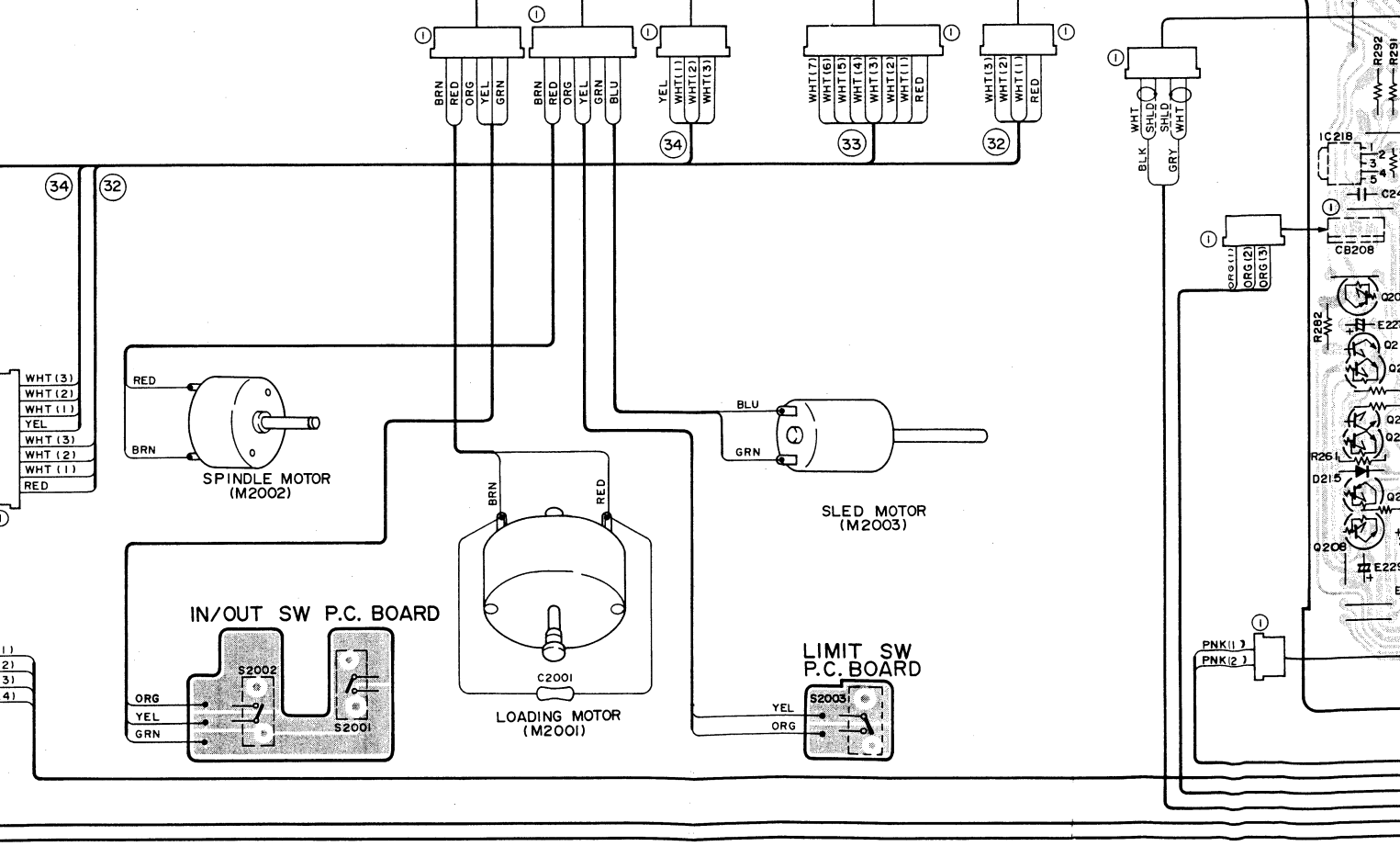
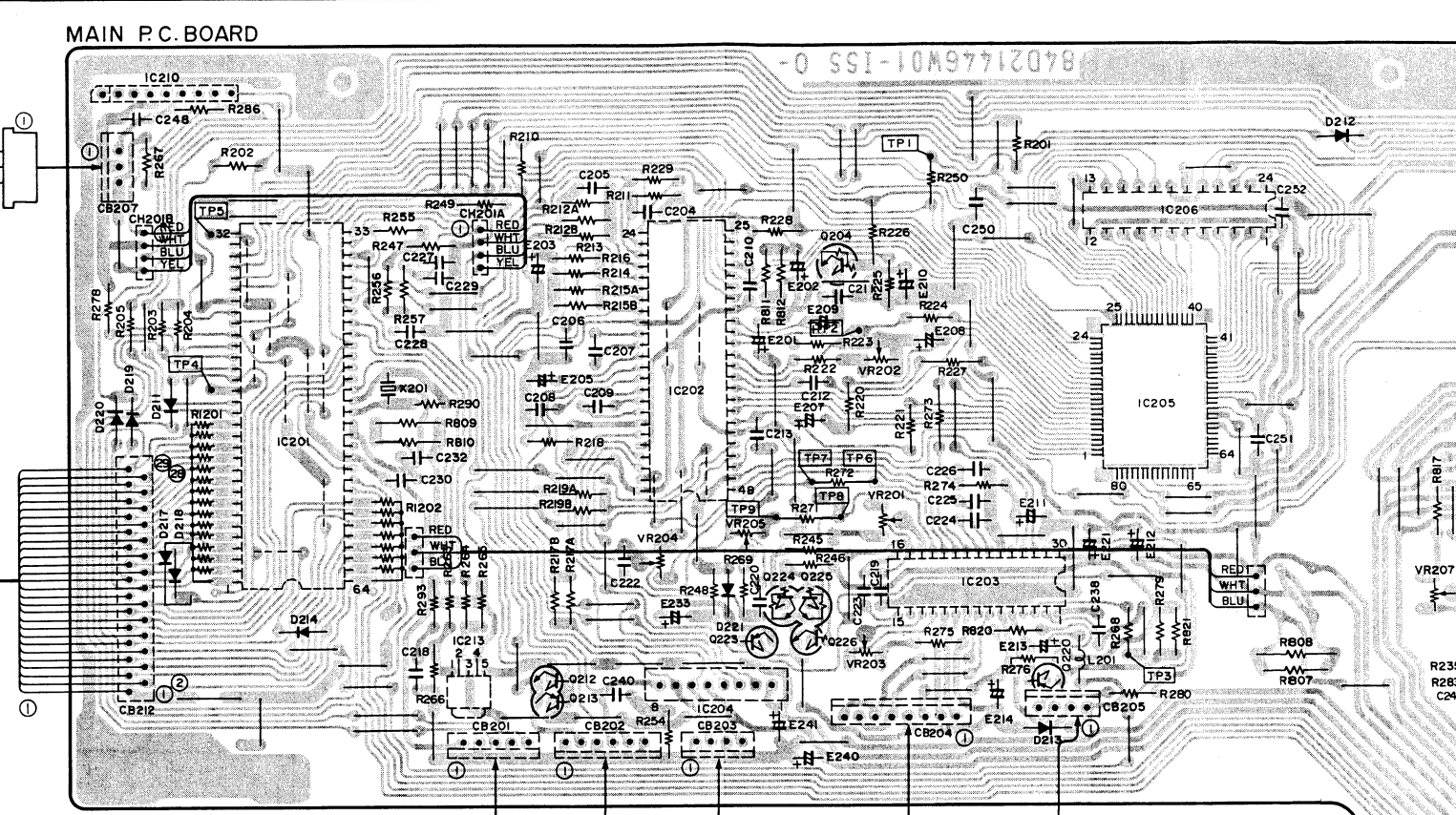
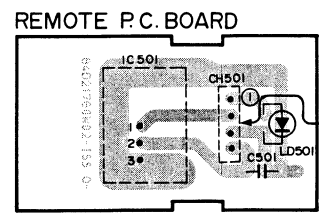
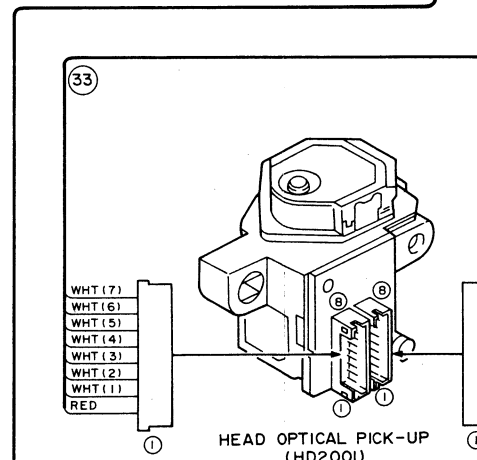
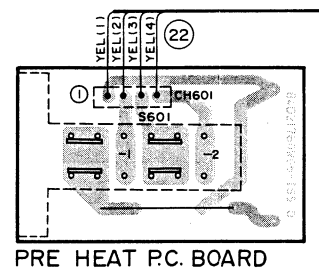
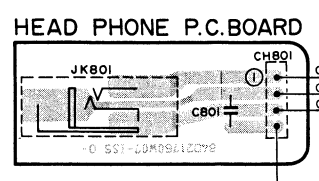
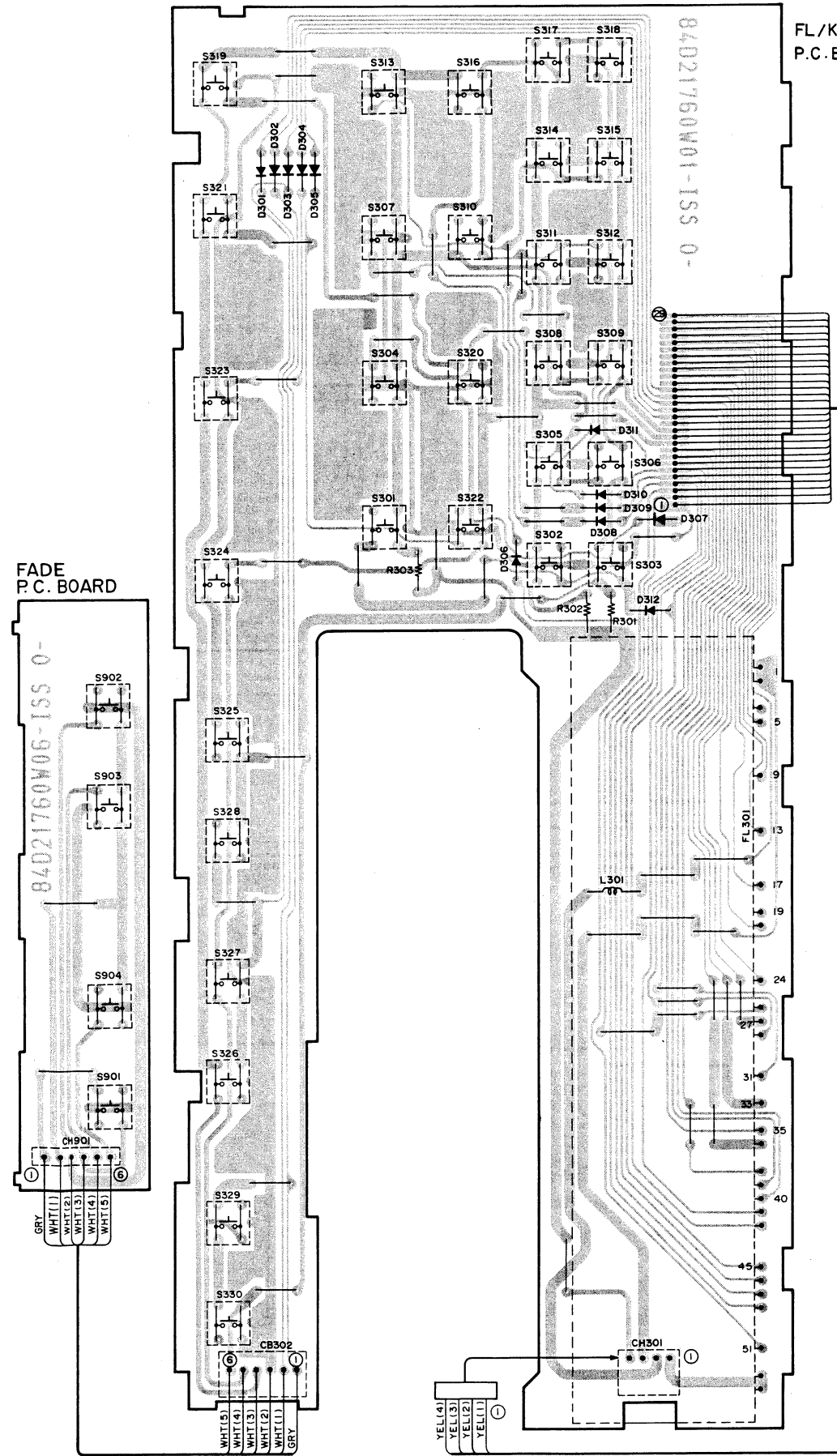

A | B | C | D | E | F | G | H | I





# Electrical Parts List

Resistor: Carbon resistors under 1/4 watts are not mentioned in the parts list, please confirm them by schematic diagram.

Capacitor:  $\mu$ F=microfarads, pF=picofarads

Abbreviations			
CAP.-Capacitor		CER.-Ceramic	
CP.-Chip		ELY.-Electrolytic	
LED.-Light Emitting Diode		MIC.-Mica	
MO.-Metal Oxide Film		MYL.-Mylar	
PP.-Polypropylene		SOL.-Solid	
TAN.-Tantalum		ZEN.-Zener	

Symbol No.	Part No.	Description		
<b>Main P.C. Board</b>				
<b>IC's</b>				
IC201	51T15749W02	15749W02		
IC202	51T84722F02	CXA1082BS		
IC203	51T84721F02	CXA1081S		
IC204	51T25098W01	STA341M		
IC205	51T84720F01	CXD1125QZ		
or	51T84719F01	CXD1135QZ		
IC206	51T84723F01	LC3516AS		
IC209	51T15628W01	SM5813AP		
IC210	51T62866F01	NJM2903S		
IC211	51T15956W01	AD1860		
IC212	51T15956W01	AD1860		
IC213	51T90889F01	LA6501LR		
IC214	51T80339F01	NJM7905FA		
IC215	51T16168W02	$\mu$ PC2405HF		
IC216	51T80338F01	NJM7805FA		
IC217	51T80339F01	NJM7905FA		
IC218	51T90889F01	LA6501LR		
<b>Transistors</b>				
Q204	48T82763F00	DTC114EL		
Q205	48T82762F02	DTA114EL		
Q206	48T82762F02	DTA114EL		
Q207	48T82763F02	DTC114EL		
Q208	48T82763F02	DTC114EL		
Q209	48T82763F02	DTC114EL		
Q210	48T82758F01	2SC4038		
Q211	48T82758F01	2SC4038		
Q212	48T69176F01	2SC3421		
Q213	48T69177F01	2SA1358		
Q220	48T82759F01	2SB1277		
Q221	48T57305F04	2SD1302		
or	48T90183F04	2SD1996		
Q222	48T57305F04	2SD1302		
or	48T90183F04	2SD1996		

Symbol No.	Part No.	Description		
Q223	48T43526F02	2SA950		
Q224	48T62963F04	DTC114		
Q225	48T62963F04	DTC114		
Q226	48T62963F11	DTC124TA		
<b>Diodes</b>				
D201	48S40477U01	1N4003		
D202	48S40477U01	1N4003		
D203	48S40477U01	1N4003		
D204	48S40477U01	1N4003		
D206	48T84758F01	1SS270A		
D207	48T84758F01	1SS270A		
D208	48S40477U01	1N4003		
D209	48S40477U01	1N4003		
D210	48S40477U01	1N4003		
D211	48T84758F01	1SS270A		
D212	48T84758F01	1SS270A		
D213	48T84758F01	1SS270A		
D214	48T84758F01	1SS270A		
D215	48T84758F01	1SS270A		
D216	48S40477U01	1N4003		
D217	48T84758F01	1SS270A		
D218	48T84758F01	1SS270A		
D219	48T84758F01	1SS270A		
D220	48T84758F01	1SS270A		
D221	48T84758F01	1SS270A		
D222	48T84758F01	1SS270A		
D223	48T84758F01	1SS270A		
<b>Capacitors</b>				
● C201	08T57298F01	CER..	0.1 $\mu$ F	
E201	23T00180L08	ELY..	33 $\mu$ F/16V	
● C202	08T57298F01	CER..	0.1 $\mu$ F	
E202	23T00180L08	ELY..	33 $\mu$ F/16V	
E203	23T00180L25	ELY..	10 $\mu$ F/50V	
C204	08T57705F67	MYL..	0.01 $\mu$ F	
C205	08T57705F69	MYL..	0.015 $\mu$ F	
E205	23T00180L25	ELY..	10 $\mu$ F/50V	
C206	08T90316F27	TF..	0.068 $\mu$ F	
C207	08T90316F29	TF..	0.1 $\mu$ F	
E207	23T00180L20	ELY..	0.47 $\mu$ F/50V	
C208	08T57705F73	MYL..	0.033 $\mu$ F	
E208	23T00180L13	ELY..	47 $\mu$ F/25V	
C209	08T90316F29	TF..	0.1 $\mu$ F	
E209	23T00180L24	ELY..	4.7 $\mu$ F/50V	

Note: ● : For West Germany model only (AD) Others ; Common

▲ : For Japanese model only (JA)



Symbol No.	Part No.	Description		
C210	08T57851F13	TF.. 0.1 $\mu$ F		
E210	23T00180L21	ELY.. 1 $\mu$ F/50V		
C211	08T57705F63	MYL.. 4700pF		
E211	23T00180L20	ELY.. 0.47 $\mu$ F/50V		
C212	08T57705F55	MYL.. 1000pF		
E212	23T00180L26	ELY.. 22 $\mu$ F/50V		
C213	08T57705F67	MYL.. 0.01 $\mu$ F		
E213	23T00180L28	ELY.. 47 $\mu$ F/50V		
C214	08S65480F13	CER.. 10pF		
E214	23T00180L26	ELY.. 22 $\mu$ F/50V		
C215	08S65480F13	CER.. 10pF		
E215	23T00180L08	ELY.. 33 $\mu$ F/16V		
C218	08T90316F29	TF.. 0.1 $\mu$ F		
C219	08T25620W01	CER.. 0.47 $\mu$ F		
C220	08T57705F59	MYL.. 2200pF		
E221	23T00180L26	ELY.. 22 $\mu$ F/50V		
C222	08T57705F63	MYL.. 4700pF		
C223	08T57705F73	MYL.. 0.033 $\mu$ F		
C224	08T57705F67	MYL.. 0.01 $\mu$ F		
C225	08T57705F67	MYL.. 0.01 $\mu$ F		
C226	08T57705F67	MYL.. 0.01 $\mu$ F		
E226	23T00181L21	ELY.. 1000 $\mu$ F/16V		
C227	08T57705F73	MYL.. 0.033 $\mu$ F		
E227	23T00180L25	ELY.. 10 $\mu$ F/50V		
C228	08T57705F69	MYL.. 0.015 $\mu$ F		
E228	23T00180L22	ELY.. 2.2 $\mu$ F/50V		
C229	08T57705F65	MYL.. 6800pF		
E229	23T00180L21	ELY.. 1 $\mu$ F/50V		
C230	08T25620W01	CER.. 0.47 $\mu$ F		
E231	23T00024L11	ELY.. 2200 $\mu$ F/50V		
C232	08T25620W01	CER.. 0.47 $\mu$ F		
E232	23T00024L11	ELY.. 2200 $\mu$ F/50V		
E233	23T00180L21	ELY.. 1 $\mu$ F/50V		
● C233	08T25620W01	CER.. 0.47 $\mu$ F		
● C234	21S40655F19	CER.. 47pF		
● C235	08T57298F01	CER.. 0.1 $\mu$ F		
E235	23T00207L01	ELY.. 100 $\mu$ F/50V		
● C236	08T40794F50	CER.. 1000pF		
E236	23T00207L01	ELY.. 100 $\mu$ F/50V		
● C237	08T57298F01	CER.. 0.1 $\mu$ F		
E237	23T00181L48	ELY.. 100 $\mu$ F/50V		
C238	08T57705F59	MYL.. 2200pF		
E238	23T00181L48	ELY.. 100 $\mu$ F/50V		
C240	08T90316F29	TF.. 0.1 $\mu$ F		
E240	23T00180L08	ELY.. 33 $\mu$ F/16V		

Symbol No.	Part No.	Description		
C241	08T00151L73	PP.. 9100P		
E241	23T00180L08	ELY.. 33 $\mu$ F/16V		
C242	08T00151L73	PP.. 9100p		
C243	08T25620W01	CER.. 0.47 $\mu$ F		
C244	08T25620W01	CER.. 0.47 $\mu$ F		
C247	08T57298F01	CER.. 0.1 $\mu$ F		
● E247	23T00180L25	ELY.. 10 $\mu$ F/50V		
C248	08T57298F01	CER.. 0.1 $\mu$ F		
● E248	23T00180L25	ELY.. 10 $\mu$ F/50V		
● E249	23T00180L25	ELY.. 10 $\mu$ F/50V		
C250	08T25620W01	CER.. 0.47 $\mu$ F		
● E250	23T00180L25	ELY.. 10 $\mu$ F/50V		
C251	08T25620W01	CER.. 0.47 $\mu$ F		
C252	08T25620W01	CER.. 0.47 $\mu$ F		
● C253	08T25620W01	CER.. 0.47 $\mu$ F		
● E257	23T00180L25	ELY.. 10 $\mu$ F/50V		
● E258	23T00180L25	ELY.. 10 $\mu$ F/50V		
Resistors				
R808	06T92264F19	MF.. 56 ohm 2W		
VR201	18T15355W15	Volume, RH064AC 22K ohm		
VR202	18T15355W09	Volume, RH064AC 2.2K ohm		
VR203	18T15335W15	Volume, RH064AC 22K ohm		
VR204	18T15335W15	Volume, RH064AC 22K ohm		
VR205	18T15335W15	Volume, RH064AC 22K ohm		
VR207	18T15355W19	Volume, RH074AC 100K ohm		
VR208	18T15355W19	Volume, RH074AC 100K ohm		
R1201	06T74182F09	Res.. Block 270K ohm x15		
R1202	06T74182F08	Res.. Block 270K ohm x8		
Coil				
L201	24T70381F21	COIL. IND. 10 $\mu$ H		
Jack				
● JK201	09T84214F01	Head Phone Mini		
● S201				

Note: ● ; For West Germany model only (AD) Others : Common

▲ : For Japanese model only (JA)

Symbol No.	Part No.	Description		
<b>Crystals</b>				
X201	91T15285W01	CER. LOCK 4.19MHz		
X202	91T84727F02	AT-51 16.9344MHz		
<b>Power Supply P.C. Board</b>				
<b>IC's</b>				
IC101	51T81896F01	M5216P		
IC102	51T25576W01	NJM4580DD		
IC105	51T16168W01	$\mu$ PC2412HF		
<b>Transistors</b>				
Q101	48T69177F01	2SA1358		
Q102	48T71447F01	2SC2752		
Q103	48T57305F04	2SD1302		
or	48T90183F04	2SD1996		
▲ Q104	48T69176F01	2SC3421		
● Q104	48T57305F04	2SD1302		
● or	48T90183F04	2SD1994		
Q105	48T57305F04	2SD1302		
or	48T90183F04	2SD1996		
Q106	48T57305F02	2SD1302		
or	48T90183F04	2SD1996		
Q107	48T57305F04	2SD1302		
or	48T90183F04	2SD1996		
Q108	48T57305F04	2SD1302		
or	48T90183F04	2SD1996		
<b>Diodes</b>				
D101	48S40477U01	1N4003		
D102	48S40477U07	1N4007		
D103	48T84758F01	1SS270A		
D104	48T84758F01	1SS270A		
D105	48S40477U01	1N4003		
D106	48S40477U01	1N4003		
D107	48S40477U01	1N4003		
D108	48S40477U01	1N4003		
D110	48T84758F01	1SS270A		
D111	48T84758F01	1SS270A		
D112	48T84758F01	1SS270A		
D113	48T84758F01	1SS270A		
D114	48T84758F01	1SS270A		
D115	48T84758F01	1SS270A		
● D116	48T84758F01	1SS270A		

Note: ● : For West Germany model only (AD) Others : Common

▲ : For Japanese model only (JA)

Symbol No.	Part No.	Description		
● D117	48T84758F01	1SS270A		
● D118	48T84758F01	1SS270A		
● D119	48T84758F01	1SS270A		
▲ ZD101	48T52741F71	ZEN., HZ33-2L		
● ZD101	48T83128F71	ZEN., HZS33-2L		
ZD102	48T83128F65	ZEN., HZS27-2L		
<b>Capacitors</b>				
● C101	08T00196L01	XE.. 0.01 $\mu$ F		
E101	23T00181L82	ELY.. 100 $\mu$ F/ 250V		
● C102	08T00196L01	XE.. 0.01 $\mu$ F		
E102	23T00181L32	ELY.. 3300 $\mu$ F/25V		
C103	08T90316F29	TF.. 0.1 $\mu$ F		
E103	23T00132L27	ELY.. 100 $\mu$ F/50V		
▲ C104	08T25620W01	CER.. 0.47 $\mu$ F		
● C104	23T00181L39	ELY.. 0.47 $\mu$ F/ 100V		
E104	23T00181L82	ELY.. 100 $\mu$ F/ 250V		
● C107	08T00125L02	PLY.. 4700pF		
E107	23T00181L81	ELY.. 33 $\mu$ F/ 250V		
▲ C108	08T25620W01	CER.. 0.47 $\mu$ F		
● C108	23T00181L39	ELY.. 0.47 $\mu$ F/ 100V		
E108	23T00181L81	ELY.. 33 $\mu$ F/ 250V		
▲ C109	08T25620W01	CER.. 0.47 $\mu$ F		
● C109	23T00181L39	ELY.. 0.47 $\mu$ F/ 100V		
E109	23T00180L23	ELY.. 3.3 $\mu$ F/50V		
● C110	08T00151L13	PP.. 1000pF		
● C111	08T00151L13	PP.. 1000pF		
● C112	08T00151L12	PP.. 820pF		
● C113	08T00151L12	PP.. 820pF		
<b>Resistors</b>				
▲ R121	06T92264F18	MF.. 51 ohm 2W		
R123	06T00147L53	FC.. 330 ohm 1/2W		
R124	06T00147L53	FC.. 330 ohm 1/2W		
VR101	18T10803W02	Volume, RK16313MA		
M101	18T10803W02	Volume, RK16313MA		
<b>Relay</b>				
▲ RL101	80T92812F02	MR62-5SR		

Symbol No.	Part No.	Description		
<b>Coil</b>				
● L101	24T82315F01	Filter. Line FKOB160MH02		
<b>Switch</b>				
S101	40T15820W01	PUSH POWER		
<b>Jacks</b>				
JK101	09T15974W01	2P. T6302-D105U (OUT-VARIABLE)		
JK102	09T15974W01	2P. T6302-D105U (OUT-FIXED)		
<b>FL/Key SW P.C. Board</b>				
<b>Diodes</b>				
D301	48T84758F01	1SS270A		
D302	48T84758F01	1SS270A		
D303	48T84758F01	1SS270A		
D304	48T84758F01	1SS270A		
D305	48T84758F01	1SS270A		
D306	48T84758F01	1SS270A		
D307	48T84758F01	1SS270A		
D308	48T84758F01	1SS270A		
D309	48T84758F01	1SS270A		
D310	48T84758F01	1SS270A		
D311	48T84758F01	1SS270A		
D312	48T84758F01	1SS270A		
<b>Switches</b>				
S301	40T83324F11	TACT SKHHAP(Repeat)		
S302	40T83324F11	TACT SKHHAP(6)		
S303	40T83324F11	TACT SKHHAP(0)		
S304	40T83324F11	TACT SKHHAP(A-Pause)		
S305	40T83324F11	TACT SKHHAP(7)		
S306	40T83324F11	TACT SKHHAP(1)		
S307	40T83324F11	TACT SKHHAP(A-Scan)		
S308	40T83324F11	TACT SKHHAP(8)		
S309	40T83324F11	TACT SKHHAP(2)		
S310	40T83324F11	TACT SKHHAP(M-Check)		
S311	40T83324F11	TACT SKHHAP(9)		
S312	40T83324F11	TACT SKHHAP(3)		
S313	40T83324F11	TACT SKHHAP(Random)		
S314	40T83324F11	TACT SKHHAP(10)		
S315	40T83324F11	TACT SKHHAP(4)		

Note: ● : For West Germany model only(AD) Others ; Common  
▲ : For Japanese model only(JA)

Symbol No.	Part No.	Description		
S316	40T83324F11	TACT SKHHAP(Edit)		
S317	40T83324F11	TACT SKHHAP(+10)		
S318	40T83324F11	TACT SKHHAP(5)		
S319	40T83324F11	TACT SKHHAP(STOP)		
S320	40T83324F11	TACT SKHHAP(Clear)		
S321	40T83324F11	TACT SKHHAP(PAUSE)		
S322	40T83324F11	TACT SKHHAP(Program)		
S323	40T83324F11	TACT SKHHAP(PLAY)		
S324	40T83324F11	TACT SKHHAP(Open/Close)		
S325	40T83324F11	TACT SKHHAP(SKIP-up)		
S326	40T83324F11	TACT SKHHAP(BACKWARD)		
S327	40T83324F11	TACT SKHHAP(FORWARD)		
S328	40T83324F11	TACT SKHHAP(SKIP-down)		
S329	40T83324F11	TACT SKHHAP (Display-adjust)		
S330	40T83324F11	TACT SKHHAP(T-display)		
<b>Fade P.C. Board</b>				
<b>Switches</b>				
S901	40T83324F11	TACT SKHHAP (Time fade out)		
S902	40T83324F11	TACT SKHHAP(VOLUME-down)		
S903	40T83324F11	TACT SKHHAP(VOLUME-Up)		
S904	40T83324F11	TACT SKHHAP(Fadeout)		
<b>Coil</b>				
▲ L301	24T50508F46	Ind 1mH		
● L302	24T35072W01	FBI. BLO1RN1-A92T5		
<b>Remote P.C. Board</b>				
<b>IC's</b>				
IC501	51T16094W01	GP 1U521		
or	51T16094W02	GP 1U521X		
<b>Capacitor</b>				
C501	08S65480F63	CER. . . . . 0.1 μF		
<b>LED</b>				
LD501	48T60947F05	SHL-34VR3F (RED)		

Symbol No.	Part No.	Description		
<b>Tube P.C. Board (1)</b>				
Capacitor				
E701	23T00181L69	ELY..	10 $\mu$ H/ 100V	
Resistors				
R705	06T92261F26	MF..	2.4 ohm 2W	
R706	06T92261F26	MF..	2.4 ohm 2W	
<b>Tube P.C. Board (2)</b>				
Capacitors				
▲ C401	08T00151L25	PP..	0.01 $\mu$ F	
● C401	08T00019L01	Mt1..	0.1 $\mu$ F	
▲ C402	08T00151L25	PP..	0.01 $\mu$ F	
● C402	08T00019L01	Mt1..	0.1 $\mu$ F	
▲ C403	08T00151L13	PP..	1000pF	
▲ C404	08T00151L13	PP..	1000pF	
C405	08T00019L01	Mt1..	0.1 $\mu$ F	
C406	08T00019L01	Mt1..	0.1 $\mu$ F	
C407	08T00019L12	MYL..	3.3 $\mu$ F	
C408	08T00019L12	MYL..	3.3 $\mu$ F	
<b>Miscellaneous</b>				
▲ Q701	65T00091L03	Tube, 6CG7GE		
● Q701	65T00091L01	Tube, 6CG7		
▲ Q702	65T00091L03	Tube, 6CG7GE		
● Q702	65T00091L01	Tube, 6CG7		
▲ C107	08T00125L02	Poly..	4700pF	
▲ C801	08T65480F63	CER.,	0.1 $\mu$ F	
● C801	08T57298F01	CER.,	0.1 $\mu$ F	
● C802	08T00151L12	PP..	820pF	
● C803	08T00151L12	PP..	820pF	
JK801	09T66672F04	Head Phone		
S601	40T15685W01	SW. Push(PRE HEAT)		
▲ P101	28T81592F03	Plug. AC Cord		
● P101	28T43812P04	Plug. Cord		
▲ T101	25T25627W01	Trans. Power		
● T101	25T25627W02	Trans. Power		
T103	25T25626W03	Trans. Output		
T104	25T25626W04	Trans. Output		
● F102	65T42077U01	Fuse, Semko 315mA		
FL301	65T15386W01	FL Display FV335G		

Symbol No.	Part No.	Description		
C2001	08S40154T63	Cap.. Cer. 0.022 $\mu$ F		
S2001	40T71025F01	SW.. Detector(CLOSE)		
S2002	40T71025F01	SW.. Detector(OPEN)		
S2003	40T71025F01	SW.. Detector(Limit)		
M2001	01V11200W42	Assy.. Motor Loading		
M2002	59T81431F01	Motor.. Spindle		
M2003	01V81800F61	Assy.. Motor SLED		
HD2001	88T81528F01	Head. Optical Pick Up		

Note: ● : For West Germany model only(AD) Others ; Common

▲ : For Japanese model only(JA)

# Cabinet Assembly Parts List

Note: The parts without part numbers are not supplied.

Symbol No.	IN-dex	Part No.	Description	Symbol No.	IN-dex	Part No.	Description		
▲	1	5-C	01V00305S01	Assy., Front Panel		51	2-C	43T16241W08	Support, PBC
●	1	5-C	01V26100W40	Assy., Front Panel		53	1-F	14S20478W38	Insulator, Cover
	3	4-B	36A11877W01	Konb, Display ADJ		54	3-B	75A67341F01	Cushion, Tube
	4	4-B	36A11877W10	Konb, Push Backward		55	2-H	14S20478W39	Insulator, Cover
	5	2-E	14S20875W35	Insulator, Cover		56	1-B	14S96390F69	Insulator, Cover
	6	3-D	14S20478W20	Insulator, Cover		57	3-B	36A67333F01	Konb, Push
	7	4-C	36A11877W11	Konb, Push Forward		60	1-F	14S96390F70	Insulator, Cover
	8	4-C	36A11877W12	Konb, Skip Down	▲	61	1-D	14S20478W01	Insulator, Cover
	9	5-C	36A11877W13	Konb, Skip Up	●	61	1-D	14S20478W38	Insulator, Cover
	10	5-C	36B11878W02	Konb, Function		62		03S40012G18	Scr., TPG(M2.6x6)
	12		03S82672F33	Scr., Bind(M3x8)		64		75S12196W53	Cushion, Rubber
	13	2-F	15C11879W01	Cover, Top		65	2-B	05B41635J02	Rivet, Push
	14	3-E	29A737272	Lug, Wrap Around		69	4-A	43A41837U05	Spacer, SW
▲	15	4-G	15D11880W05	Cover, Rear		72	2-B	14S96390F58	Insulator, Cover
●	15	4-G	15D11880W06	Cover, Rear		73	2-B	01T84733F11	Assy., Lug Wire
▲	18		03S71252F70	Scr., Cup(M3x10)		74	2-B	03S82671F81	Scr., Bind(M3x6)
●	18		03S71677F41	Scr., W/Washer(3x6)		75	3-D	14S20478W34	Insulator, Cover
	19	4-H	43T92160F04	Spacer, PCB 18R		76		75S12196W54	Cushion, Rubber
	20	3-C	45B57186F01	Lever, Konb		77	3-B	75S12196W21	Cushion, Rubber
	21		29C41045P05	Lug, Wrap Around		80	3-C	14S20478W16	Insulator, Cover
▲	22	2-G	43B41625J05	Stopper, Cord		82	4-F	14S94461F87	Insulator, Cover
●	22	2-G	43B41625J02	Stopper, Cord		83		14S20478W37	Insulator, Cover
	26		03S72235F20	Scr., Bind(M3x8)		84	3-F	14S20875W40	Insulator, Cover
	29	3-B	07A83876F01	Support, FL		85	2-G	14S20478W36	Insulator, Cover
	30	4-F	14S94461F85	Insulator, Cover	●	86	5-B	04S40072G31	Washer, Tooth Lock
	31	3-A	09T64527F02	Socket, Tube 9P	●	87	4-C	09T51410F01	Holder, Fuse
	32	5-F	75A80719F01	Pad, Trannleg	▲	100		75A21814W01	Cushion, Wood Cab
	33	5-F	75B80720F03	Trannleg	▲	101	5-K	16B21554W03	Cab., Wood "R"
	34	5-F	75A13129W02	Pad, Trannleg	▲	102	3-H	16B21554W04	Cab., Wood "L"
	35	4-A	36A67330F01	Konb, Power	▲	103		03A92739F02	Scr., Wood Cab(M4x25)
	36	4-B	75S72374F91	Cushion, Rubber	●	103		03S40036U01	Scr., W/Washer(M4x8)
	38		03S44205G50	Scr., Countersink (M3x6)	●	104	1-G	14A38009W01	Insulator, Cover
	39		03S71677F30	Scr., Bind(M4x12)					
	40		13A13279W01	ESC, Scr(N)					
	41		03S52360F36	Scr., Bind(M4x8)					
	42	3-D	03S44205G92	Scr., Bind(M4x6)					
	43	2-D	64B11870W03	Tray, Panel					
	44	3-E	14S94461F88	Insulator, Cover					
	45		75S12196W27	Cushion, Rubber					
▲	46	3-E	14S20478W35	Insulator, Cover					
●	46	3-E	14S20478W53	Insulator, Cover					
	47	3-E	14S20875W39	Insulator, Cover					
	48		03S71677F06	Scr., Flange(M2.6x6)					
	49		03S44205G85	Scr., Bind(M3x8)					
	50	3-C	30T15818W01	Wire, Parallel 29P					

NOTE: ● ; For West Germany model only(AD) Others ; Common

▲ ; For Japanese model only(JA)

# Exploded View (Cabinet)

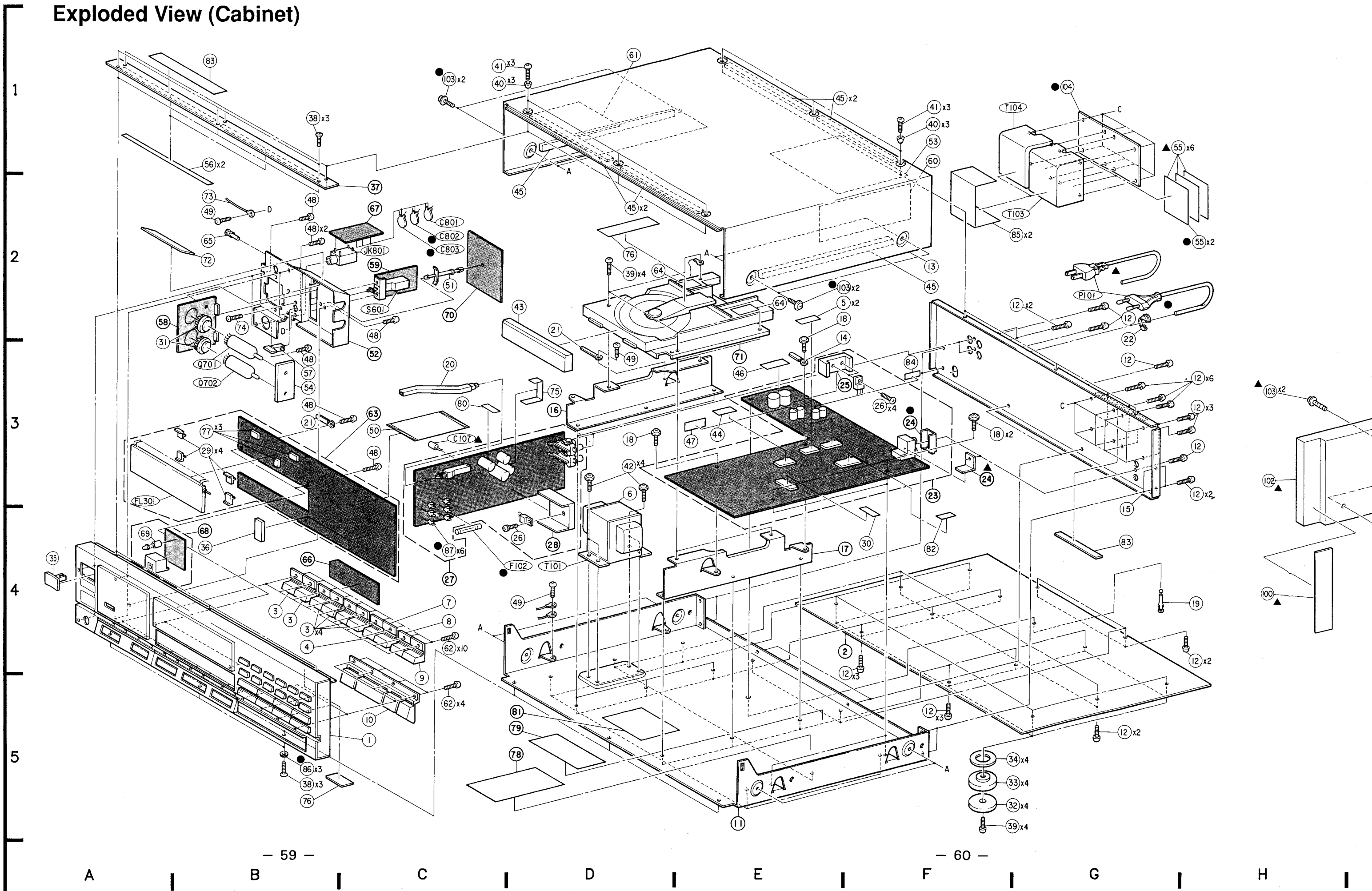

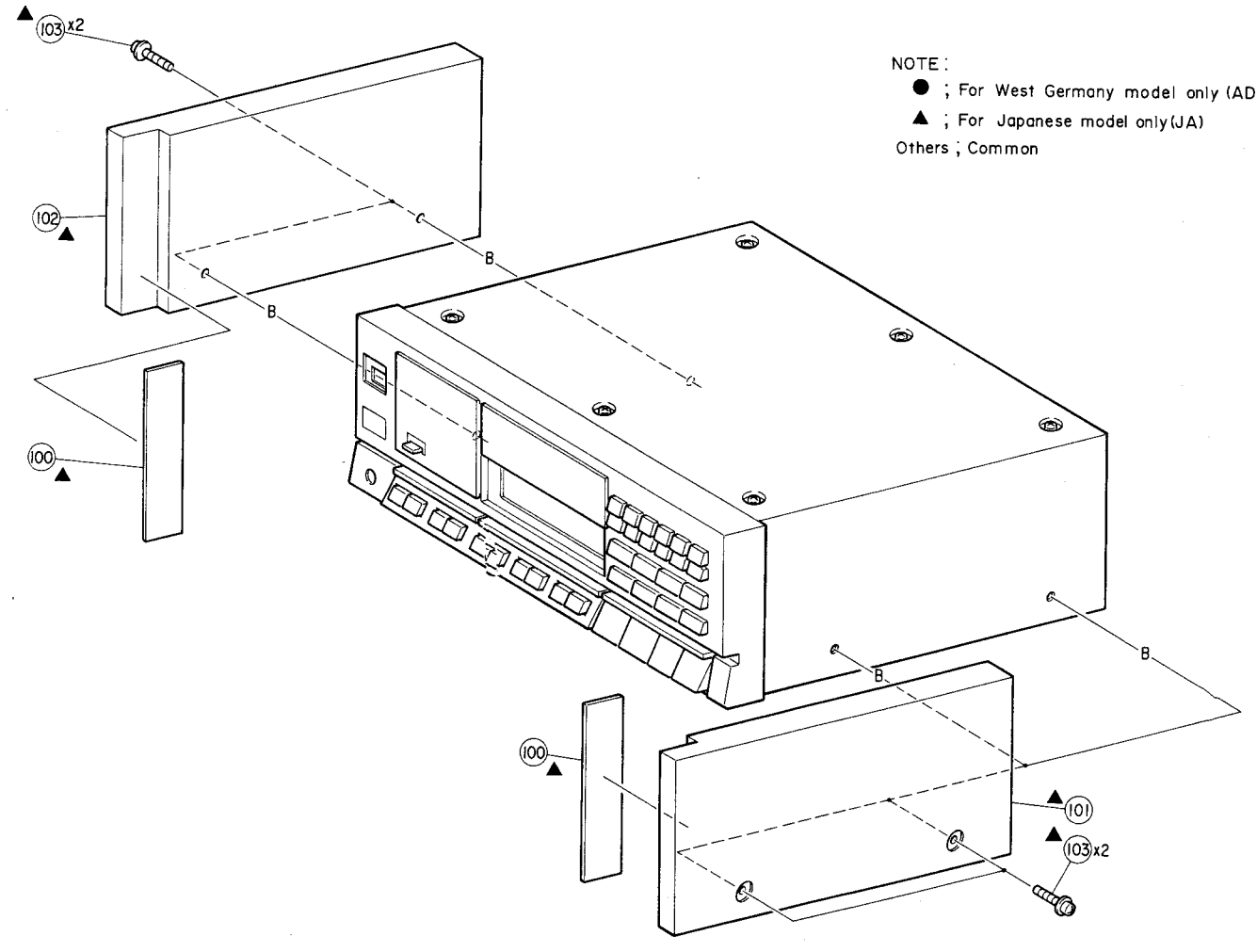
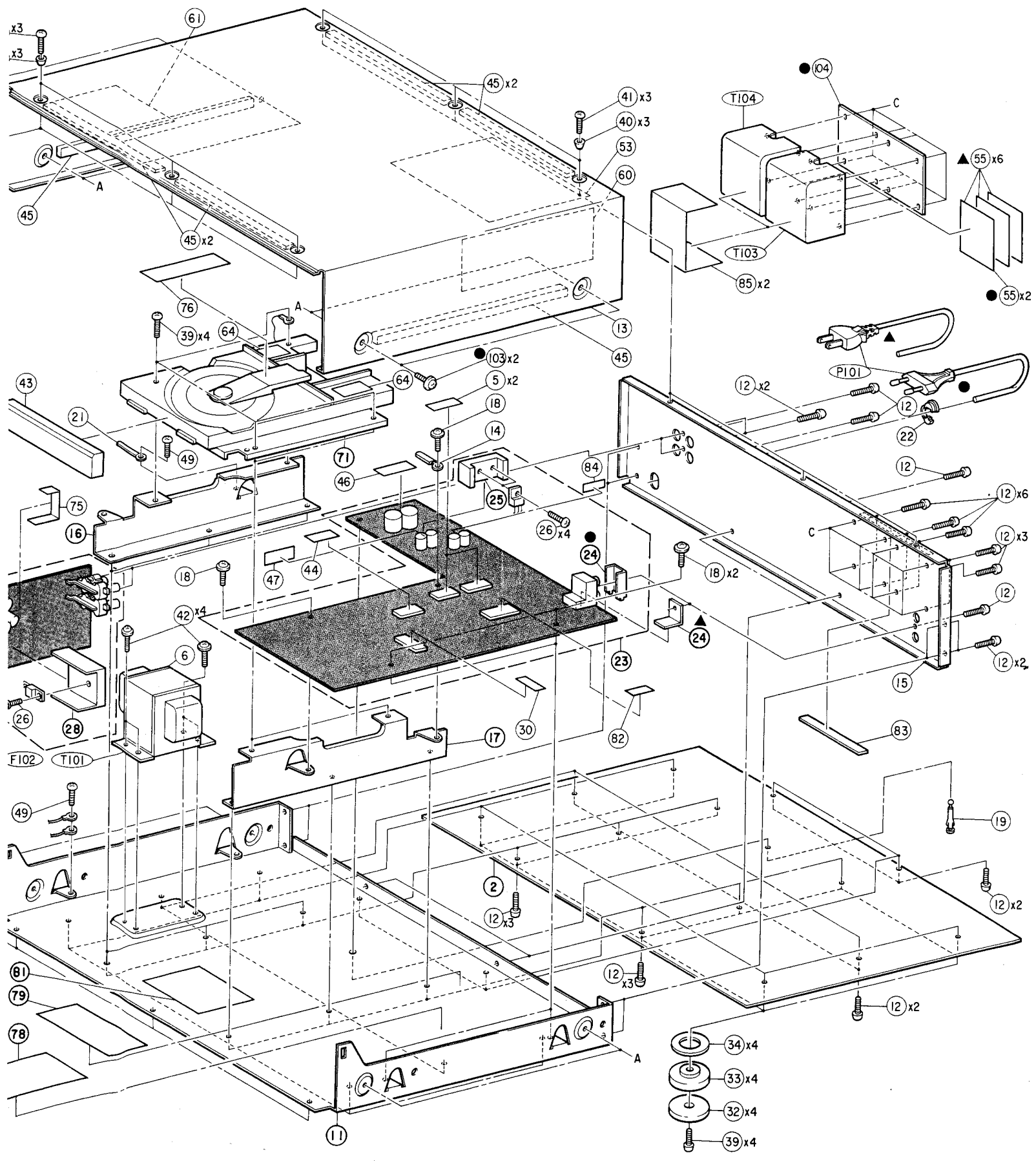

NOTE:  
 ● ; For West Germany model only (AD)  
 ▲ ; For Japanese model only (JA)  
 Others ; Common

# Exploded View (Mechanism)

# Mechanism

Note: The parts with

Symbol No.	IN-dex	Part No.
1	4-C	01C823191
2	2-C	42A814271
3		43A814071
4		75A814111
5	3-G	41A814281
6	4-G	41A814281
7		03S400121
8	2-C	03D400141
9	4-D	45A814341
12	2-G	03S442051
13	2-C	75S121961
14	3-F	44A814011
15	3-F	04A413451
16	4-E	49B814141
17	2-F	03D400141
19	2-D	47A814261
20	2-D	47A814261
23	3-F	03S704941
24	4-E	03D400141
25	2-F	43A411821
26	4-C	01C107161
28	2-B	45C814181
29	3-A	07A814131
30	3-B	49A814031
31	3-A	59T814301
32	2-B	41B814291
33	3-A	03S704941
34	2-C	01T924831
35	3-E	01A823231
36	3-D	49B814171
37	4-D	41A814281
38	2-G	01T847331

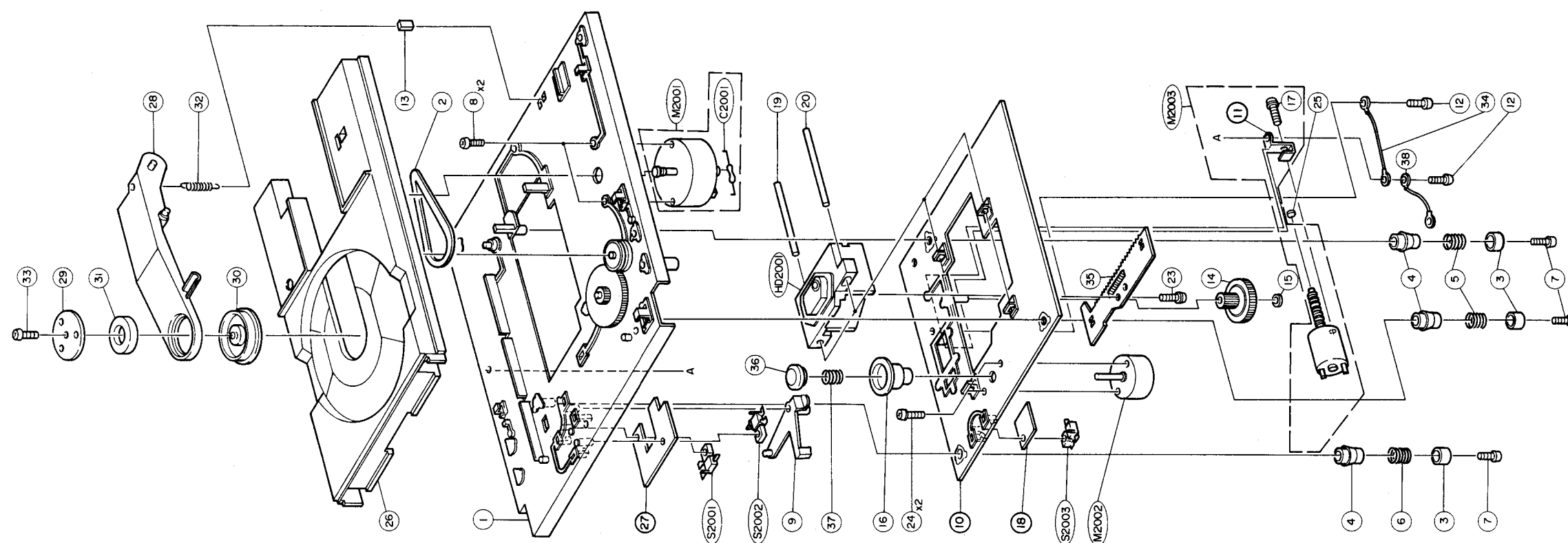



### Mechanism Assembly Parts List

Note: The parts without part numbers are not supplied.

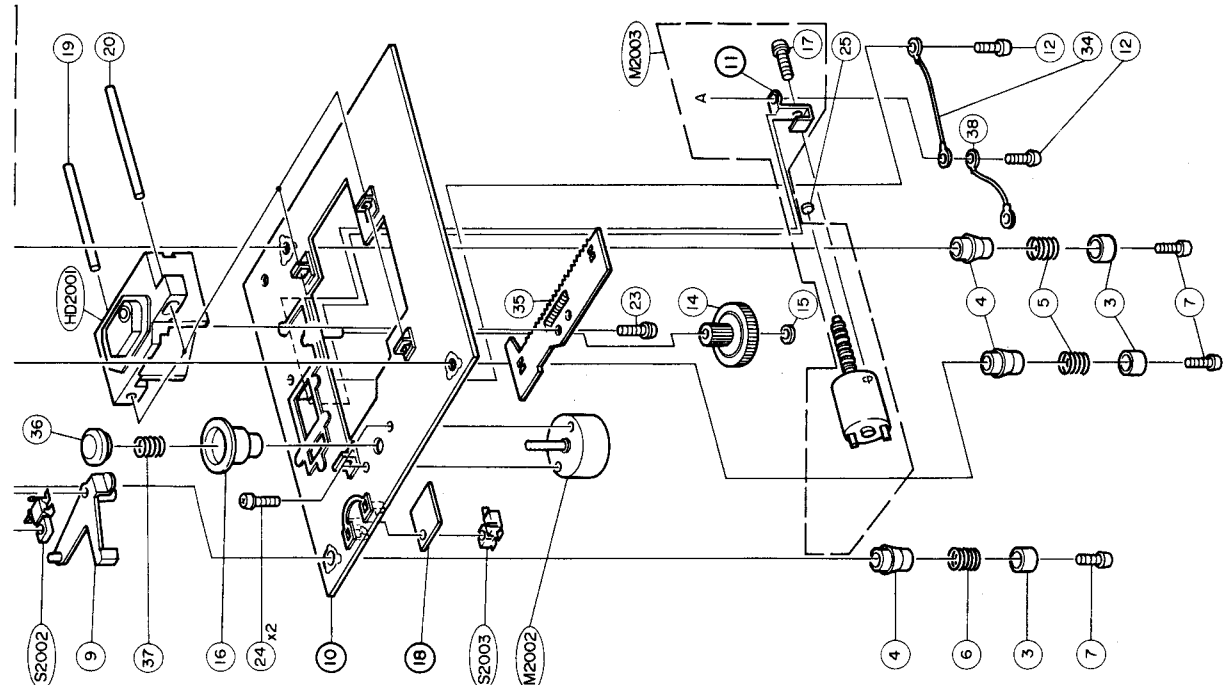

Symbol No.	IN-dex	Part No.	Description	Symbol No.	IN-dex	Part No.	Description
1	4-C	01C82819F01	Assy.. Chas. Main				
2	2-C	42A81427F02	Belt, Drive				
3		43A81407F01	Bush, Damper				
4		75A81411F01	Rubber, Damper				
5	3-G	41A81428F03	Spring, Compression				
6	4-G	41A81428F05	Spring, Compression				
7		03S40012G18	Scr.. Tpg(M2.6X6)				
8	2-C	03D40014G19	Scr.. W/Washer (M2.6x5)				
9	4-D	45A81434F01	Arm, SW				
12	2-G	03S44205G30	Scr.. Pan(M2.6x4)				
13	2-C	75S12196W06	Cushion, Rubber				
14	3-F	44A81401F01	Gear, Worm Wheel				
15	3-F	04A41345F02	Washer, Lock(M1.7)				
16	4-E	49B81414F01	Disc, Table				
17	2-F	03D40014G61	Scr.. W/Washer(M2x5)				
19	2-D	47A81426F01	Shaft, Head				
20	2-D	47A81426F02	Shaft, Head				
23	3-F	03S70494F01	Scr.. Bind(M2x5)				
24	4-E	03D40014G07	Scr.. W/Washer(M2x4)				
25	2-F	43A41182P02	Ball, Steel				
26	4-C	01C10716W01	Assy.. Tray Disc				
28	2-B	45C81418F04	Arm, Clamp				
29	3-A	07A81413F01	Bkt.. Magnet				
30	3-B	49A81403F01	Wheel, Clamp				
31	3-A	59T81430F01	Magnet				
32	2-B	41B81429F02	Spring, Extension				
33	3-A	03S70494F08	Scr.. Pan(M2x5)				
34	2-G	01T92483F01	Assy.. Lug Wire 1P				
35	3-E	01A82323F01	Assy.. Rack				
36	3-D	49B81417F01	Disc, Guide				
37	4-D	41A81428F01	Spring, Compression				
38	2-G	01T84733F11	Assy.. Lug Wire				

## Packing Assembly Parts List

Symbol No.	Part No.	Description		
▲	201-1	68P69552F86	Owner's Manual	
●	201-1	68P96552F89	Owner's Manual	
▲	201-2	01T25754W01	Unit. Remocon	
●	201-2	01T25754W02	Unit. Remocon	
	201-3	60T58064F01	Battery. SUM-3	
	201-4	28T67347F04	Plug. Output	
●	201-5	01T82091F01	Assy., Mini. Plug Cord	
▲	202	56S10005W58	Carton. Packing	
●	202	56S10005W59	Carton. Packing	
	203	56B40442T08	Packing. Front Frame	
	204	56D11887W01	Tray. Pkg	
	205	56B40230G08	Sack. Poly	
▲	206	56A52079F12	Packing. Sheet	
▲	207	56A22487W01	Pad. Packing	
●	207	56A22487W02	Pad. Packing	
	208	56A22665W01	Pad. Packing	

NOTE: ● : For West Germany model only (AD) Others ; Common  
 ▲ : For Japanese model only (JA)

## Packing Method View

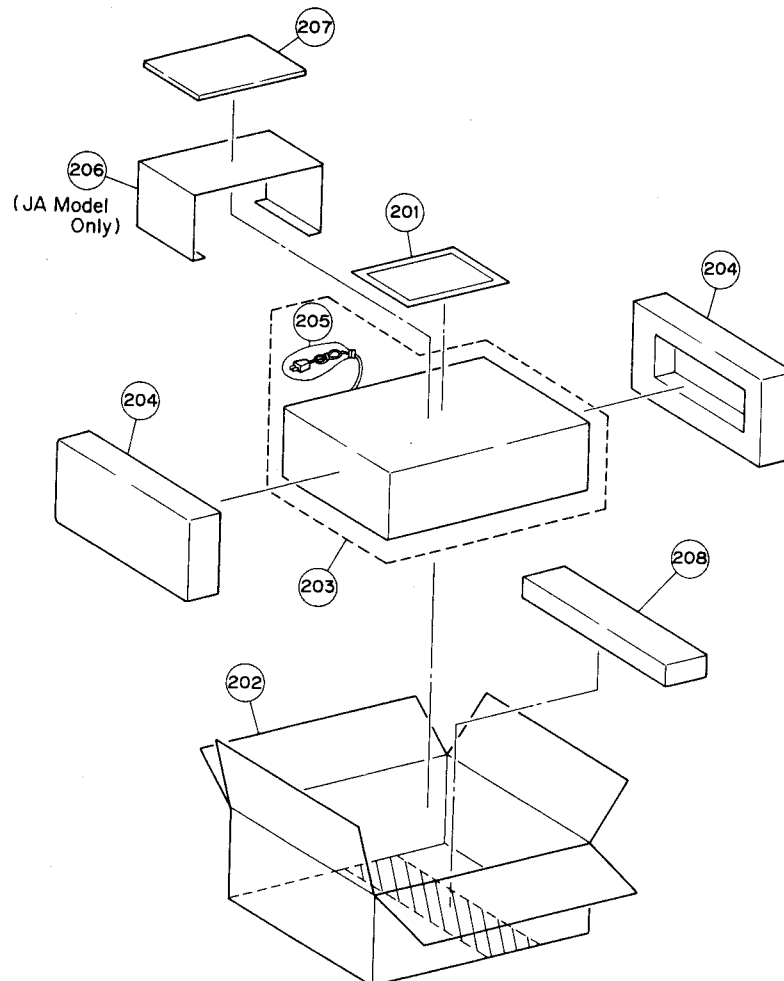

# Semi-Conductor Lead Identifications

M5216P: IC101

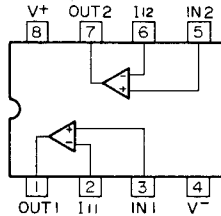
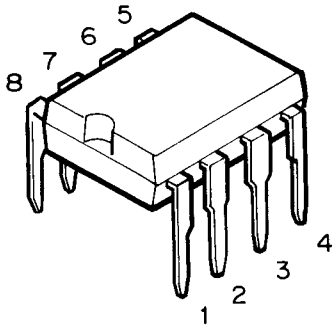

NJM4558DD: IC102

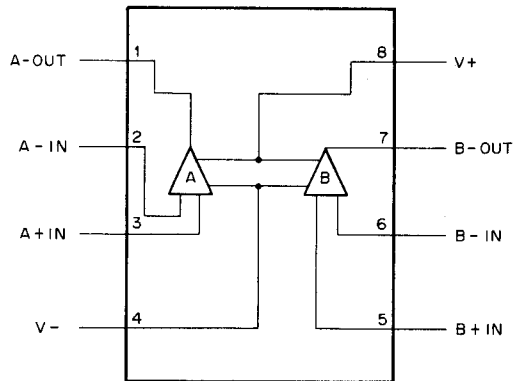
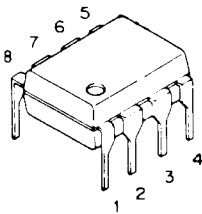

$\mu$ PC2412HF: IC105  
 $\mu$ PC2405HF: IC215

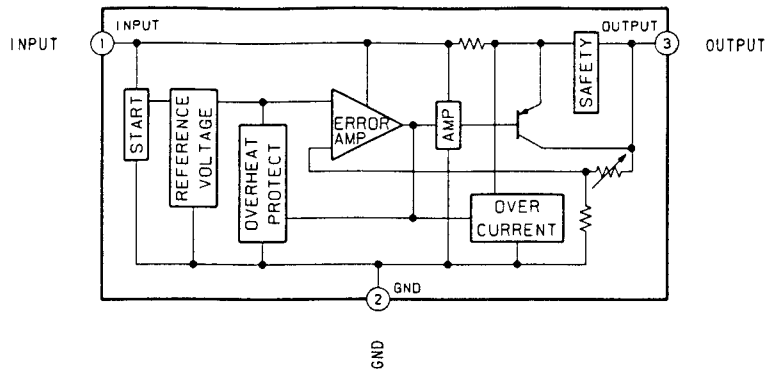
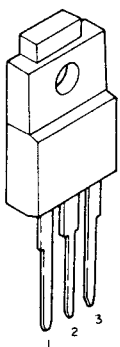

15749W02: IC201

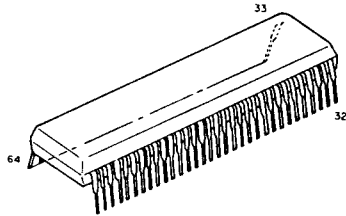

1	SEG4	17	EMPHA	33	SQ CK	49	OSC
2	SEG3	18	GFS	34	SUBQ	50	GND
3	SEG2	19	-35V	35	FOK	51	GND
4	SEG1	20	A.MUTE	36	PWM	52	NC
5	SEG0	21	CLOSE SW	37	SENS	53	+5V
6	DIG0(1G)	22	OPEN SW	38	NC	54	VOL CP
7	DIG1(2G)	23	LD ON	39	MUTE	55	VOL UP
8	DIG2(3G)	24	XRST	40	RHT SW	56	VOL DOWN
9	DIG3(4G)	25	XLT	41	CLOSE	57	SEG12
10	DIG4(5G)	26	DATA	42	OPEN	58	SEG11
11	DIG5(6G)	27	CLK	43	SWRTN	59	SEG10
12	DIG6(7G)	28	POWER	44	KRTN2	60	SEG9
13	DIG7(8G)	29	SCOR	45	KRTN1	61	SEG8
14	DIG8(9G)	30	RMC	46	KRTN0	62	SEG7
15	DIG9(10G)	31	NC	47	RESET	63	SEG6
16	DIMM	32	+5V	48	OSC	64	SEG5

CXA1082BS: IC202

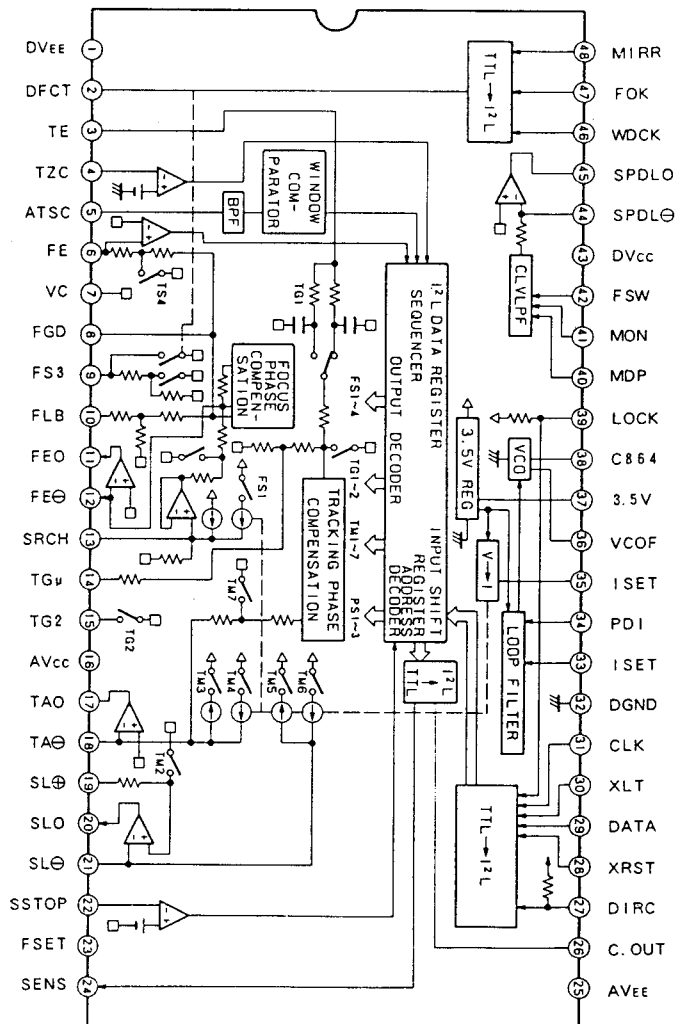
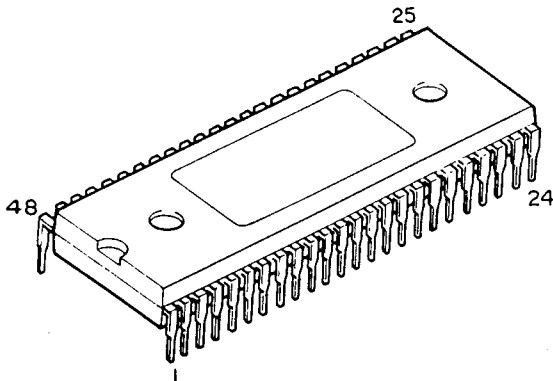

**CXA1081S: IC203**

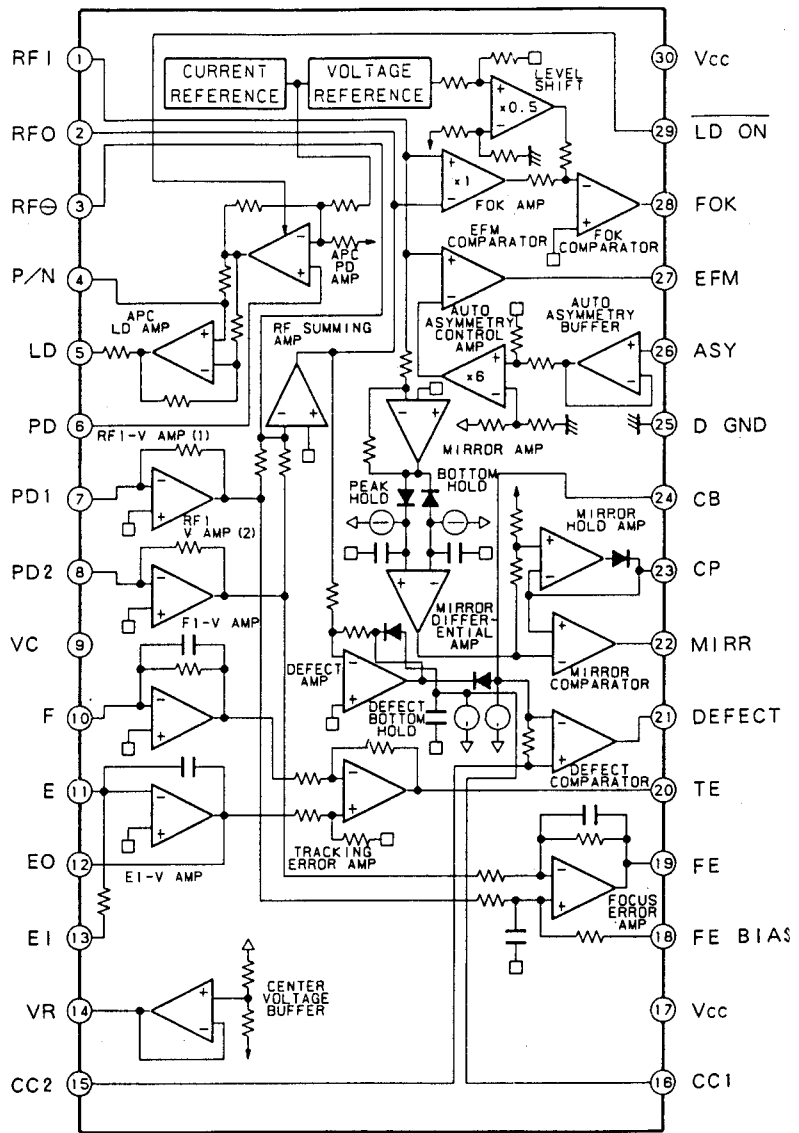
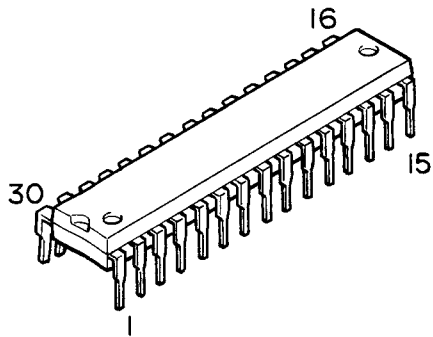

**STA341M: IC204**

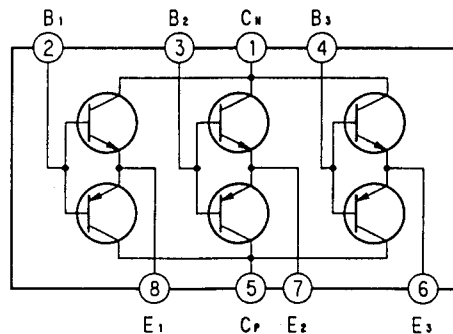
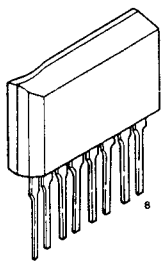

B. Base  
C. Collector  
E. Emitter

CDX1125QZ: IC205  
or CDX1135QZ

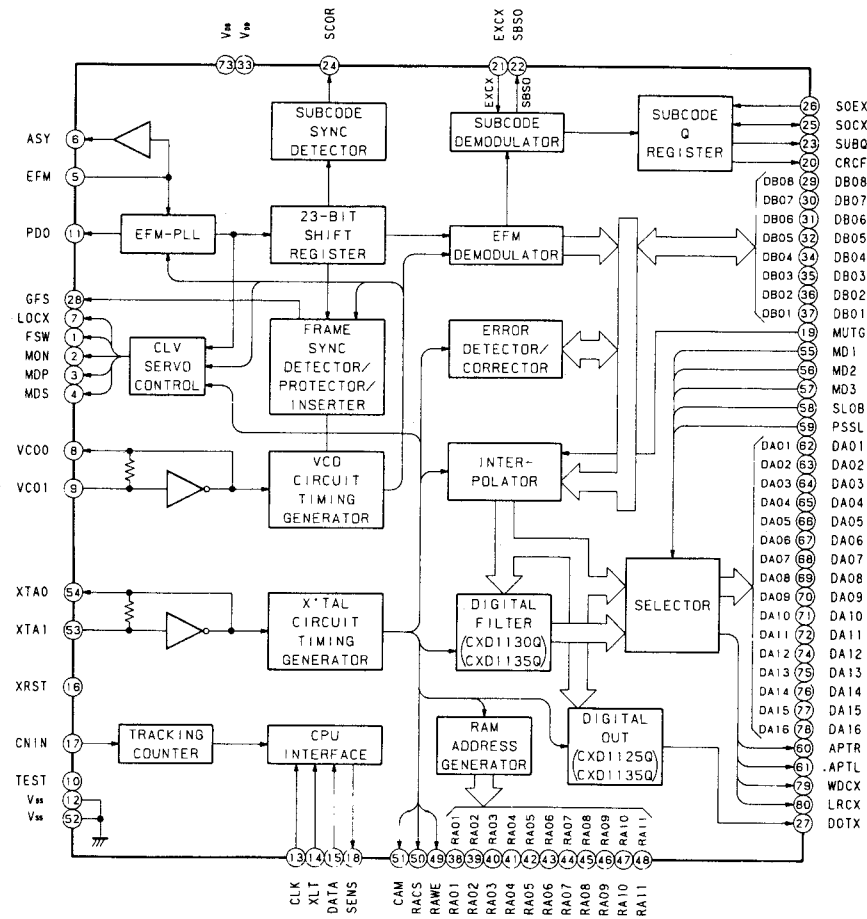
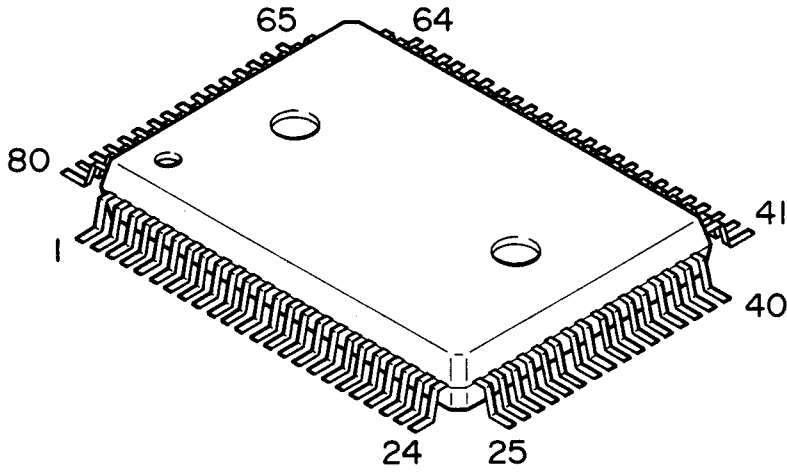

**LC3516AS: IC206**

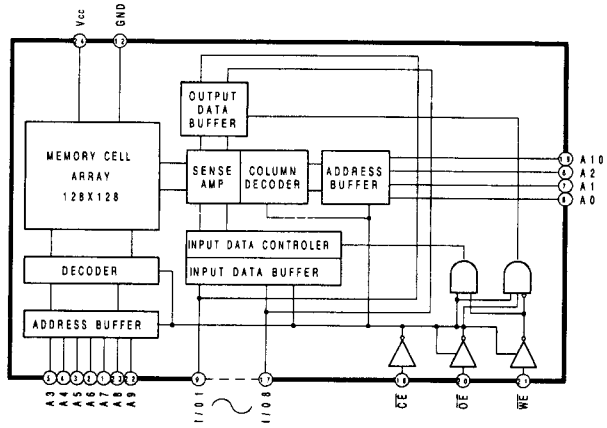
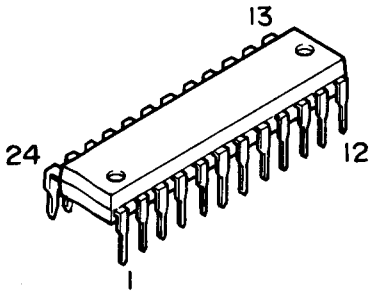

**SM5813AP: IC209**

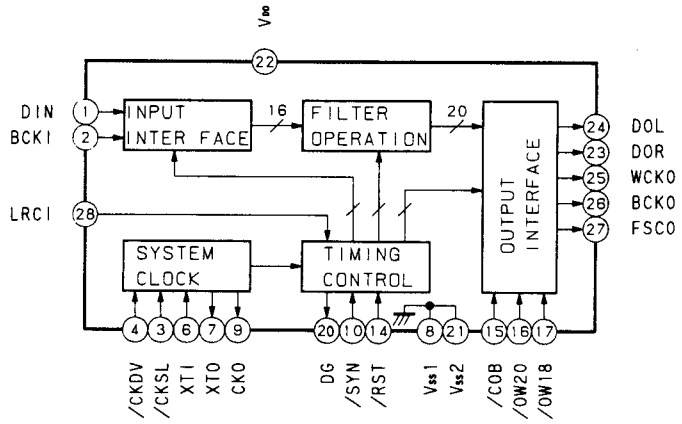
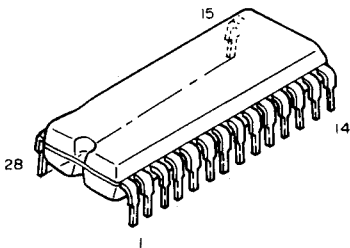

**NJM2903S: IC210**

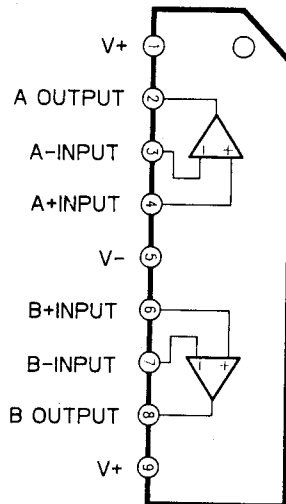
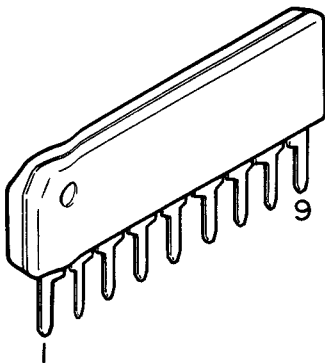

**AD1860: IC211 or IC212**

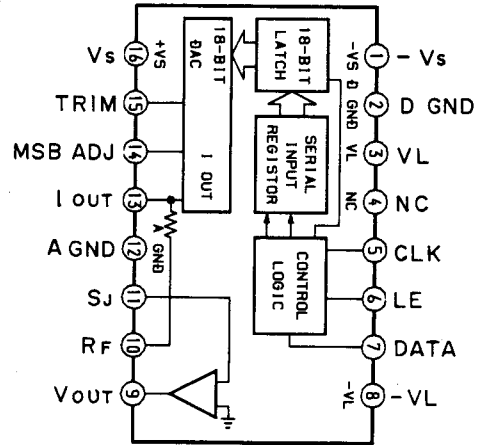
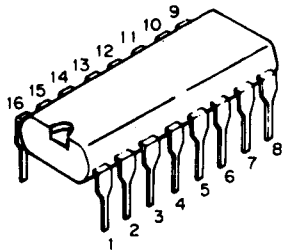

**LA6501LR: IC213, IC218**

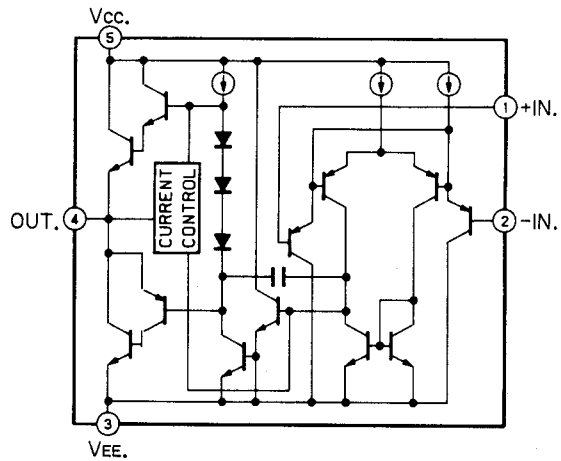
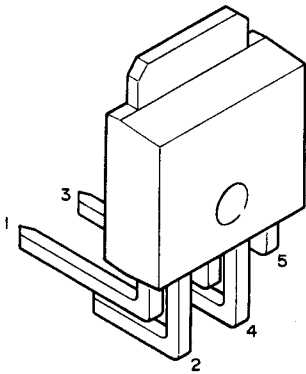

**NJM7905FA: IC214 or 217**

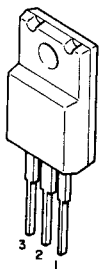

1: OUTPUT  
2: INPUT  
3: COMMON

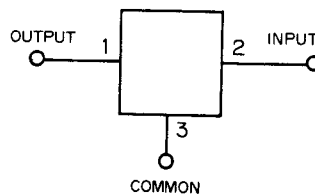



**NJM7805FA: IC216**

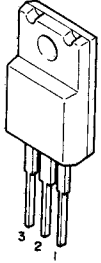

1: OUTPUT  
2: COMMON  
3: INPUT

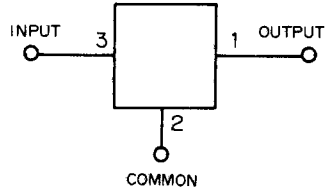

**GP1U521: IC501  
or GP1U521X**

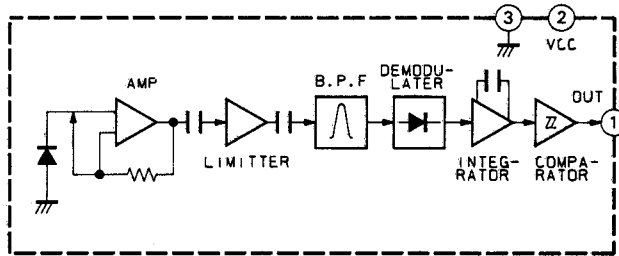
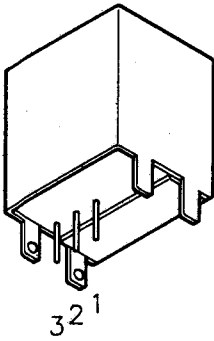



V11325

# SERVICE MANUAL

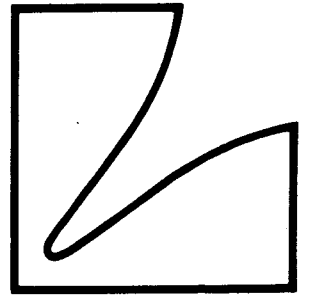

Compact Disc Player

# D-105U

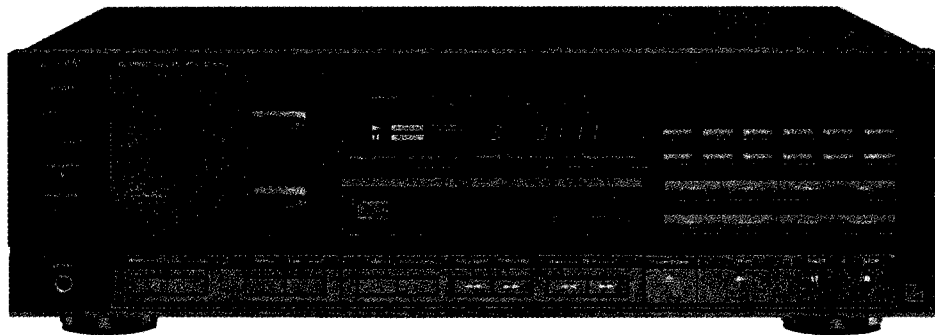

---

## Contents

---

Specifications .....	3
Parts Locations and Disassembly Instructions .....	4 to 13
Adjustment Procedures .....	14 to 15
Adjustment Location .....	16 to 17
Block Diagram .....	18
Schematic Diagram .....	19 to 32
Parts Layout on P.C. Boards and Wiring Diagram .....	33 to 40
Electrical Parts List .....	41 to 46
Exploded View (Cabinet) .....	47 to 48
Cabinet Assembly Parts List .....	49 to 50
Packing Assembly Parts List .....	51
Packing Method View .....	51
Semi-Conductor Lead Identifications .....	52 to 63

Note : ● : For Japanese model only (JA)  
▲ : For General Foreign model only (EK)  
Others : Common

◆ : For American model only (UZ)  
■ : For West German model only (AD)  
◇ : For Canadian model only (UQ)  
□ : For England model only (AG)

---

**Specifications**

---

**CD SECTION**

Systems .....	Optical (Compact Disc System)
Quantizing Bit Number .....	16 Bit Linear System
Channels .....	2 Channels, Stereo
Pick-up .....	Semiconductor Laser Pick-up
Output Voltage .....	2.1V±1dB
Frequency Response .....	5~20kHz±1.6dB
T.H.D (1KHz) .....	0.12%
S/N Ratio .....	96dB
Dynamic Range .....	87dB
Separation (1KHz) .....	82dB
Head-phone Output Voltage (1kHz, 10dB/8ohm) .....	130mV±1dB
Power Supply .....	AC100V, 50/60Hz (JA Model Only) AC120/220/240V, 50Hz (EK/AD/AG Model Only) AC120V, 60Hz (UZ/UQ Model Only)
Power Consumption .....	25W
Semiconductors .....	25IC's, 26 Transistors, 40 Diodes, 2 Zener Diodes, 2 Vacume Tubes (AD/UZ/AG/UQ Model Only) 25IC's, 26 Transistors, 39 Diodes, 2 Zener Diodes, 2 Vacume Tubes (JA/EK Model Only)
Dimension (W×H×D) .....	438×147×342mm
Weight .....	8.5kg

**COMPACT DISC**

Track Pitch .....	1.6μm
Modulation Frequency .....	44.1MHz
Transfer Rate .....	4.3218MBit/sec
Dimension .....	120×1.2mm

## Parts Locations and Disassembly Instructions

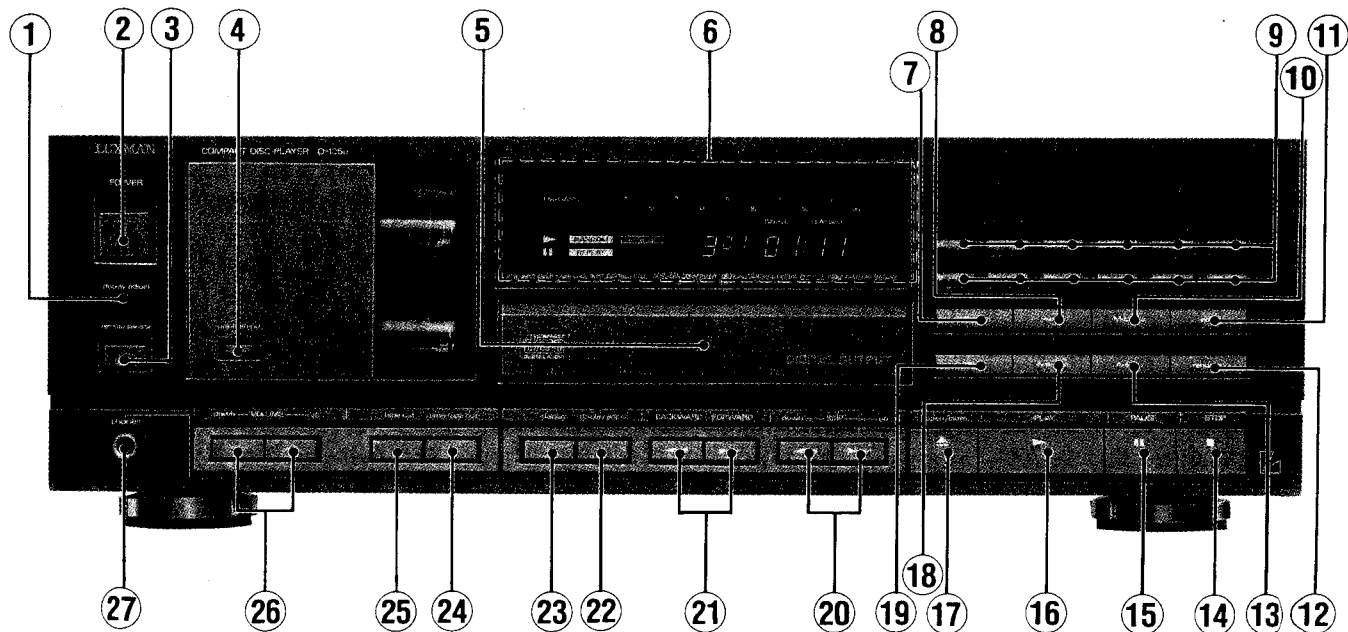

Figure 1 < 1 ☒ >

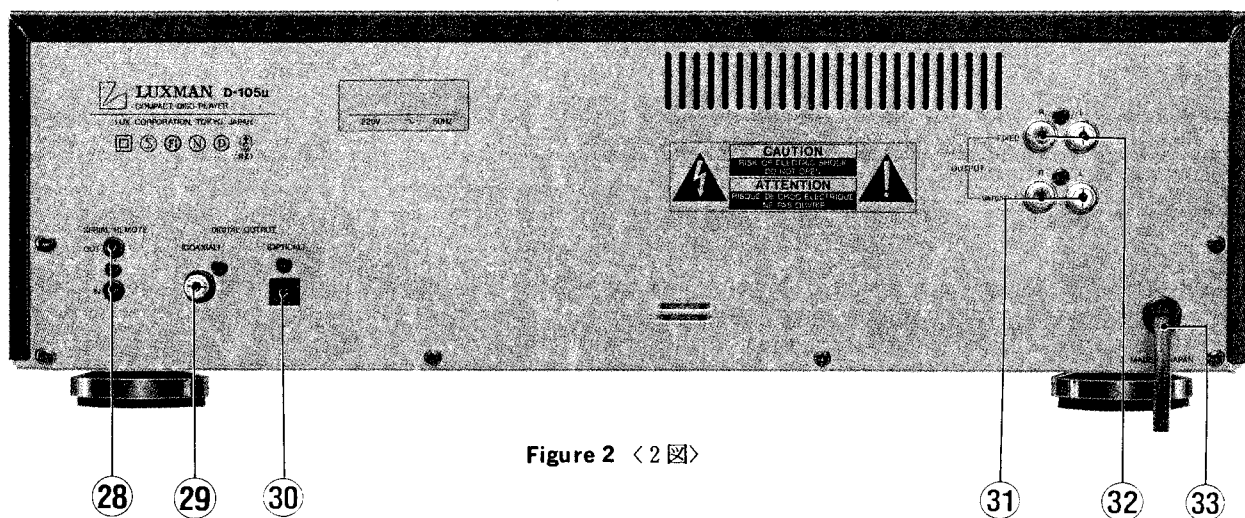

Figure 2 < 2 ☒ >

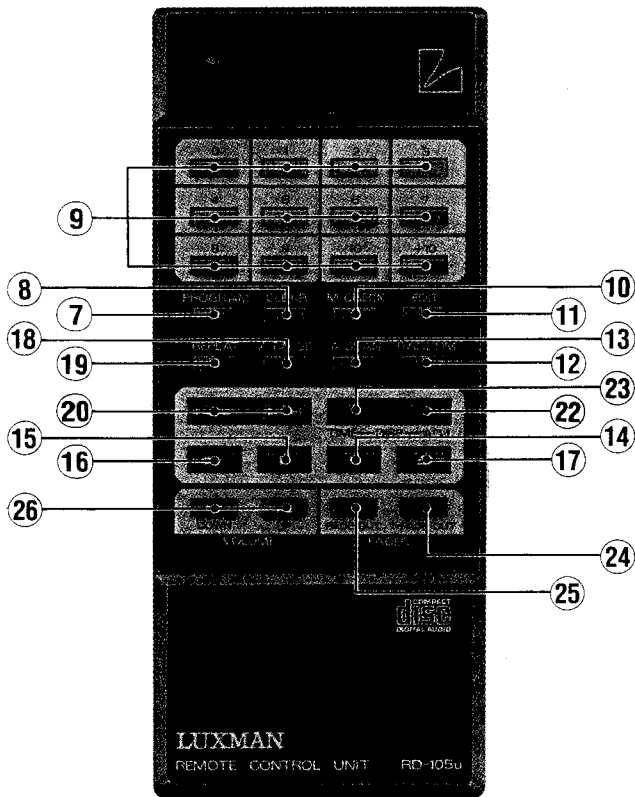

Figure 3 &lt; 3 ☒ &gt;

- ① "display adjust" indicator
- ② POWER button
- ③ "remote sensor"
- ④ "pre-heating" button
- ⑤ Disc tray
- ⑥ Display
- ⑦ "program" button
- ⑧ "clear" button
- ⑨ Number buttons (0 to 10 and +10)
- ⑩ "M-Check" (memory check button)
- ⑪ "edit" button
- ⑫ "random" button
- ⑬ "A-Scan" (auto scan) button
- ⑭ STOP button (■)
- ⑮ PAUSE button (||)
- ⑯ PLAY button (▶)
- ⑰ "open/close" button
- ⑱ "A-pause" (auto pause) button
- ⑲ "repeat" button
- ⑳ SKIPUP/SKIP DOWN buttons (▶▶|/|◀◀)
- ㉑ FORWARD/BACKWARD buttons (▶▶/◀◀)
- ㉒ DISPLAY ADJUST button
- ㉓ "T-display" button
- ㉔ TIME FADE-OUT button
- ㉕ FADE-OUT button
- ㉖ VOLUME "up/down" buttons (▲ ▼)
- ㉗ "phones" jack
- ㉘ SERIAL REMOTE IN/OUT jacks
- ㉙ DIGITAL OUTPUT (COAX.) jack
- ㉚ DIGITAL OUTPUT (OPT.) jack
- ㉛ VARIABLE OUTPUT R/L jack
- ㉜ FIXED OUTPUT R/L jack
- ㉝ Power cord

## 〈Cabinet of Section〉

### 1. Removal of Top Cover

- (1) Remove ten screws marked "●" as shown Figure 4.
- (2) Pull out the top cover in the direction of the arrow as shown in Figure 4.

#### 1. 上蓋の外し方

- (1) 10本のネジ"●"を外します。(4図参照)
- (2) 上蓋を矢印の方向に引き上げて外します。(4図参照)

### 2. Removal of the Front Panel

- (1) After removing the Top Cover, open the Disk Tray and pull the Tray Panel in the direction as shown in Figure 5.
- (2) Remove the Power switch knob as shown in Figure 5.
- (3) Remove the solder (A) as shown in Figure 6.  
Note: Be careful not to damage the parallel wires (29P) when removing the solder (A).
- (4) Remove the three screws marked "○" as shown in Figure 7.
- (5) Remove the hook (A) located in the two places as shown in Figure 6.
- (6) Disconnect all wires connected to the following P.C. Boards: FL/Keyboard P.C. Board, Tube P.C. Board (1)/(2), Remote P.C. Board, Pre-Heat SW. P.C. Board, Head-Phone Jack P.C. Board.
- (7) The Front Panel can now be removed with the following P.C. Boards in place: FL/Keyboard P.C. Board, Tube P.C. Board (1)/(2), Remote P.C. Board, Pre-Heat SW. P.C. Board, Head-Phone Jack P.C. Board, Fade P.C. Board.

#### 2. フロントパネルの外し方

- (1) 上蓋を外した後、ディスクトレイをオープンし、トレイパネルを矢印の方向に外します。(5図参照)
- (2) パワースイッチつまみを外します。(5図参照)
- (3) 半田(A)を外します。(6図参照)  
注) 半田(A)を外す際、パラレルワイヤー (29P) が損傷し易いので十分注意して下さい。
- (4) 3本のネジ (○印) を外します。(7図参照)
- (5) 2箇所のフック(A)を外します。(6図参照)
- (6) FL/Key Board 基板・Tube 基板(1)/(2)・Remote 基板・Pre-Heat SW 基板・Head-Phone Jack 基板以上の基板からつながる全てのワイヤーを外します。
- (7) 以上でフロントパネルはFL/Key Board 基板 Tube 基板(1)/(2)・Remote 基板・Pre-Heat SW 基板・Head-Phone Jack 基板・Fade 基板の各基板が付いた状態で外すことができます。

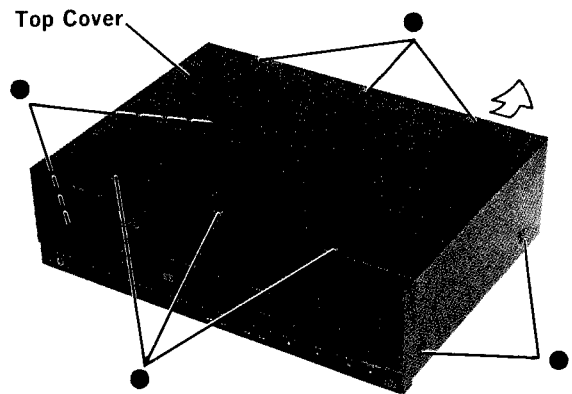

Figure 4 &lt;4図&gt;

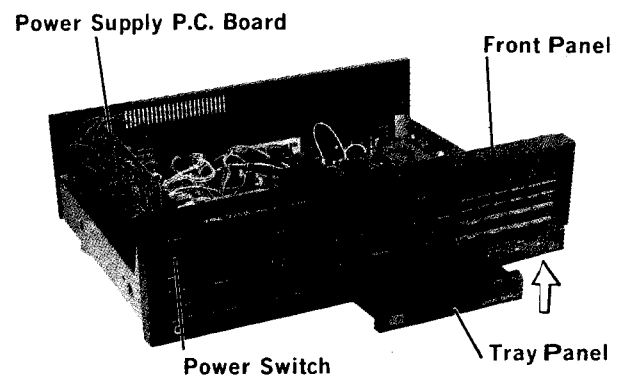

Figure 5 &lt;5図&gt;

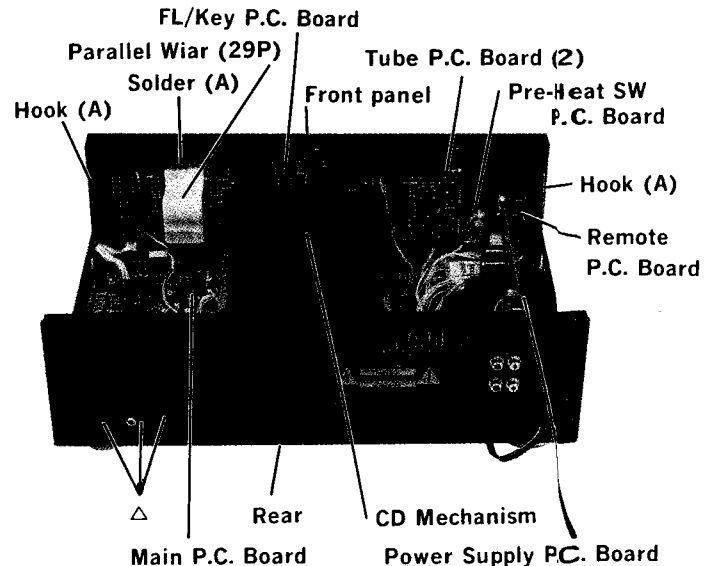

Figure 6 &lt;6図&gt;

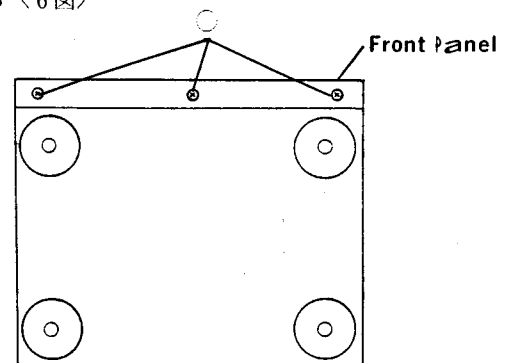

Figure 7 &lt;7図&gt;

**3. Removal of the CD mechanism**

- (1) After removing the Front Panel remove the five screws marked "X" as shown in Figure 8.
- (2) Disconnect all wires connected to the CD mechanism.
- (3) the CD mechanism can now be removed.

**3. CDメカニズムの外し方**

- (1) フロントパネルを外した後、5本のネジ(×印)を外します。(8図参照)
- (2) CDメカニズムにつながる全てのワイヤーを外します。
- (3) 以上でCDメカニズムは外れます。

**4. Removal of the Main P.C. Board**

- (1) After removing the Top Cover, remove the seven screws marked "△" as shown in Figures 6 and 8.
- (2) Hold down on "A" (see Fig. 9) and remove P.C. Board support (C) as shown in Figure 8.
- (3) Disconnect all wires connected to the Main P.C. Board.
- (4) The Main P.C. Board can now be removed.

**4. MAIN基板の外し方**

- (1) 上蓋を外した後、7本のネジ(△印)を外します。(6, 8図参照)
- (2) A部を押しながら(9図参照)基板サポート(C)を外します。(8図参照)
- (3) MAIN基板につながる全てのワイヤーを外します。
- (4) 以上でMAIN基板は外れます。

**5. Removal of the FL/Keyboard P.C. Board**

- (1) After removing the Front Panel, remove the two screws marked "☆" as in Figure 10.
- (2) Remove the hook (D) in the fifteen places as shown in Figure 10.
- (3) Disconnect the 6P connector connected to the Fade P.C. Board.
- (4) The FL/Keyboard P.C. Board can now be removed.

**5. FL/Keyboard基板の外し方**

- (1) フロントパネルを外した後2本のネジ(☆印)を外します。(10図参照)
- (2) 15箇所のフック(D)を外します。(10図参照)
- (3) Fade基板につながる1つのコネクタ(6P)を外します。
- (4) 以上でFL/Keyboard基板は外れます。

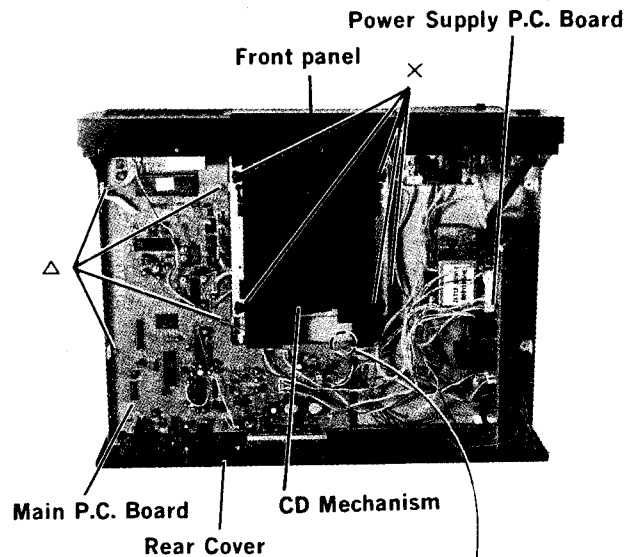

Figure 8 <8図>

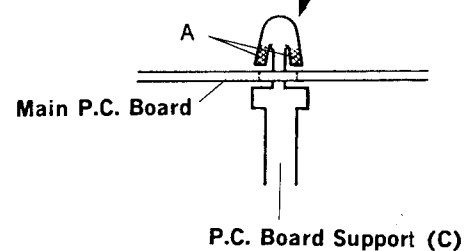

Figure 9 <9図>

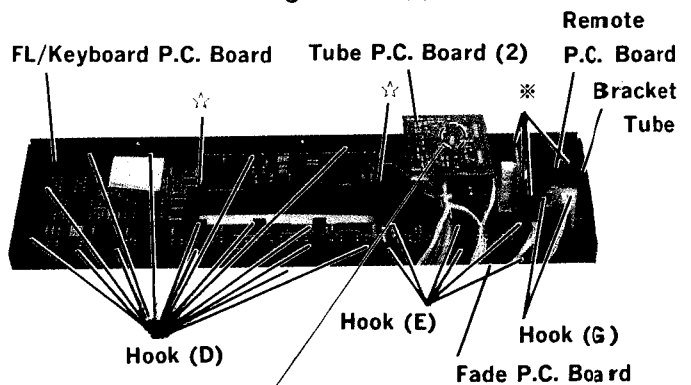

Figure 10 <10図>

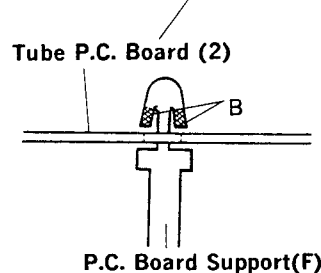

Figure 11 <11図>

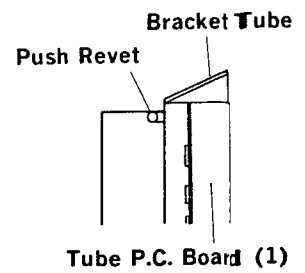

Figure 12 <12図>



**6. Removal of the Fade P.C. Board**

- (1) After removing the Front Panel, remove the hook (E) in the six places as shown in Figure 10.
- (2) Disconnect the 6P connector connected to the FL/Keyboard P.C. Board.
- (3) The Fade P.C. Board can now be removed.

**6. Fade 基板の外し方**

- (1) フロントパネルを外した後、6箇所のフック(E)を外します。(10図参照)
- (2) FL/Keyboard 基板につながる1つのコネクタ (6P) を外します。
- (3) 以上で Fade 基板は外れます。

**7. Removal of the Tube P.C. Board (2)**

- (1) After removing the Front Panel, hold down on "B" (see Fig. 11) and remove the P.C. Board support (F) as shown in Figure 10.
- (2) Disconnect the two 6P connectors connected to the Tube P.C. Board (2).
- (3) The Tube P.C. Board (2) can now be removed.

**7. Tube 基板(2)の外し方**

- (1) フロントパネルを外した後、B部分を押しながら(11図参照) 基板サポート(F)を外します。(10図参照)
- (2) Tube 基板(1)につながる2つのコネクタ (それぞれ6P) を引き抜きます。
- (3) 以上で Tube 基板(2)は外れます。

**8. Removal of the Tube P.C. Board (1)**

- (1) After removing the Front Panel and Tube P.C. Board (2), remove the four screws marked "\*" and the Tube retainer as shown in Figure 10.
- (2) Remove the Push rivet shown in Figure 12.
- (3) The Tube P.C. Board (1) can now be removed.

**8. Tube 基板(1)の外し方**

- (1) フロントパネルと Tube 基板(2)を外した後、4本のネジ(※印)を外し、チューブ取付金具を外します。(10図参照)
- (2) 1個のプッシュリベットを外します。(12図参照)
- (3) 以上で Tube 基板(1)は外れます。

**9. Removal of the Remote P.C. Board**

- (1) After removing the Tube retainer, remove the hook (G) in the two places as shown in Figure 10.
- (2) The Remote P.C. Board can now be removed.

**9. Remote 基板の外し方**

- (1) チューブ取付金具を外した後、2箇所のフック(G)を外します。(10図参照)
- (2) 以上で Remote 基板は外れます。

## <CD Mechanism Section>

### 1. Removal of Disc Tray

- (1) Pull out the disc tray in the arrow direction by pressing slant position of the disc tray as shown in Figures 13 and 14.
- (2) After disengaging one claw (A), remove the switch arm as shown in Figure 15.
- (3) Spread two claws (B) toward outside at the both sides of the disc tray and draw out the disc tray as shown in Figure 14.

#### 1. ディスクトレイの外し方

- (1) ディスクトレイの斜線部分を押し、ディスクトレイを矢印方向に引き出す。(13, 14図参照)
- (2) 爪(A)を外し、スイッチアームを外します。(15図参照)
- (3) ディスクトレイ両サイドの爪(B)を両外側に押し広げてディスクトレイを引き抜きます。(14図参照)

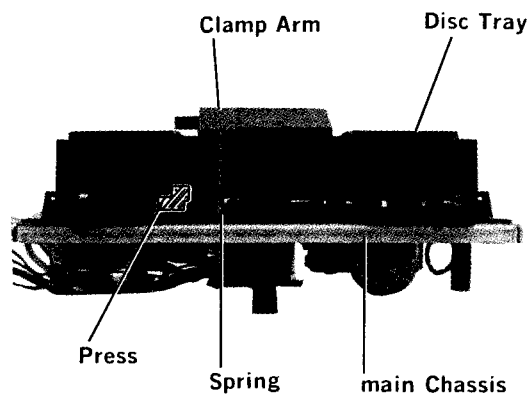

Figure 13 <13図>

### 2. Removal of Clamp Arm

- (1) Remove one spring between the main chassis and the clamp arm as shown in Figure 13.
- (2) After pulling out the disc tray forward, remove the clamp arm by pressing one claw (C) as shown in Figure 14.

#### 2. クランプアームの外し方

- (1) メインシャーシとクランプアームとを止めているバネを外します。(13図参照)
- (2) ディスクトレイを前面に引き出した後爪(C)を押しながらクランプアームを外します。(14図参照)

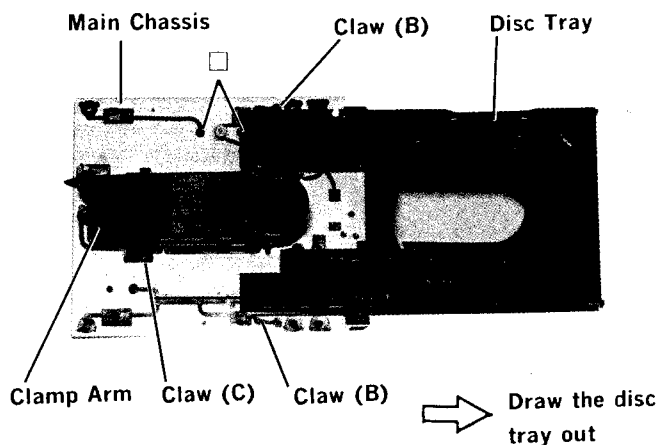

Figure 14 <14図>

### 3. Removal of Optical Pick-up Arm

- (1) After removing three screws marked "○", remove the sub-chassis as shown in Figure 15.

Note: When three screws are removed, three springs (one is black) appear under the damper bush. When assembling the sub-chassis put the black spring into the place marked "☆".

- (2) While pressing two claws (D) in toward pull out two shafts in the arrow direction as shown in Figure 17.

#### 3. 光学系ピックアップの外し方

- (1) 3本のネジ(○印)を外し、サブシャーシを外します。

注意) 3本のネジを外すとそれぞれのダンパーブッシュの下に3本のバネ(内1本が黒色)があります。サブシャーシ取り付け時には、黒色バネを"☆"色の部分に入れて取り付けして下さい。

(15図参照)

- (2) 2ヶ所の爪(D)を両方共に内側に押しながら、2本のシャフトを矢印の方向に引き抜きます。(17図参照)

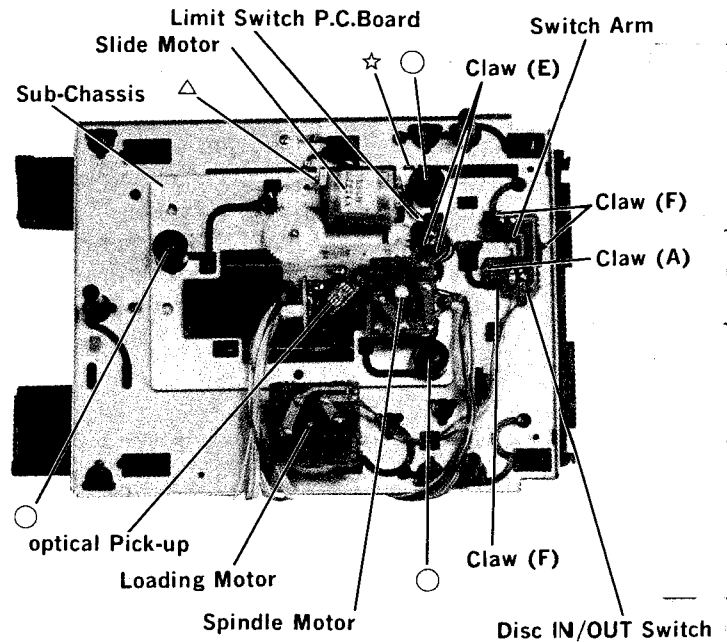

Figure 15 <15図>

### 4. Removal of Spindle Motor

- (1) By grasping plastic part, lift the disc table straight up without applying pressure to metal part.

Note: For assembling the disc table, insert the disc table with pressure so that the height from the disc table top to the sub-chassis surface becomes  $19.9 \pm 0.1\text{mm}$  as shown in Figure 18.

- (2) Remove two screws marked "×" as shown in Figure 17.

#### 4. スピンドルモーターの外し方

- (1) ディスクテーブルを金属部分に負荷をかけないで樹脂の部分をつかみまっすぐ上に引き抜きます。

注意) ディスクテーブルの組立て時、サブシャーシ上面からディスクテーブルの上面までの高さ  $19.9 \pm 0.1\text{mm}$  の位置に圧入して下さい。(18図参照)

- (2) 2本のネジ(×印)を外します。(17図参照)

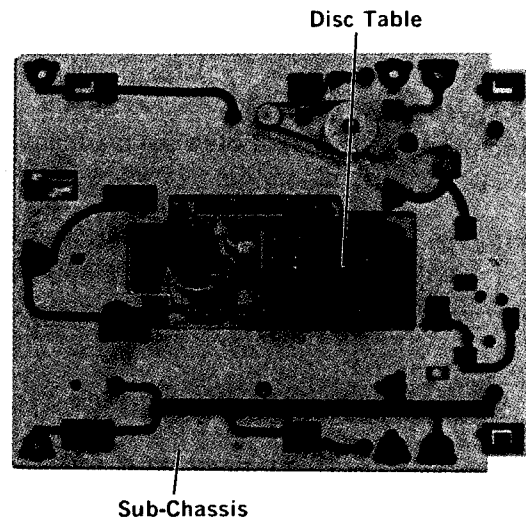

Figure 16 <16図>

### 5. Removal of Slide Motor

- (1) Remove one screw marked "△" and lift up the motor as shown in Figure 15.

### 5. スライドモーターの外し方

- (1) 1本のネジ(△印)を外し、上に持ち上げます。(15図参照)

### 6. Removal of Loading Motor

- (1) Remove one belt and two screws marked "□" as shown in Figure 14.

### 6. ローディングモーターの外し方

- (1) ベルトを外し、2本のネジ(□印)を外します。(14図参照)

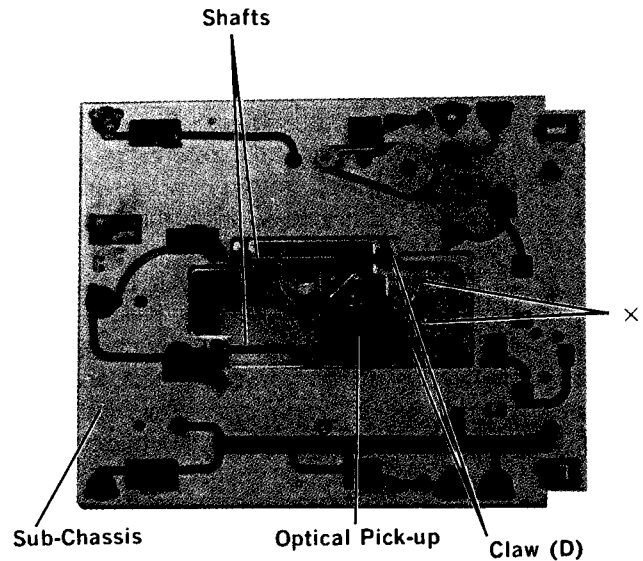

Figure 17 <17図>

### 7. Removal of Limit Switch P.C. Board

- (1) Remove two claws marked "E" as shown in Figure 15.

### 7. リミットスイッチ基板の外し方

- (1) 2ヶ所の爪(E)を外します。(15図参照)

### 8. Removal of Disc IN/OUT Switch P.C. Board

- (1) Remove three claws marked "F" as shown in Figure 15.

### 8. ディスク IN/OUT スイッチ基板の外し方

- (1) 3ヶ所の爪(F)を外します。(15図参照)

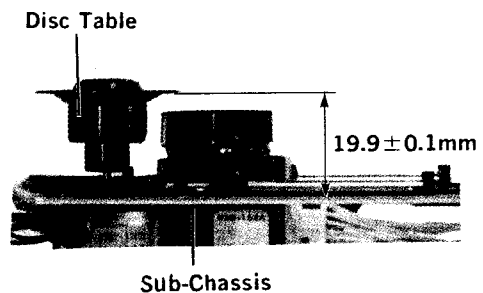

Figure 18 <18図>

## 〈Service Notes〉

### 1. Notes on Laser Diode Emission and Focus Search Operation Check

#### (1) Caution when checking Laser Diode emission.

The laser beam on this model is concentrated so as to be focused on the disc reflective surface by the objective lens in the optical pick-up block. Therefore, when checking the laser diode emission, observe from more than 30cm away from the objective lens.

#### (2) Check of the Laser Diode And Focus Search Operation

With no disc loaded and the disc tray closed, when switching the power on, check that the operation as shown in the below Figure 19 is performed, by observing the objective lens.

- ①Optical pick-up moves in outer-circle and inner-circle directions.
- ②Laser beam emits spreadingly.
- ③The objective lens perform up-and-down three times.

### 1. レーザーダイオードおよびフォーカスサーチ動作の確認

#### (1) レーザーダイオードの発光確認時の注意

本機のレーザー光は、光学系ピックアップ内の対物レンズによってディスクの反射面上に焦点を結ぶように集光されています。したがって、レーザーダイオードの発光を確認する時は、対物レンズより30cm以上目を離して下さい。

#### (2) レーザーダイオードおよびフォーカスサーチ動作のチェック方法

ディスクを入れないでディスクトレイが閉じた状態から、POWERスイッチをONさせた時、対物レンズおよび光学系ピックアップを見て、下記の様な動作が行なわれるか確認する。(19図参照)

- ①光学系ピックアップが外周方向に動き、また内周方向に動く。
- ②レーザー光の拡散した、赤い色の光が見える。
- ③対物レンズの上下運動。(3回)

Remove the Clamp Arm

(See Disassembly Instruction of Clamp Arm)

クランプアームを取り除く

(クランプアームの分解方法の項参照)

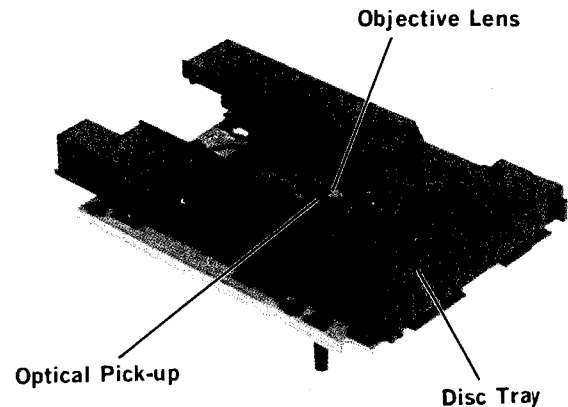

Figure 19 <19図>

## 2. Caution For Electrostatic Breakdown

### [Notes on Handling The Base Unit (KSS-152A)]

The laser diode in the optical pick-up block may suffer electrostatic breakdown because of the potential difference generated by the charged electrostatic load, etc., on clothing and the human body.

The following notes are examples for reference purposes :

- ① Perform repair with ground ring on the hands and a conductive gum mat.
- ② Grasp the slide base when handling.
- ③ When removing the pick-up arm shortcircuit by soldering as shown in the Figure 20 below and then remove the connector.
- ④ When mounting the pick-up arm, after inserting the connector, remove the soldered short-circuiting.

Notes: For making and removing the short-circuit, be sure to use an iron with its metal part grounded or its insulation resistance is higher than 10M ohms (DC 500V), and the tip temperature is lower than 320°C. The soldering and desoldering should be made quickly.

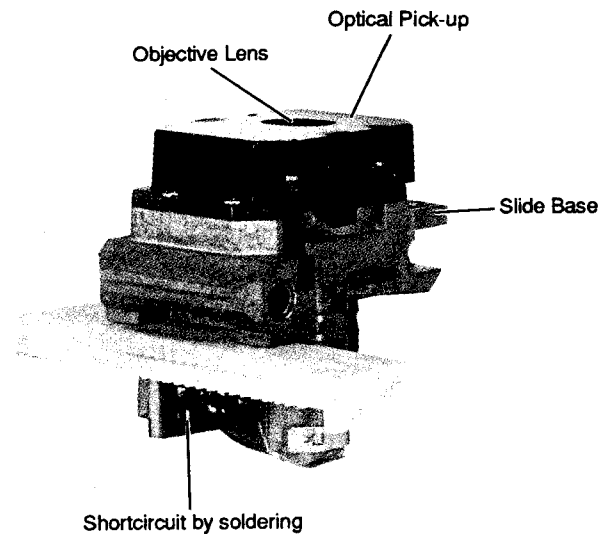

Figure 20 <20図>

## 2. 静電破壊についての注意

### [KSS-152A (光学系ピックアップ) 取扱時の注意]

光学系ピックアップ内のレーザーダイオードは、衣服や人体に帯電した静電荷等で電位差を生じることにより、静電破壊することがあります。静電破壊に対する注意として下記のこと十分に注意して取扱ってください。

- ① 取扱い時には、人体アースおよびアースマットを用いて接地してから作業を行ってください。
- ② 取扱いは、スライドベースを持って行って下さい。
- ③ 取りはずす時、20図のように半田ショートさせてから、コネクターを外して下さい。
- ④ 取付け時、コネクターを差し込んだ後、半田ショートの部分を開放して下さい。

注意) 半田ショートおよび開放時には、金属部分を接地させた半田ゴテか、もしくは通電5分後の絶縁抵抗が10MΩ以上(DC500V)のもので、コテ先温度が320°C以下の半田ゴテを使用してすみやかに行って下さい。

# Adjustment Procedures

## 1. Compact Disc Section

### (1) Connections

(1) 接続図

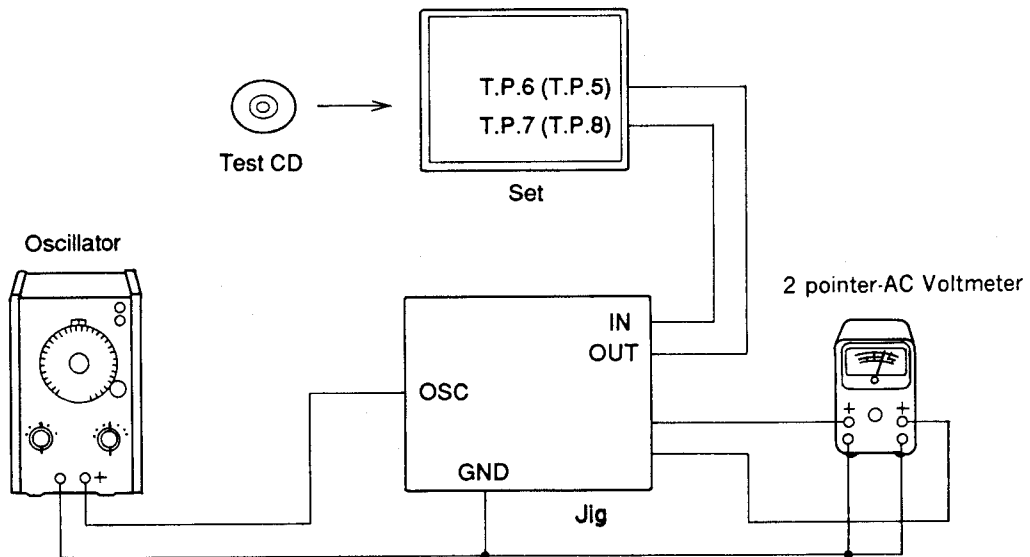
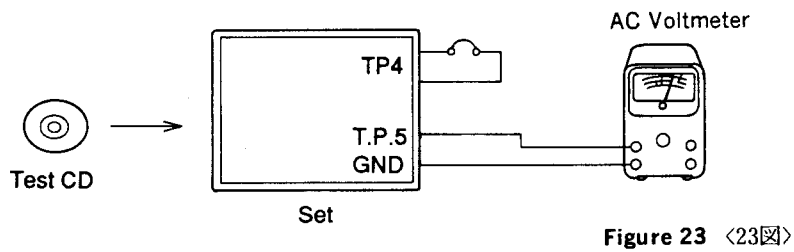
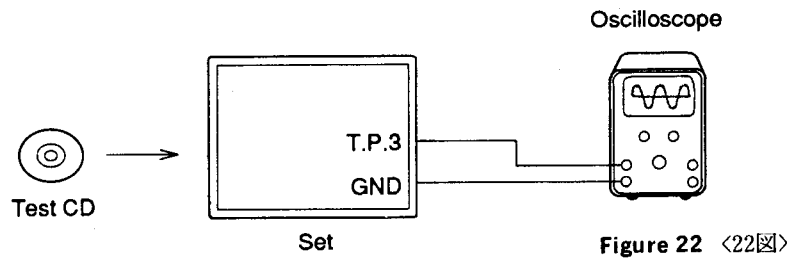
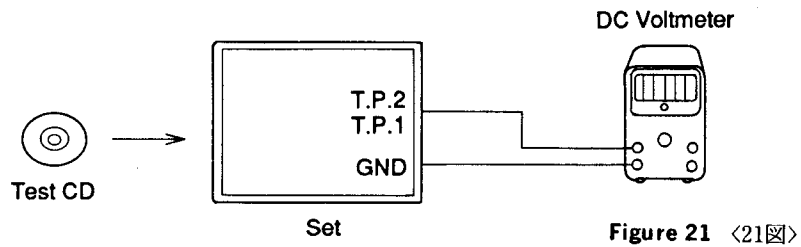

### (2) Control Settings

Power Switch .....ON  
 Play Switch .....ON  
 Others .....OFF

### (3) Test CD

Use the 2nd trak on the SONY YEDS-18 CD  
 or A-BEX TCD-782 CD.

(4) Adjustment Procedures

Step	Description	Connections	Oscillator	Test Point	Adjustment
1	VCO Adjsutment	Figure 21	—	T.P.1 T.P.2	Take measurement of the voltage at the T.P.1. Then adjsut VR202 so that the output voltage at the T.P.2 becomes 1/2 of the voltage at the T.P.1.
2	Focus Bias Adjustment	Figure 22	—	T.P.3	Adjust VR201 so that the waveform of output at the T.P.3 becomes maximum as shown on Fig. 25.
3	Tracking Error Balance Adjustment	Figure 23	—	T.P.4 T.P.5 T.P.6	After shortcircuiting between T.P.4 and T.P.5 and turning VR204 fully counter-clockwise, adjsut VR203 so that the voltage is $0V \pm 50mV$ . After the adjustment set VR204 to its center position.
4	Tracking Gain Adjustment	Figure 24	1kHz 100mV	T.P.6 T.P.7	Adjust VR204 so that both arms of the voltmeter come at the same position.
5	Focus Gain Adjustment	Figure 24	1kHz 100mV	T.P.8 T.P.9	Adjust VR205 so that both arms of the voltmeter come at the same position.

(2) スイッチ類のセット位置

- 電源スイッチ .....ON
- プレイスイッチ .....ON
- その他のスイッチ .....OFF

(3) 使用テスト CD

SONY YEDS-18 (2 曲目) 又は, A-BEX TCD-782 (2 曲目)。

(4) 調整方法

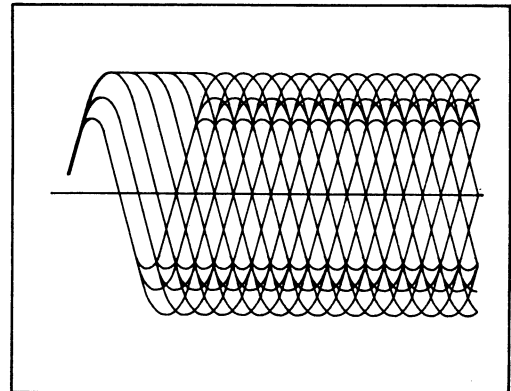

Figure 25 <25図>

順序	調整項目	接続図	オシレーター	テストポイント	調整方法
1	VCO 調整	21図	—	T.P.1 T.P.2	T.P.1の電圧を測定します。次に T.P.2の出力電圧が T.P.1の電圧の1/2になる様に VR202で調整します。
2	フォーカスバイアス調整	22図	—	T.P.3	T.P.3の出力が波形が25図の様に最大になる様に VR201で調整します。
3	トラッキングエラーバランス調整	23図	—	T.P.4 T.P.5 T.P.6	T.P.4, T.P.5の間をショートして VR204を反時計方向にしぼりきり, T.P.6の出力電圧が $0V \pm 50mV$ になる様に VR203で調整します。調整後, VR204を中央付近にもどす事。
4	トラッキングゲイン調整	24図	1kHz 100mV	T.P.6 T.P.7	2針 AC 電圧計の針が重なる様に VR204で調整します。
5	フォーカスゲイン調整	24図	1kHz 100mV	T.P.8 T.P.9	2針 AC 電圧計の針が重なる様に VR205で調整します。



# Adjustment Location

Main P.C. Board (Component Side) AD/UZ/AG/UQ model

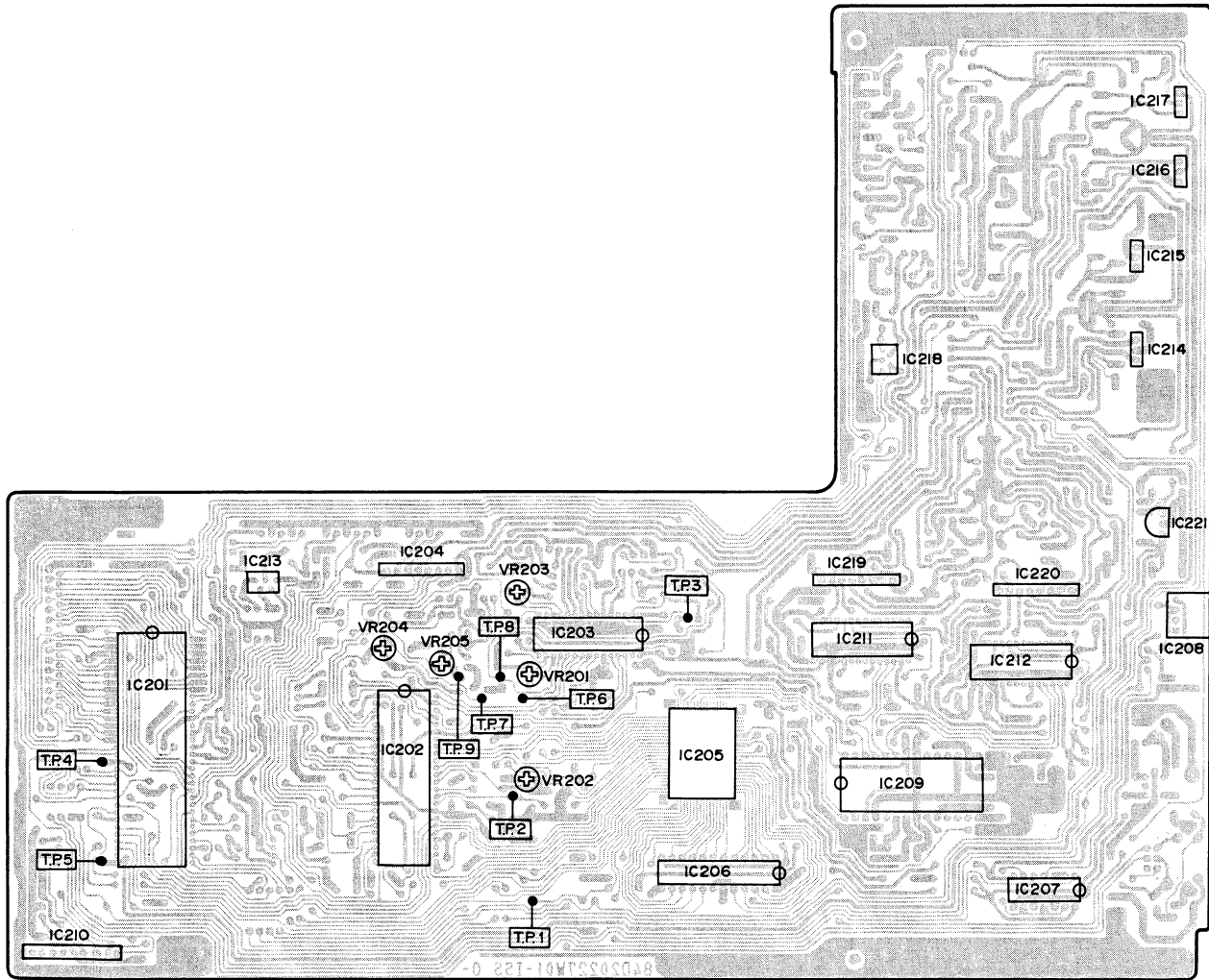

Figure 26 <26図>

Main P.C. Board (Component Side) JA/EK model

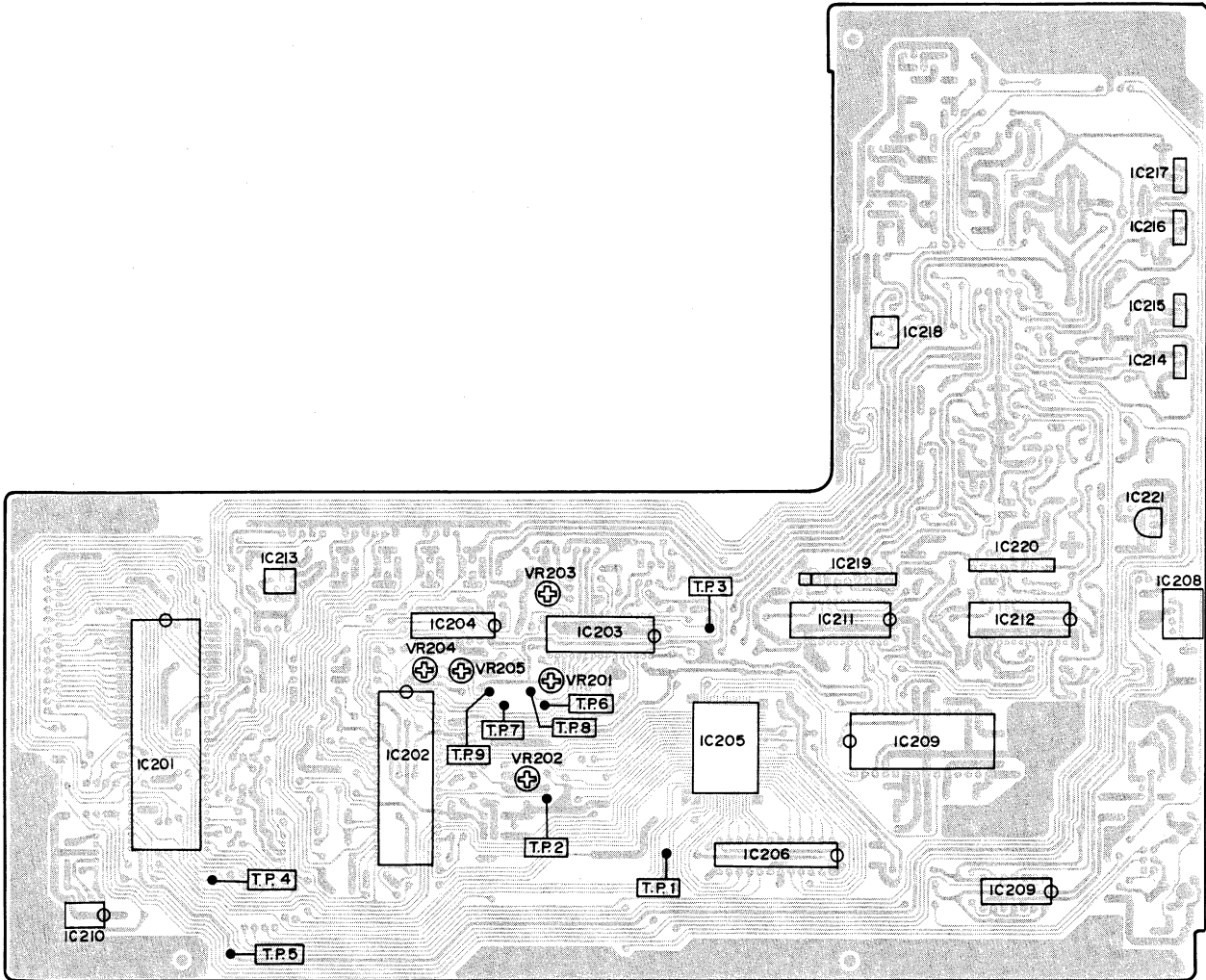
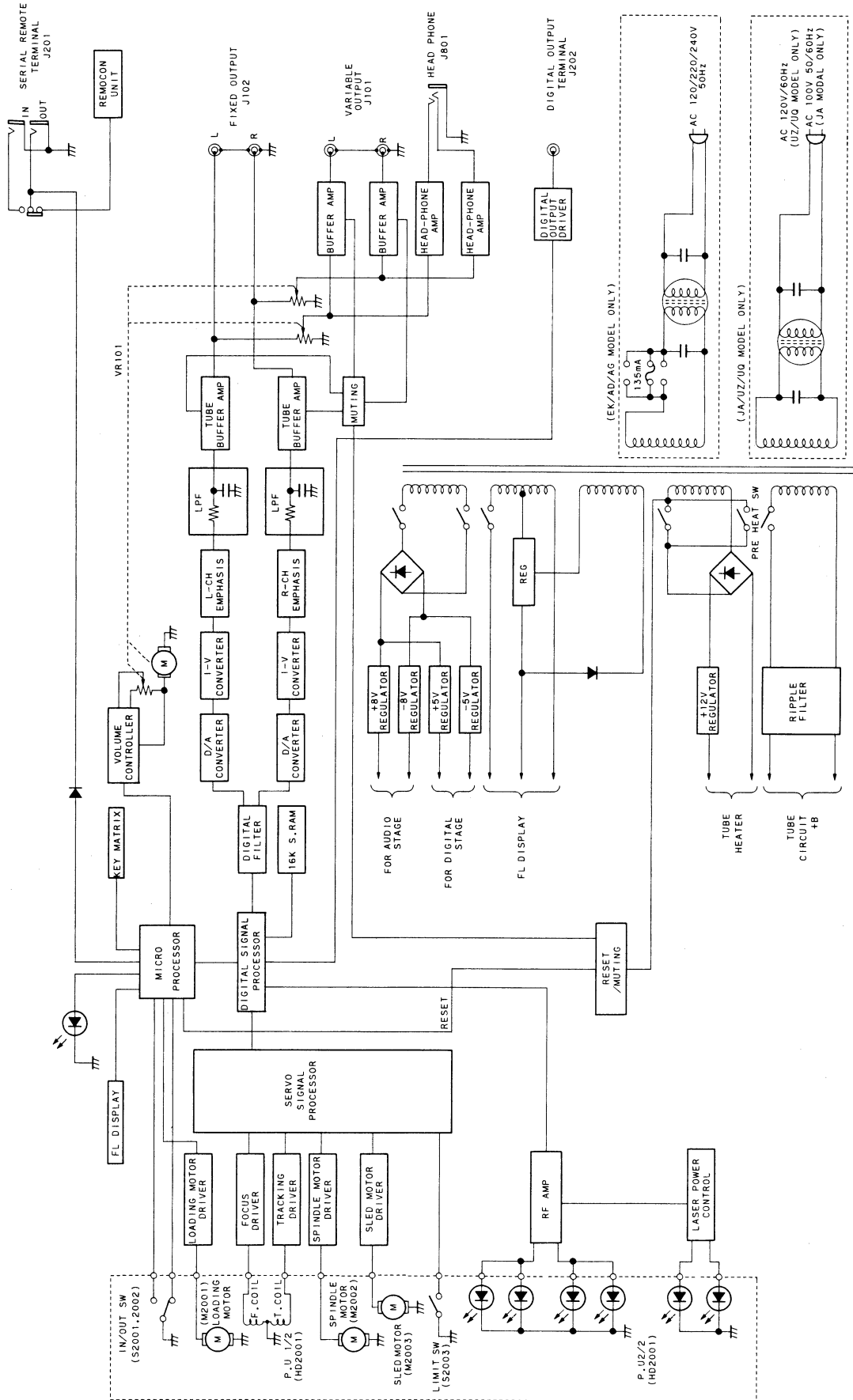

Figure 27 <27図>

# Block Diagram



# Schematic Diagram <D-105U AD/UZ/AG/UQ>(1/2)

**NOTE**  
 1. All resistance values are in ohms. K=1,000 M=1,000,000  
 2. All capacitance values are in microfarads. P=1,000,000

**Voltage Measuring Conditions**  
 1. Power Supply Voltage : AC120V./220V./240V.50Hz(AD/AG model only)  
 : AC120V./60Hz(UZ/UQ model only)  
 2. Measuring Meter : Digital Multimeter  
 3. Measuring Point Reference : Between Ground  
 4. Measuring Conditions : NO Signal Input  
 : AT Play Mode Test CD  
 (Use the 2nd trak on the YED-18)

IC'S	IC501	IC105
TRANSISTORS (Q)	Q101	Q102

IC201	IC204	IC203	IC206
1 -28.3V 33 5V	1 11.2V	1 0V	1 2.5V
2 -22.8V 34 1.4V	2 0.6V	2 1.1V	2 2.5V
3 -27.3V 35 4.8V	3 0V	3 0V	3 2.4V
4 -27.3V 36 0V	4 0V	4 0V	4 2.4V
5 -22.8V 37 4.8V	5 -12V	5 2.8V	5 2.4V
6 -32.8V 38 0V	6 0.6V	6 -4.8V	6 2.4V
7 -32.8V 39 0V	7 0V	7 0V	7 2.4V
8 -32.8V 40 0V	8 0V	8 0V	8 2.4V
9 -32.8V 41 0V	9 0V	9 0V	9 1.9V
10 -32.8V 42 0V	10 0V	10 0V	10 1.9V
11 -32.8V 43 2.2V	11 0V	11 0V	11 1.9V
12 -32.8V 44 -1.9V	12 2.4V	12 -0.6V	12 0V
13 -32.8V 45 -19.1V	13 2.4V	13 -0.4V	13 1.9V
14 -32.8V 46 -18.7V	14 2.4V	14 0V	14 1.9V
15 -32.8V 47 0V	15 2.4V	15 -2.2V	15 1.9V
16 0V 48 2.3V	16 2.4V	16 -1.9V	16 1.9V
17 -7.6V 49 2.3V	17 2.4V	17 -4.9V	17 2V
18 4.8V 50 0V	18 0V	18 0V	18 2.6V
19 -35.8V 51 0V	19 2.3V	19 0V	19 2V
20 -7.4V 52 0V	2 2.4V	20 0V	20 2.6V
21 0V 53 5V	3 2.4V	21 -4.8V	21 4.3V
22 5V 54 0V	4 2.4V	22 0V	22 2V
23 0.4V 55 0V	5 2.3V	23 -1.7V	23 2.8V
24 5V 56 0V	6 2.4V	24 -1.2V	24 4.9V
25 5V 57 -22.2V	7 0V	25 0V	* 3 : 1.2~3.5V
26 1.4V 58 -24.2V	8 2.4V	26 2.4V	
27 1.4V 59 -23.8V	9 2.4V	27 2.4V	1 4.2V
28 4.9V 60 -17.1V	10 2.4V	28 4.9V	2 2.6V
29 0V 61 -10.1V	11 2.4V	29 0.2V	
30 4.8V 62 -15.6V	12 2.4V	30 4.9V	4
31 63 -22.5V	13 2.4V		
32 5V 64 -28.8V	14 4.9V		

IC205	IC105	IC214	IC215	IC218	IC217	IC221
1 0V 41 2.4V	1 15.7V 5.7V -4.9V 7.8V -7.8V 5V	1 15.7V 5.7V -4.9V 7.8V -7.8V 5V	2 0V 0V -12.8V 0V -12.8V 0V	3 11.9V 12V 0V 12V 0V 7.9V		
2 -4.8V 42 2.4V	2 0V 0V 0V 0V 0V 0V	3 0V 0V 0V 0V 0V 0V	4 -7.8V -7.8V -7.8V -7.8V 0V			
3 2.6V 43 2.4V	5 0V 0V 0V 0V 0V 0V	6 0V 0V 0V 0V 0V 0V	7 0V 0V 0V 0V 0V 0V			
4 2.7V 44 2.8V	8 7.9V 7.9V 7.9V 7.9V 12V					
5 2.4V 45 2.5V						
6 2.4V 46 2.8V						
7 4.9V 47 2V						
8 2.4V 48 *2						
9 2.4V 49 4.3V						
10 0V 50 2.6V						
11 1.5V 51						
12 0V 52 0V						
13 4.9V 53 2.3V						
14 5V 54						
15 1.4V 55 0V						
16 5V 56 0V						
17 0V 57 4.9V						
18 4.8V 58 0V						
19 0V 59 0V						
20 60						
21 61						
22 62						
23 1.4V 63						
24 0V 64						
25 5V 65						
26 4.9V 66						
27 2.3V 67						
28 4.9V 68						
29 0V 69						
30 1.9V 70						
31 1.9V 71						
32 1.9V 72						
33 4.9V 73 4.9V						
34 1.9V 74						
35 1.9V 75						
36 1.9V 76 2.3V						
37 1.9V 77						
38 2.4V 78 2.5V						
39 2.4V 79 2.4V						
40 2.4V 80 2.5V						
* 2 : 1.2~3.5V						

**CAUTION:**  
 The symbol numbers in the schematic diagram designate components which have special characteristics important for safety and should be replaced only with types identical to those in the original circuit or specified in the parts list.

IC202	IC209	IC211	IC212
1 -4.9V 25 -4.9V	1 2.5V		
2 -4.9V 26 0V	2 2.3V		
3 0V 27	3 4.9V		
4 0V 28 5V	4 4.9V		
5 0V 29 0V			
6 0V 30 5V			
7 0V 31 5V			
8 0V 32 0V			
9 0V 33 2.4V			
10 0V 34 2.5V			
11 1V 35 2.9V			
12 0V 36 2.3V			
13 0.3V 37 3.5V			
14 0V 38 2.5V			
15 0V 39 4.9V			
16 4.9V 40 2.5V			
17 0V 41 4.8V			
18 -3.2V 42 2.5V			
19 0V 43 4.9V			
20 0V 44 0V			
21 0V 45 1.1V			
22 -4.9V 46 2.4V			
23 -4V 47 0V			
24 4.8V 48 0V			
* 1 : -0.7~0.9V			

Q101	E	C	B
Q101	-30.2V	-43.8V	-30.7V
Q102	85.1V	130.5V	85.6V
Q103	0V	0V	-7.6V
Q104	0V	0V	-7.6V
Q105	0V	0V	-7.6V
Q106	0V	0V	-7.6V
Q107	0V	0V	-7.6V
Q108	0V	0V	-7.6V
Q201	2V	0V	2.4V
Q204	0V	0V	2.8V
Q205	11.7V	-7.5V	0V
Q206	4.9V	4.9V	0V
Q207	0V	0V	8.3V
Q208	0V	0V	8.3V
Q209	0V	0V	0V
Q210	0V	0V	0V
Q211	0V	0V	0V
Q212	0.8V	11.2V	1V
Q213	0.8V	-12V	1V
Q223	4.5V	0V	4.8V
Q224	0V	4.5V	0V
Q225	0V	0V	4.5V
Q226	0V	0V	0V

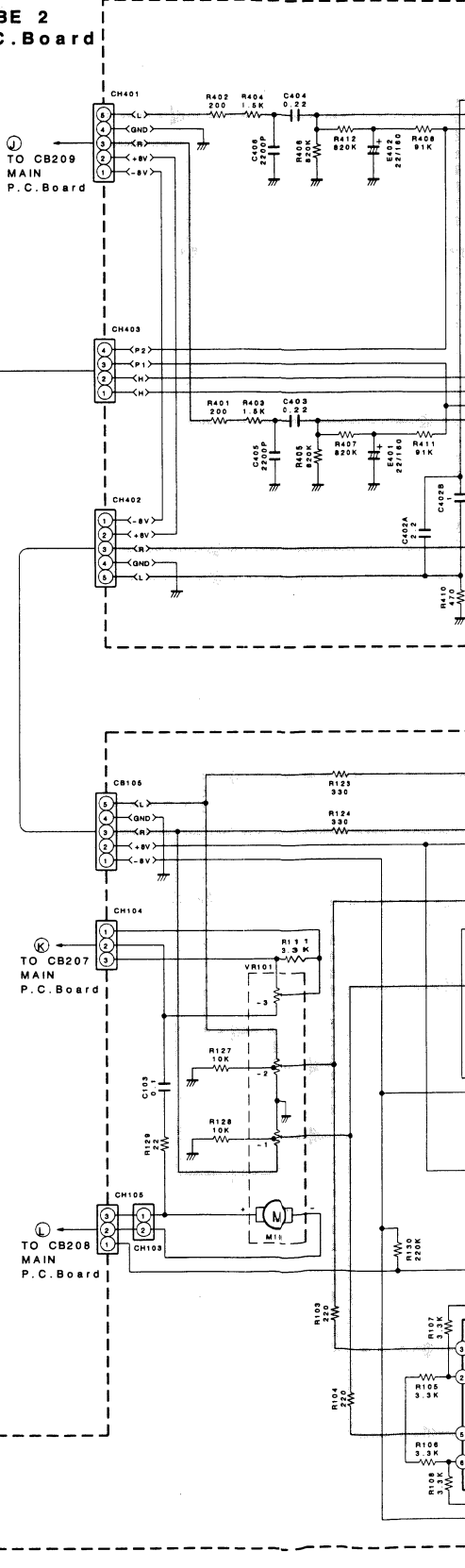
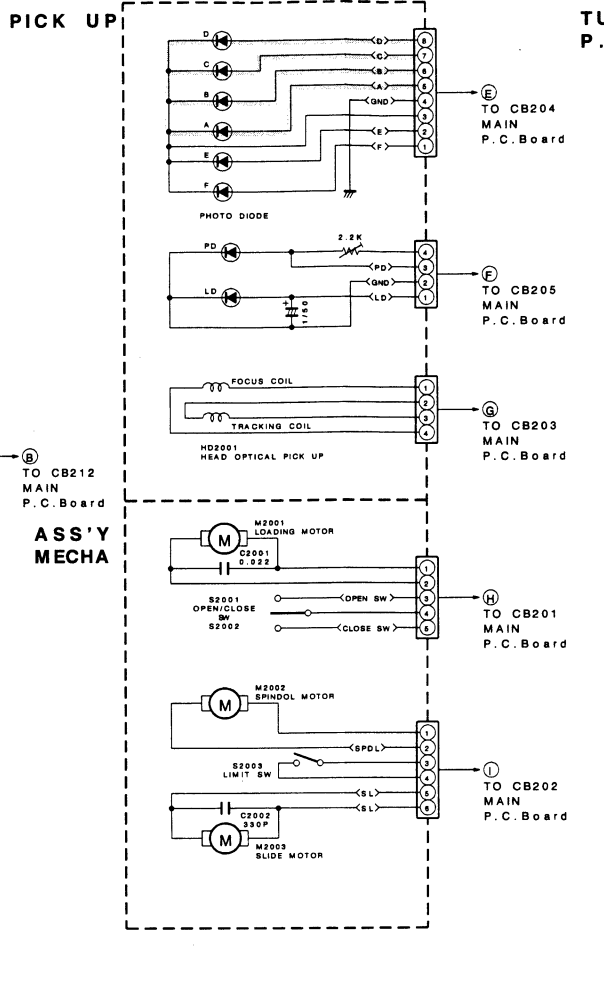
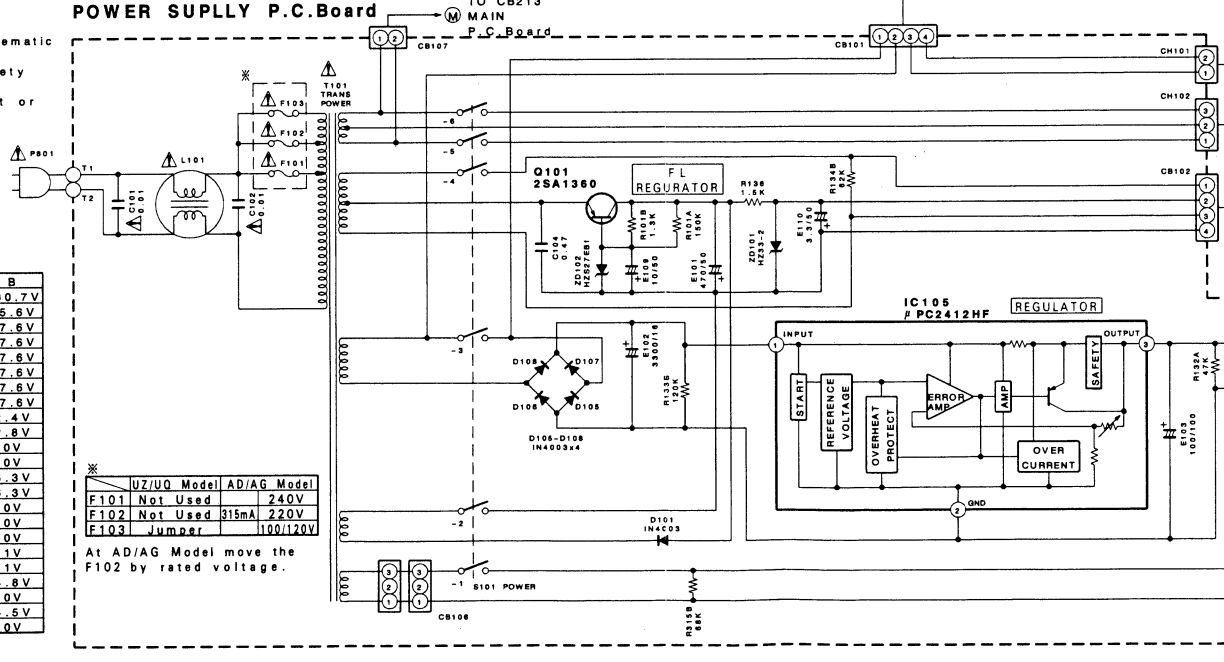
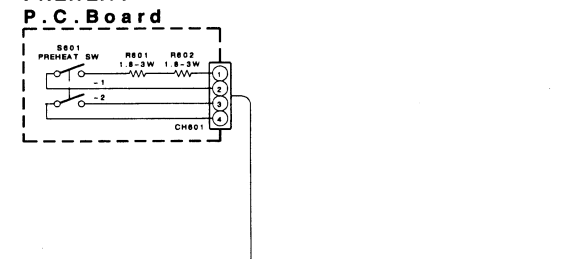
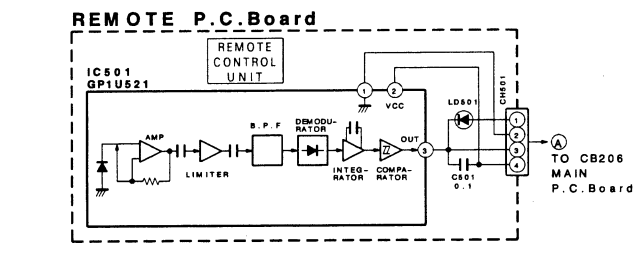
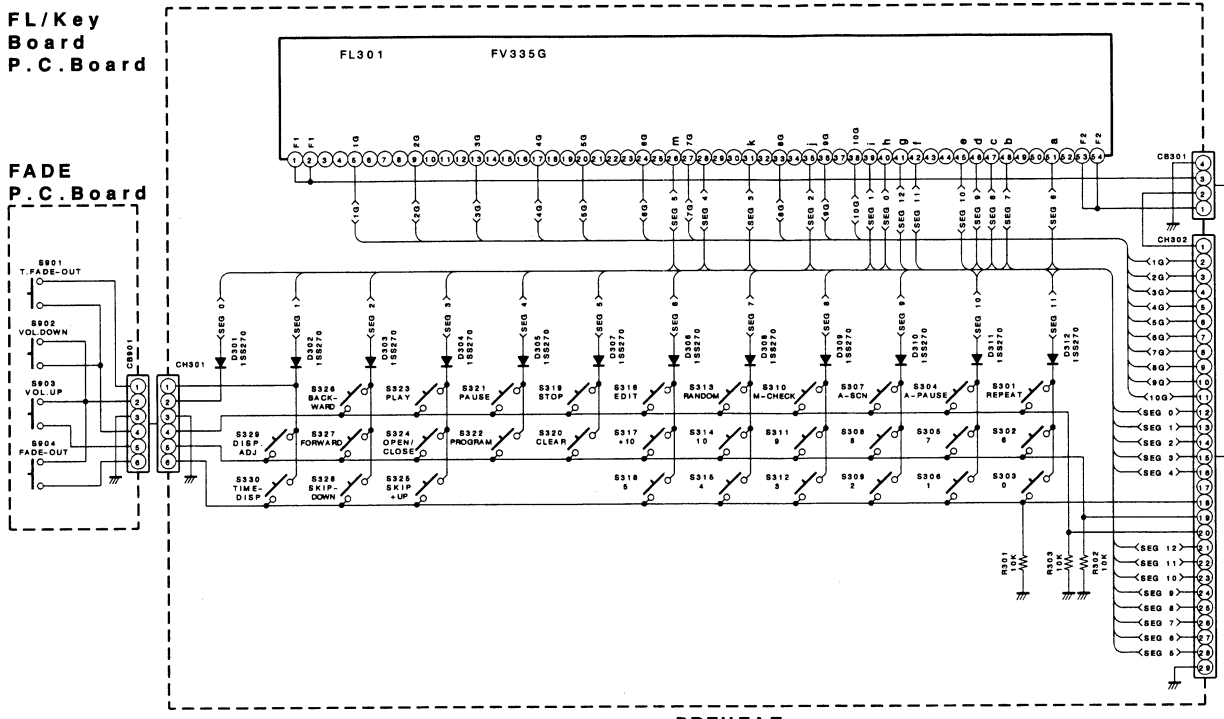

A | B | C | D | E | F | G | H | I

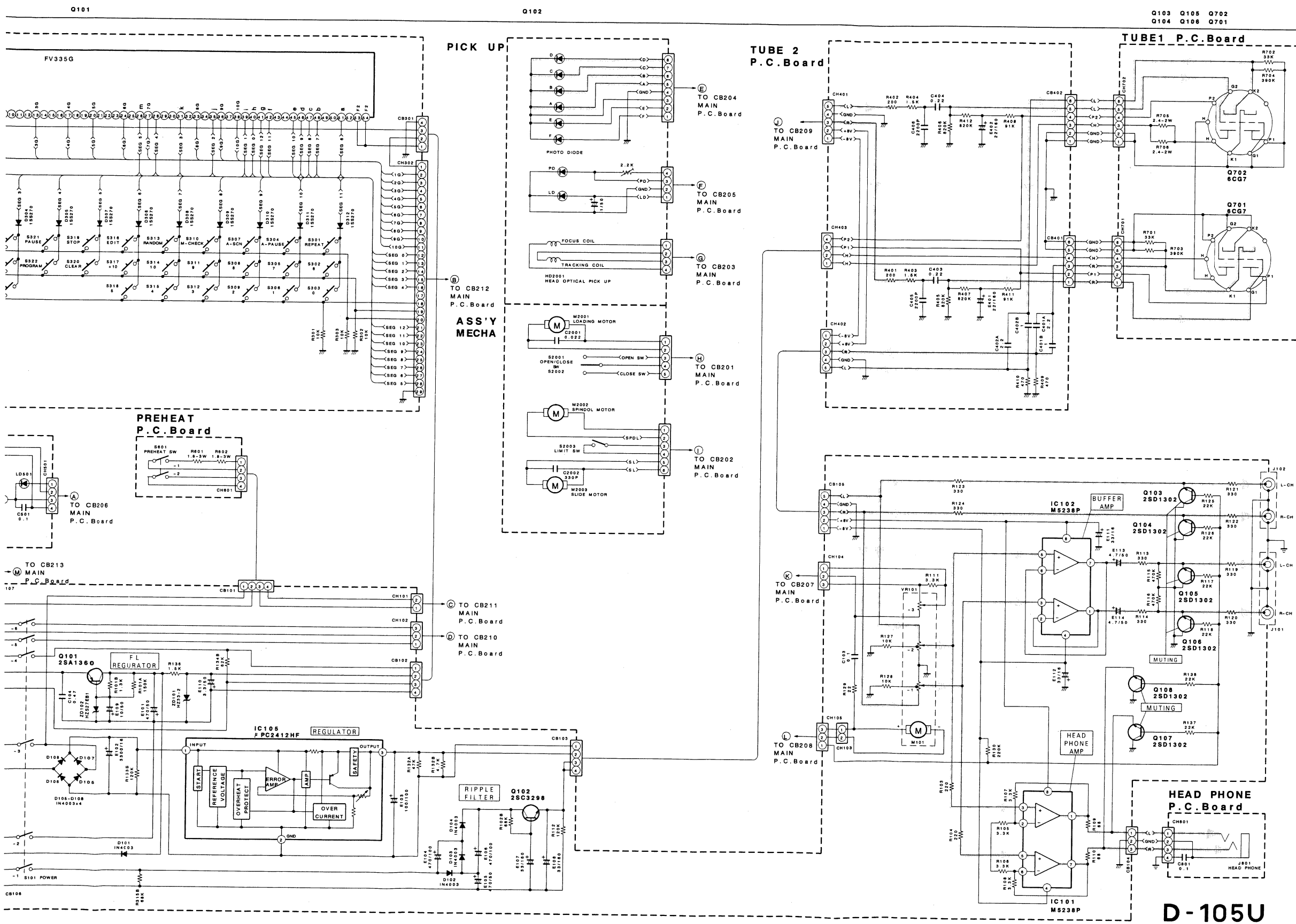

D-105U

# Schematic Diagram <D-105U JA/EK>(1/2)

**NOTE**  
 1. All resistance values are in ohms. K=1,000 M=1,000,000  
 2. All capacitance values are in microfarads. P = 1/100,000

**Voltage Measuring Conditions**  
 1. Power Supply Voltage : AC100V, 50/60Hz (JA model only)  
 : AC120V/220V/240V, 50Hz (EK model only)  
 2. Measuring Meter : Digital Multimeter  
 3. Measuring Point Reference : Between Ground  
 4. Measuring Conditions : NO Signal Input  
 : AT Play Mode Test CD  
 (Use the 2nd track on the YED-18)

IC'S	IC501	IC105	IC102
TRANSISTORS (Q)	Q101	Q102	IC101

IC201	IC204	IC203	IC206
1 -29.3V 33 5V	1 -	1 1.0V	1 2.5V
2 -22.6V 34 1.4V	2 -	2 1.1V	2 2.5V
3 -27V 35 4.9V	3 -4.9V	3 0V	3 2.4V
4 -27V 36 0V	4 -4.9V	4 2.5V	4 2.4V
5 -32.8V 37 4.9V	5 -4.9V	5 2.8V	5 2.4V
6 -32.8V 38 -	6 -4.9V	6 -4.8V	6 2.4V
7 -32.8V 39 0V	7 -4.9V	7 0V	7 2.4V
8 -32.8V 40 0V	8 -4.9V	8 0V	8 2.4V
9 -32.8V 41 0V	9 -4.8V	9 0V	9 1.9V
10 -32.8V 42 0V	10 -4.8V	10 0V	10 1.9V
11 -32.8V 43 2.2V	11 -4.8V	11 0V	11 1.9V
12 -32.8V 44 -19V	12 0V	12 -0.6V	12 0V
13 -32.8V 45 -19.1V	13 0V	13 -0.4V	13 1.9V
14 -32.8V 46 -18.7V	14 0V	14 1.9V	14 1.9V
15 -32.8V 47 0V	15 0V	15 -2.2V	15 1.9V
16 0V 48 2.3V	16 4.9V	16 -1.9V	16 1.9V
17 -7.6V 49 2.3V	17 -4.9V	17 2V	17 2V
18 4.8V 50 0V	18 0V	18 2.6V	18 2.6V
19 -35.8V 51 0V	19 0V	19 *3	19 *3
20 -7.4V 52 -	2 2.4V	20 0V	20 2.6V
21 0V 53 5V	3 2.4V	21 -4.8V	21 4.3V
22 5V 54 0V	4 2.4V	22 0V	22 2V
23 0.4V 55 0V	5 2.3V	23 -1.7V	23 2.8V
24 5V 56 0V	6 2.4V	24 -1.2V	24 4.9V
25 5V 57 -22.2V	7 0V	25 0V	*3 : 1.2~3.5V
26 1.4V 58 -24.2V	8 2.4V	26 2.4V	
27 1.4V 59 -23.8V	9 2.4V	27 2.4V	
28 4.9V 60 -17.1V	10 2.4V	28 4.9V	
29 0V 61 -10.1V	11 2.4V	29 0.2V	
30 4.8V 62 -15.6V	12 2.4V	30 4.9V	
31 -	13 2.4V		
32 5V 64 -29.8V	14 4.9V		

IC205	IC105	IC214	IC215	IC216	IC217	IC221
1 0V 41 2.4V	1 15.7V	5.7V	-4.9V	7.9V	-7.8V	5V
2 -4.8V 42 2.4V	2 0V	0V	-12.8V	0V	-12.8V	0V
3 2.5V 43 2.4V	3 11.9V	12V	0V	12V	0V	7.9V
4 2.7V 44 2.5V						
5 2.4V 45 2.5V						
6 2.4V 46 2.8V						
7 4.9V 47 2V						
8 2.4V 48 *2						
9 2.4V 49 4.3V						
10 0V 50 2.6V						
11 1.5V 51 -						
12 0V 52 0V						
13 4.9V 53 2.3V						
14 5V 54 -						
15 1.4V 55 0V						
16 5V 56 0V						
17 0V 57 4.9V						
18 4.8V 58 0V						
19 0V 59 0V						
20 -						
21 -						
22 -						
23 1.4V 62 -						
24 0V 64 -						
25 5V 65 -						
26 4.9V 66 -						
27 2.3V 67 -						
28 4.9V 68 -						
29 2V 69 -						
30 1.9V 70 -						
31 1.9V 71 -						
32 1.9V 72 -						
33 4.9V 73 4.9V						
34 1.9V 74 -						
35 1.9V 75 -						
36 1.9V 76 2.3V						
37 1.9V 77 -						
38 2.4V 78 2.5V						
39 2.4V 79 2.4V						
40 2.4V 80 2.5V						

IC101	IC102	IC219	IC220	IC210
1 0V 0V 0V 0V 0V	1 0V 0V 0V 0V 0V	1 0V 0V 0V 0V 0V	1 0V 0V 0V 0V 0V	1 0V 0V 0V 0V 0V
2 0V 0V 0V 0V 0V	2 0V 0V 0V 0V 0V	2 0V 0V 0V 0V 0V	2 0V 0V 0V 0V 0V	2 0V 0V 0V 0V 0V
3 0V 0V 0V 0V -8V	3 0V 0V 0V 0V -8V	3 0V 0V 0V 0V -8V	3 0V 0V 0V 0V -8V	3 0V 0V 0V 0V -8V
4 -7.8V -7.8V -7.8V -7.8V 0V	4 -7.8V -7.8V -7.8V -7.8V 0V	4 -7.8V -7.8V -7.8V -7.8V 0V	4 -7.8V -7.8V -7.8V -7.8V 0V	4 -7.8V -7.8V -7.8V -7.8V 0V
5 0V 0V 0V 0V -	5 0V 0V 0V 0V -	5 0V 0V 0V 0V -	5 0V 0V 0V 0V -	5 0V 0V 0V 0V -
6 0V 0V 0V 0V -	6 0V 0V 0V 0V -	6 0V 0V 0V 0V -	6 0V 0V 0V 0V -	6 0V 0V 0V 0V -
7 0V 0V 0V 0V -	7 0V 0V 0V 0V -	7 0V 0V 0V 0V -	7 0V 0V 0V 0V -	7 0V 0V 0V 0V -
8 7.9V 7.9V 7.9V 7.9V 12V	8 7.9V 7.9V 7.9V 7.9V 12V	8 7.9V 7.9V 7.9V 7.9V 12V	8 7.9V 7.9V 7.9V 7.9V 12V	8 7.9V 7.9V 7.9V 7.9V 12V

IC213	IC218
1 0~4.9V	0~4.9V
2 -4.9~4.9V	-4.9~4.9V
3 -12.8V	-12.8V
4 -4.9~4.9V	-4.9~4.9V
5 12V	12V

IC202	IC209	IC211	IC212
1 -4.9V 25 -4.9V	1 2.5V	1 2.5V	1 2.5V
2 -4.9V 26 0V	2 2.3V	2 2.3V	2 2.3V
3 0V 27 -	3 4.9V	3 4.9V	3 4.9V
4 0V 28 5V	4 4.9V	4 4.9V	4 4.9V
5 0V 29 0V	5 -	5 -	5 -
6 0V 30 5V	6 2.6V	6 2.6V	6 2.6V
7 0V 31 5V	7 2.6V	7 2.6V	7 2.6V
8 0V 32 0V	8 0V	8 2.3V	8 2.3V
9 0V 33 2.4V	9 2V	9 5V	9 5V
10 0V 34 2.5V	10 4.9V	10 2V	10 2V
11 1V 35 2.3V	11 -	11 3.1V	11 3.1V
12 0V 36 2.3V	12 -	12 0V	12 0V
13 0.3V 37 3.5V	13 -	13 0V	13 0V
14 0V 38 2.5V	14 4.7V	14 0V	14 0V
15 0V 39 4.9V	15 4.9V	15 0V	15 0V
16 4.9V 40 2.5V	16 4.9V	16 0V	16 0V
17 0V 41 4.8V	17 4.9V	17 -7.8V	17 -7.8V
18 -3.2V 42 2.5V	18 4.9V	18 0V	18 0V
19 0V 43 4.9V	19 4.9V	19 4.9V	19 4.9V
20 *1 44 0V	20 -	20 -	20 -
21 0V 45 1.1V	21 0V	21 -	21 -
22 -4.9V 46 2.4V	22 4.9V	22 -	22 -
23 -4.9V 47 0V	23 2.1V	23 3.4V	23 3.4V
24 4.8V 48 0V	24 2.1V	24 1.9V	24 1.9V
	25 3.7V	25 3.7V	25 3.7V
	26 1.9V	26 2V	26 2V
	27 -4.9V	27 0V	27 0V
	28 2.5V	28 -7.8V	28 -7.8V

## FL/Key Board P.C. Board

## FADE P.C. Board

## REMOTE P.C. Board

## PREHEAT P.C. Board

## POWER SUPPLY P.C. Board

## PICK UP ASS'Y MECHA

## TUBE 2 P.C. Board

## FL301 FV335G

## IC105 REGULATOR

## IC102 M5238P

## IC101 M5238P

## IC101 M5238P

## IC101 M5238P

## IC101 M5238P

## IC101 M5238P

## IC101 M5238P

## IC101 M5238P

## IC101 M5238P

## IC101 M5238P

## IC101 M5238P

## IC101 M5238P

## IC101 M5238P

## IC101 M5238P

## IC101 M5238P

## IC101 M5238P

## IC101 M5238P

## IC101 M5238P

## IC101 M5238P

## IC101 M5238P

## IC101 M5238P

## IC101 M5238P

## IC101 M5238P

## IC101 M5238P

## IC101 M5238P

## IC101 M5238P

## IC101 M5238P

## IC101 M5238P

## IC101 M5238P

## IC101 M5238P

## IC101 M5238P

## IC101 M5238P

## IC101 M5238P

## IC101 M5238P

## IC101 M5238P

## IC101 M5238P

## IC101 M5238P

## IC101 M5238P

## IC101 M5238P

## IC101 M5238P

## IC101 M5238P

## IC101 M5238P

## IC101 M5238P

## IC101 M5238P

## IC101 M5238P

## IC101 M5238P

## IC101 M5238P

## IC101 M5238P

## IC101 M5238P

## IC101 M5238P

## IC101 M5238P

## IC101 M5238P

## IC101 M5238P

## IC101 M5238P

## IC101 M5238P

## IC101 M5238P

## IC101 M5238P

## IC101 M5238P

## IC101 M5238P

## IC101 M5238P

## IC101 M5238P

## IC101 M5238P

## IC101 M5238P

## IC101 M5238P

## IC101 M5238P

## IC101 M5238P

## IC101 M5238P

## IC101 M5238P

## IC101 M5238P

## IC101 M5238P

## IC101 M5238P

## IC101 M5238P

## IC101 M5238P

## IC101 M5238P

## IC101 M5238P

## IC101 M5238P





# Schematic Diagram <D-105U AD/UZ/AG/UQ> (2/2)

IC'S	IC213	IC203 IC204	IC214 IC215	IC202 IC216 IC217	IC201	IC208	IC207
TRANSISTORS (Q)	Q220		Q212 Q213		Q233	Q224 Q226 Q225	Q204 Q201

1 MAIN P.C. Board

2 TO PICK UP

3 TO CH302 FL/KEY BOARD P.C. Board

4 TO CH501 REMOTE P.C. Board  
TO CH101 POWER SUPPLY P.C. Board  
TO ASS'Y MECH

5 TO PICK UP

TO CH102 POWER SUPPLY P.C. Board

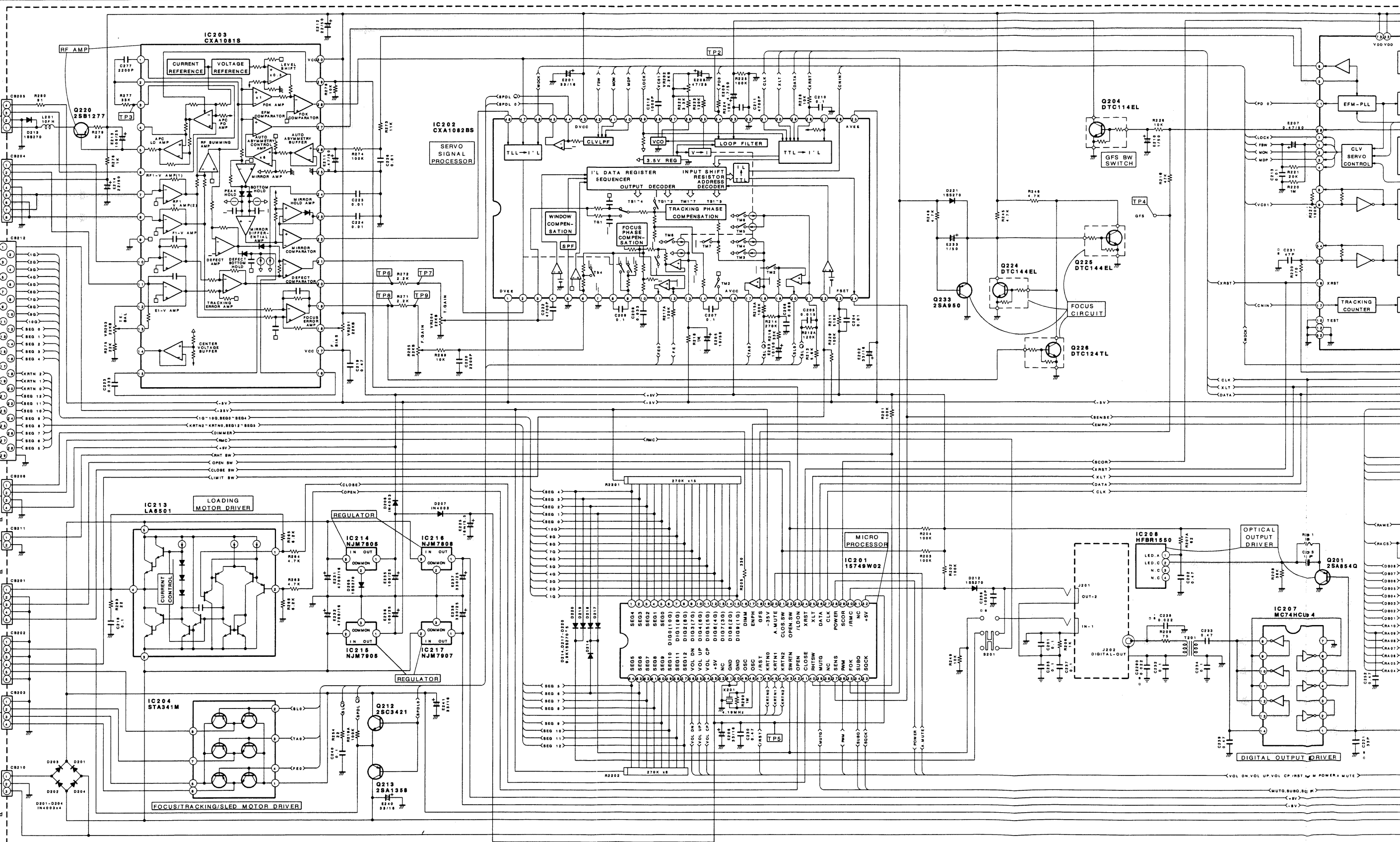

A I B I C I D I E I F I G I H I



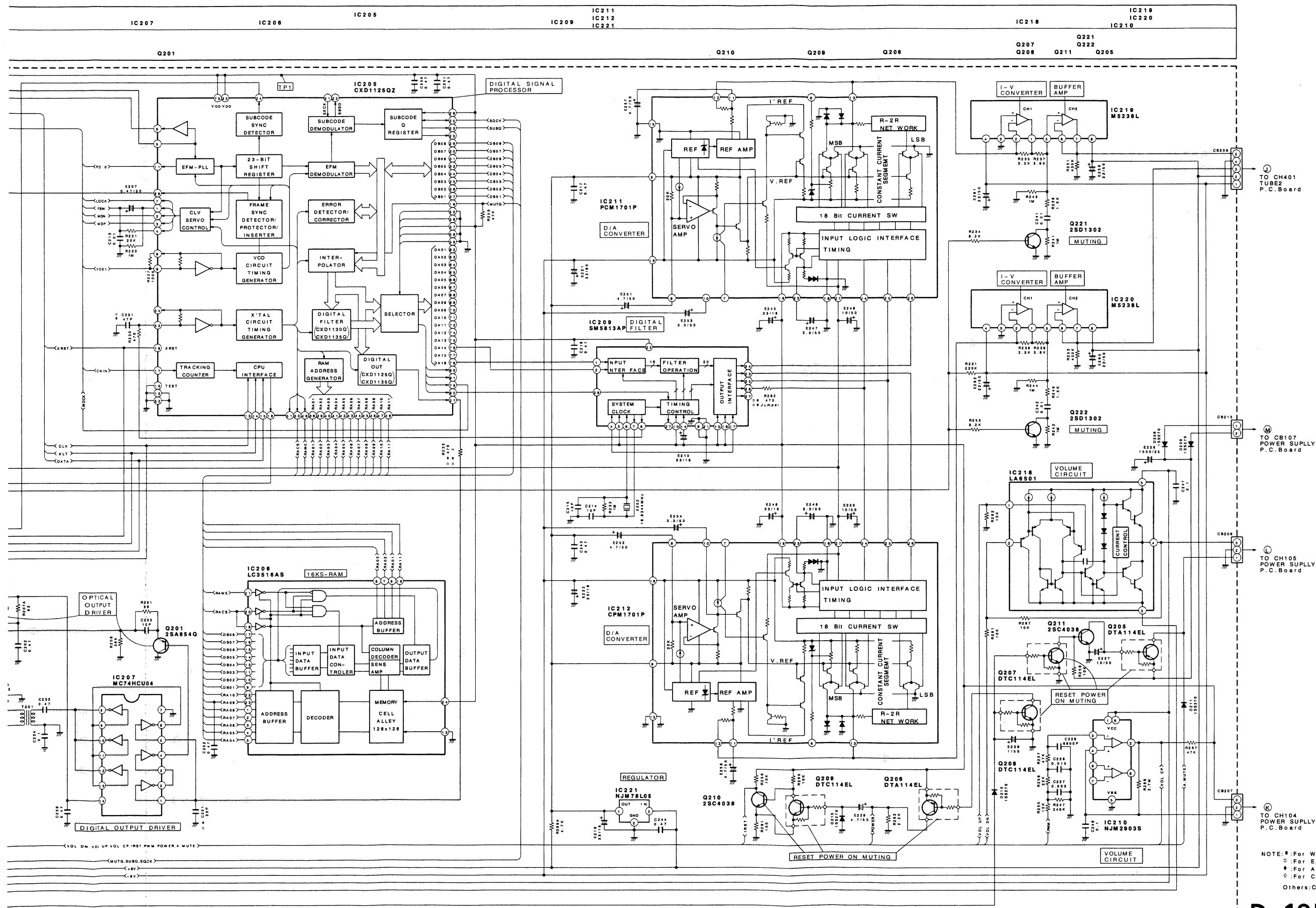

**D-105U**

NOTE: For West German model only (AD)  
 □ For England model only (AG)  
 ♦ For American model only (UZ)  
 ○ For Canadian model only (UQ)  
 Others: Common

# Schematic Diagram <D-105U JA/EK> (2/2)

IC'S	IC213	IC203	IC214	IC215	IC202	IC201	IC204	IC208	IC207	IC206
TRANSISTORS (Q)	Q220	Q218 Q219	Q216 Q217	Q214 Q215	Q212 Q213		Q204		Q201	

1 MAIN P.C. Board

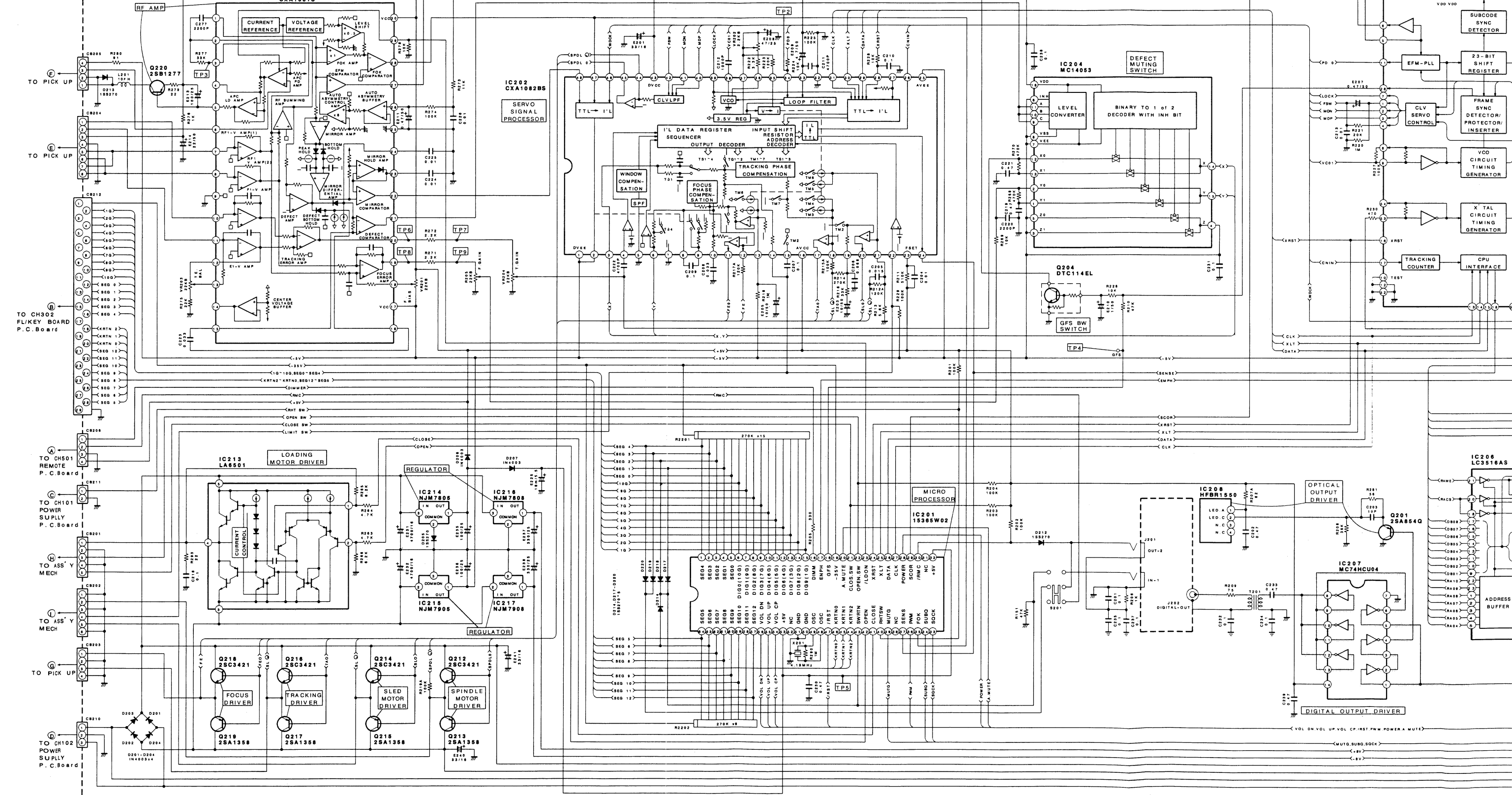

A | B | C | D | E | F | G | H | I

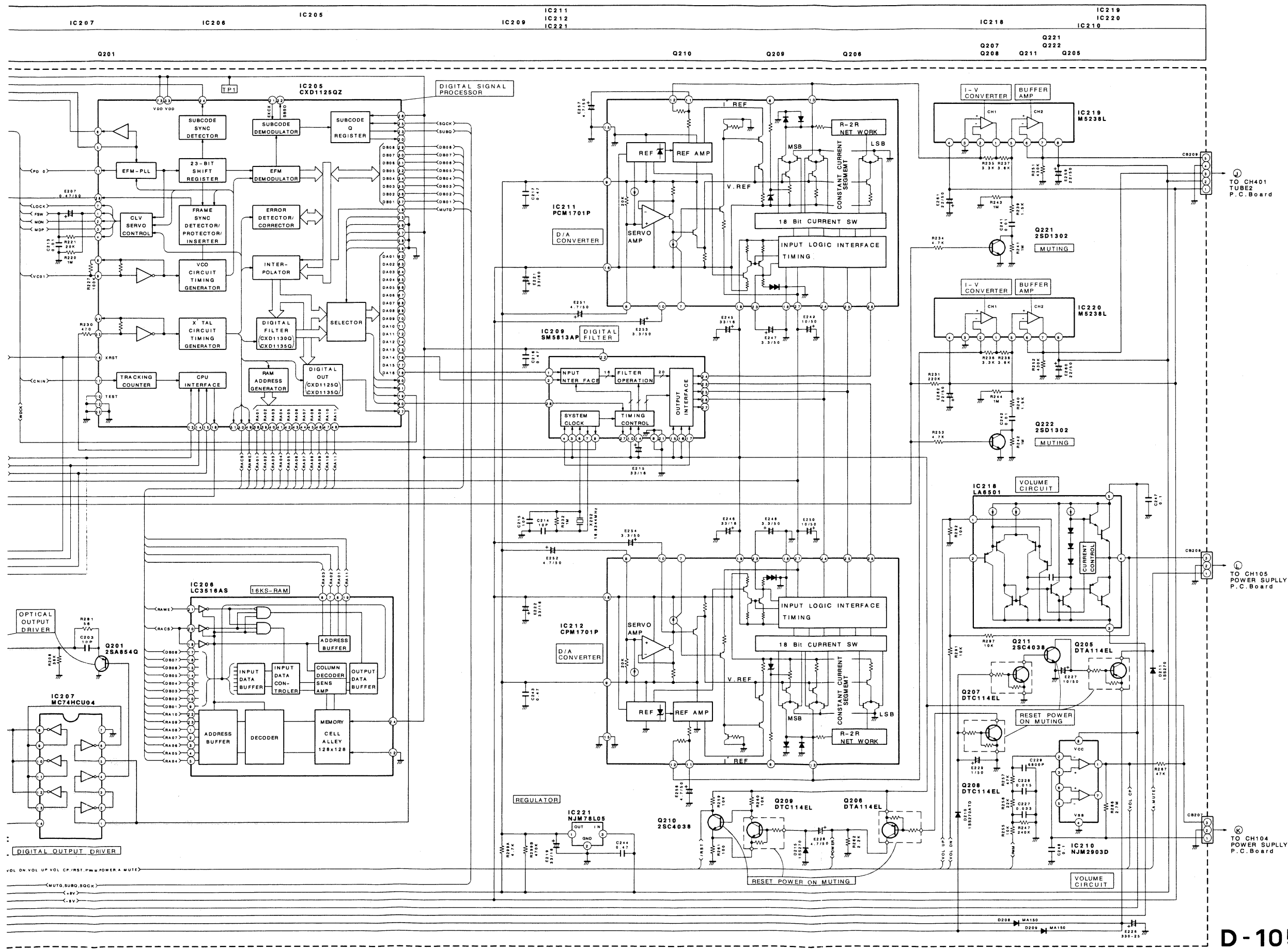

D-105U

# Parts Layout on P.C. Boards and Wiring Diagram (AD/UZ/AG/UQ model)

- BLU.....Blue
- GRN.....Green
- BLK.....Black
- GRY.....Gray
- WHT.....White
- RED.....Red
- BRN.....Brown
- ORG.....Orange
- YEL.....Yellow
- VIO.....Violet
- PNK.....Pink
- GRN/WHT.....Green/White
- GRY/WHT.....Gray/White
- GRY/YEL.....Gray/Yellow
- GRN/YEL.....Green/Yellow
- SHLD....Shield

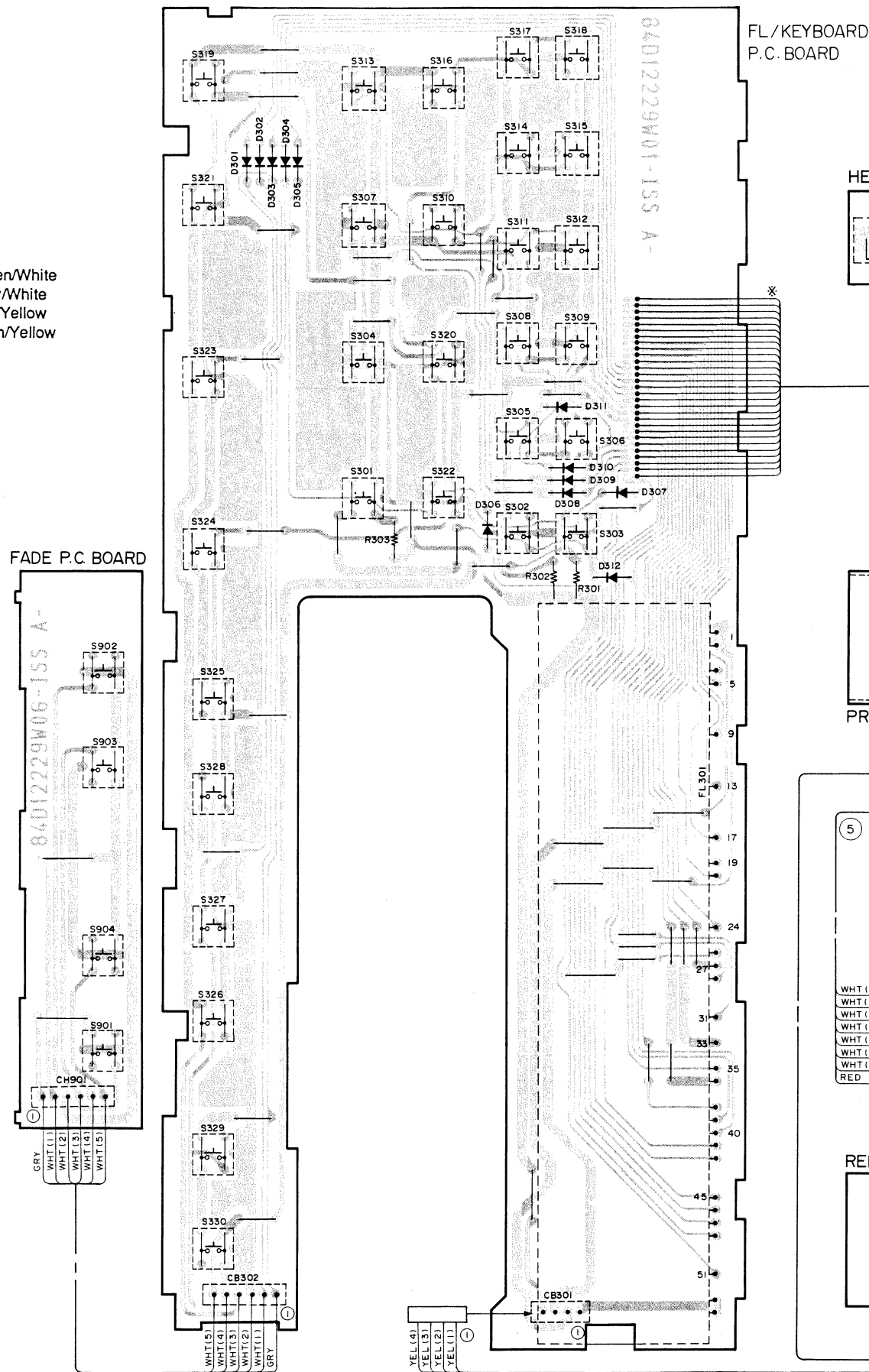

FADE P.C. BOARD

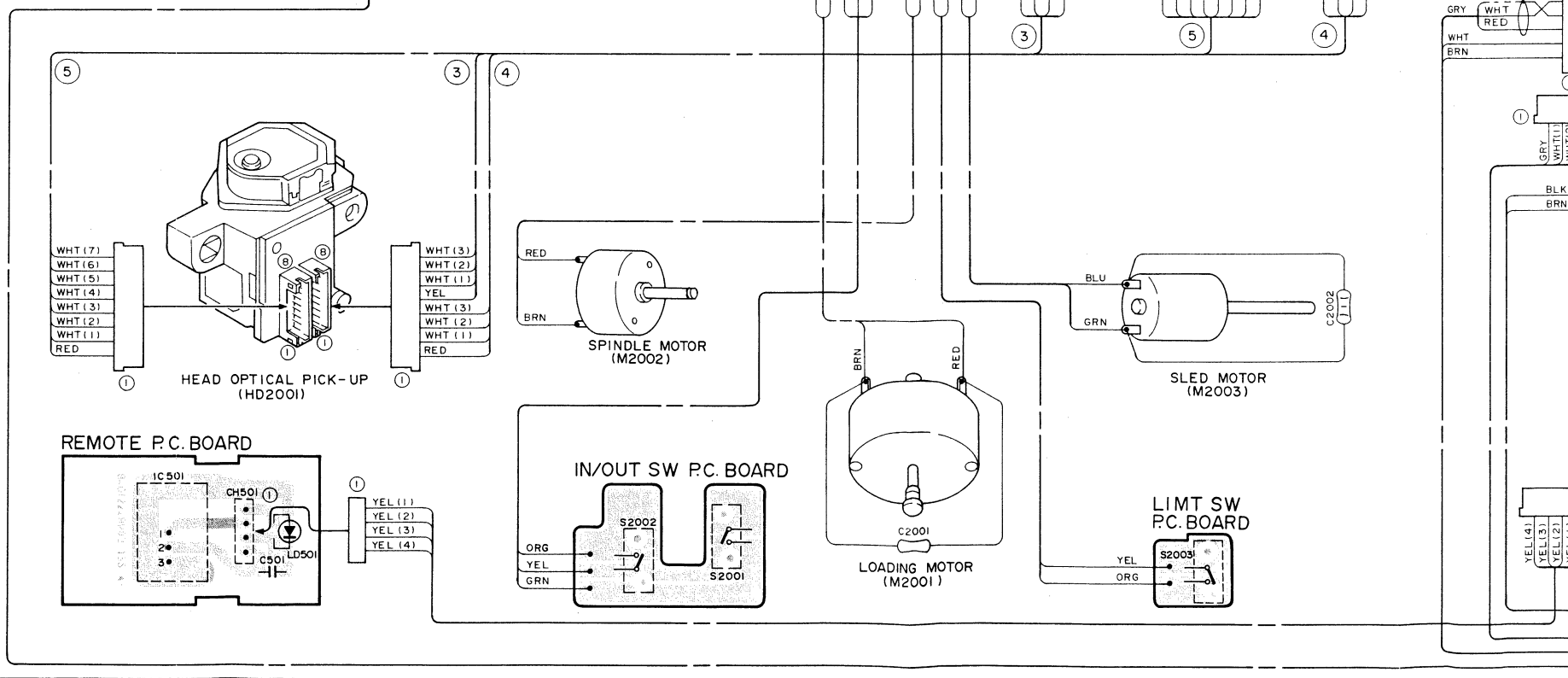
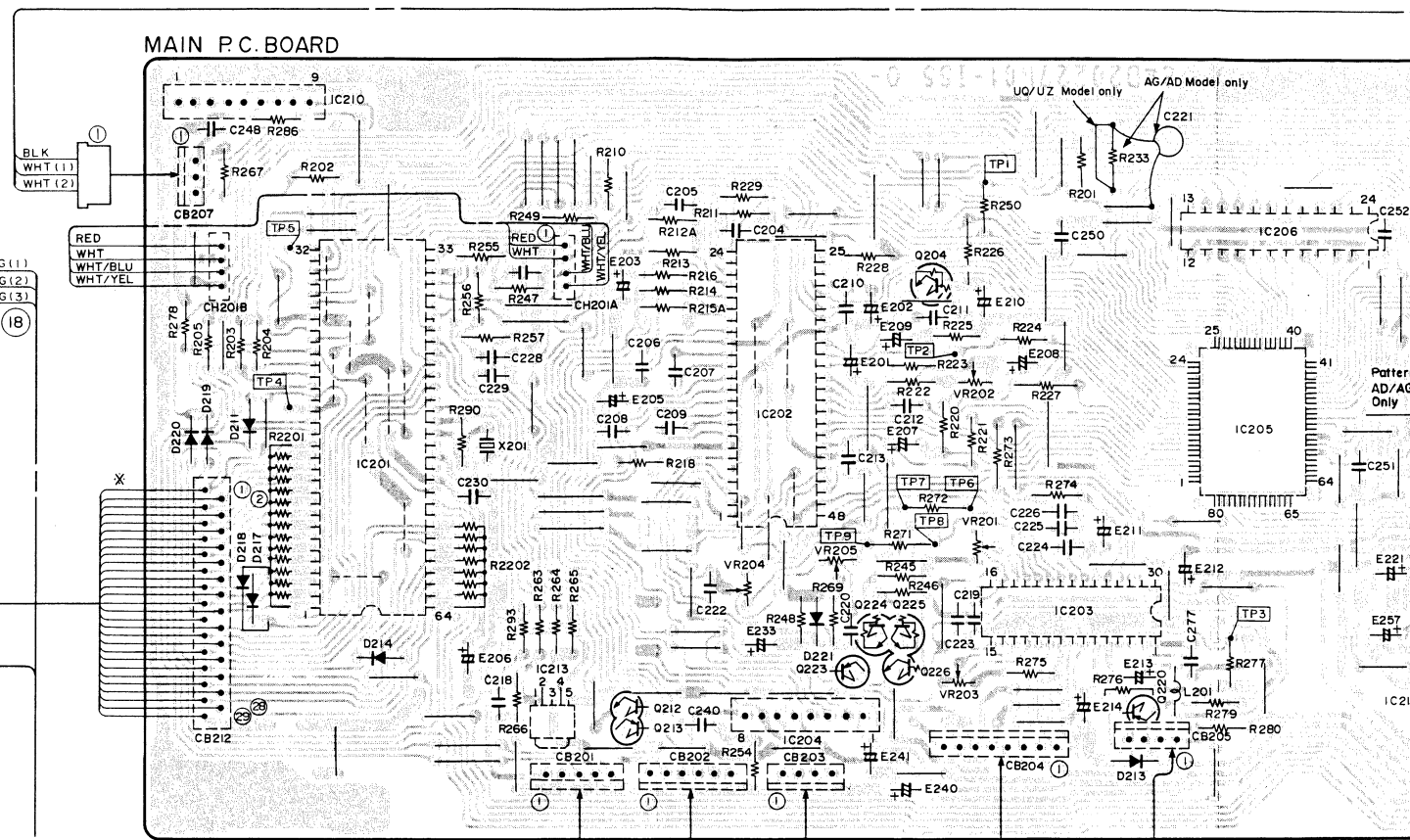
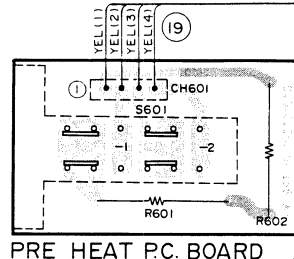
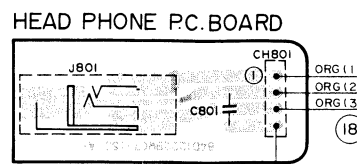
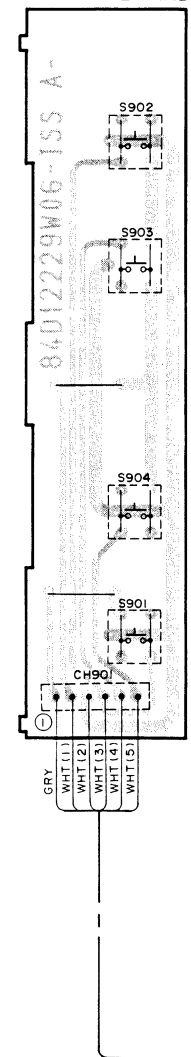



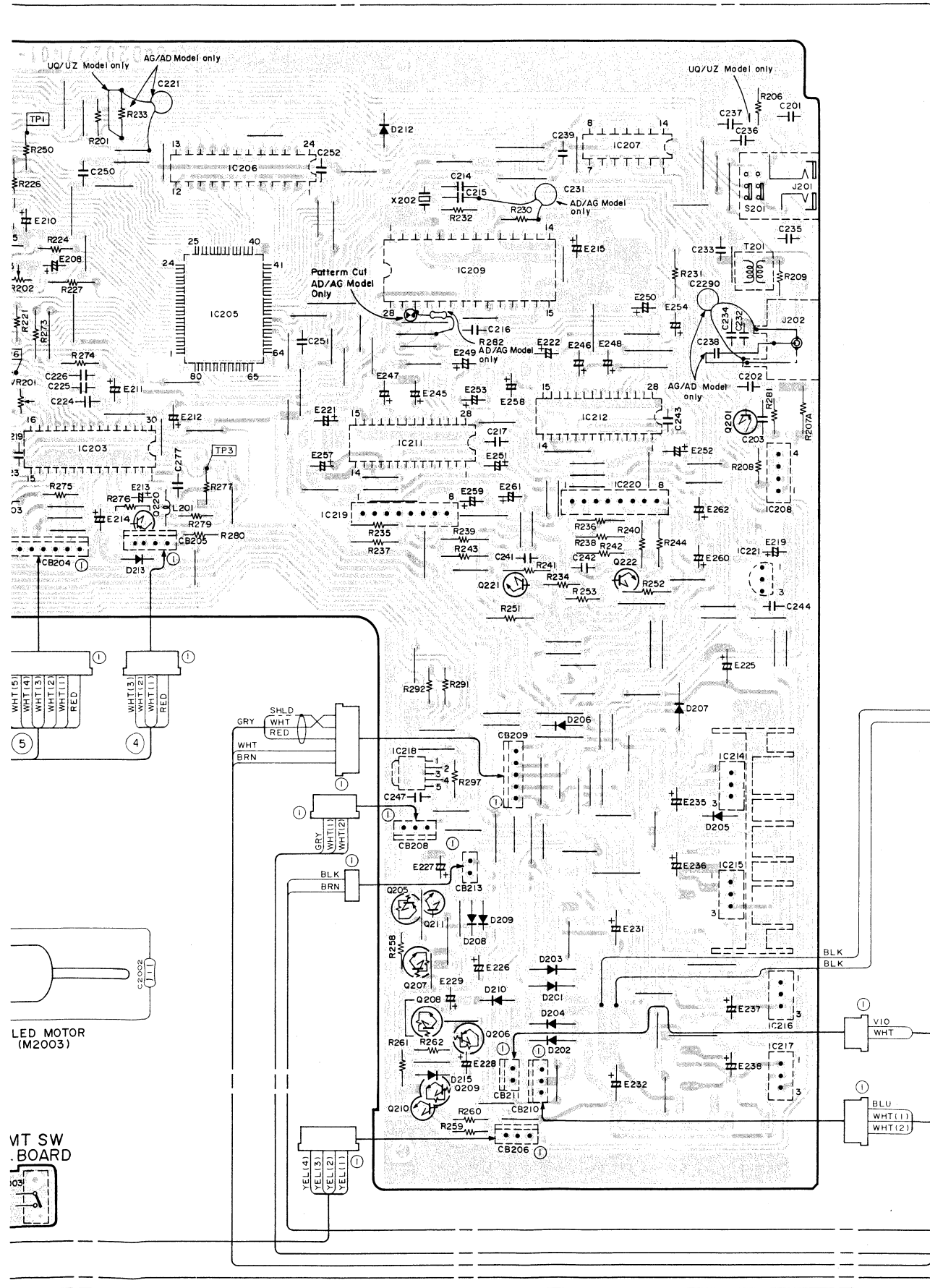

POWER SUPPLY P.C. BOARD

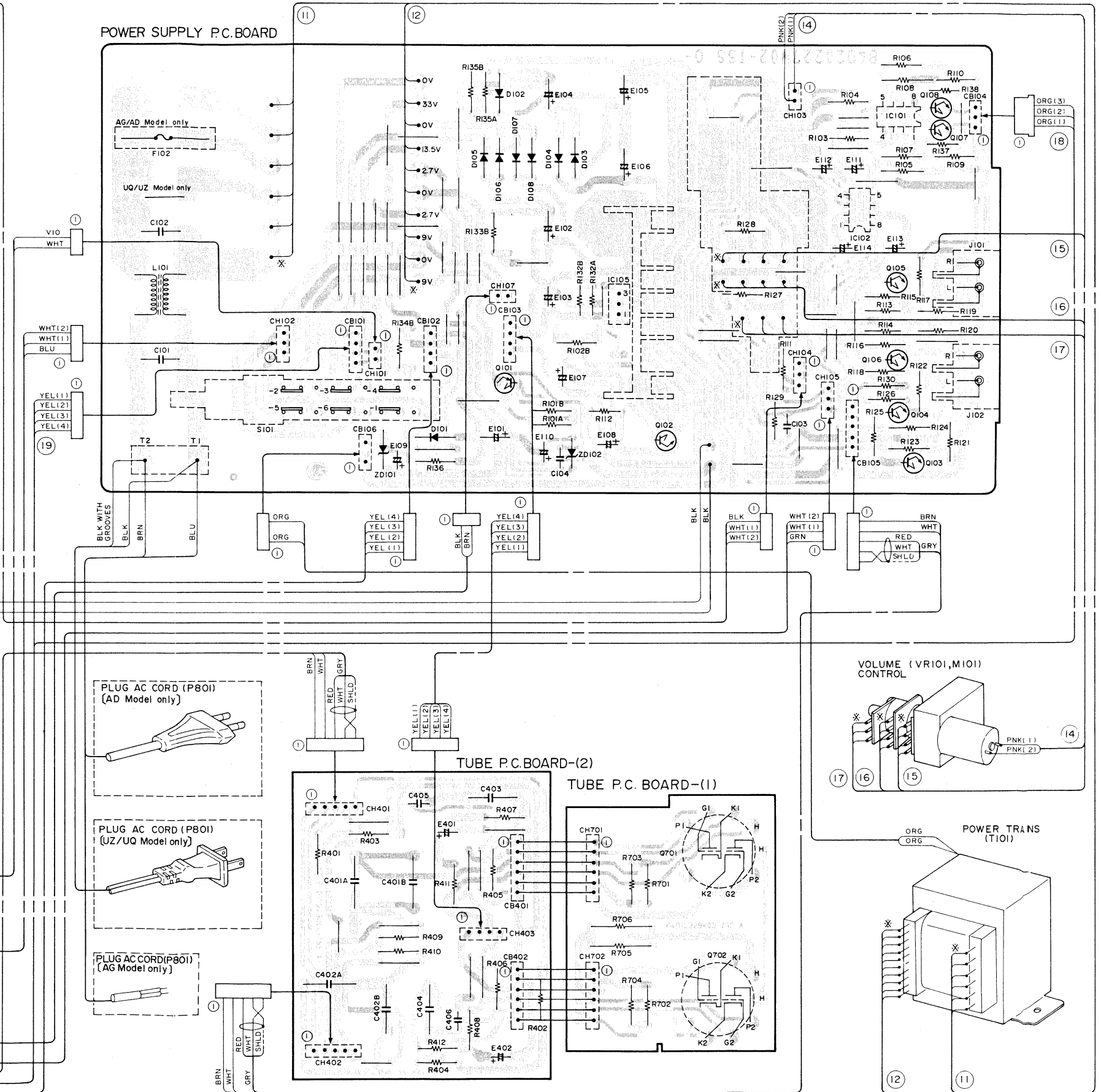

# Parts Layout on P.C. Board and Wiring Diagram (JA/EK model)

- BLU.....Blue
- GRN.....Green
- BLK.....Black
- GRY.....Gray
- WHT.....White
- RED.....Red
- BRN.....Brown
- ORG.....Orange
- YEL.....Yellow
- VIO.....Violet
- PNK.....Pink
- GRN/WHT.....Green/White
- GRY/WHT.....Gray/White
- GRY/YEL.....Gray/Yellow
- GRN/TEL.....Green/Yellow
- SHLD....Shield

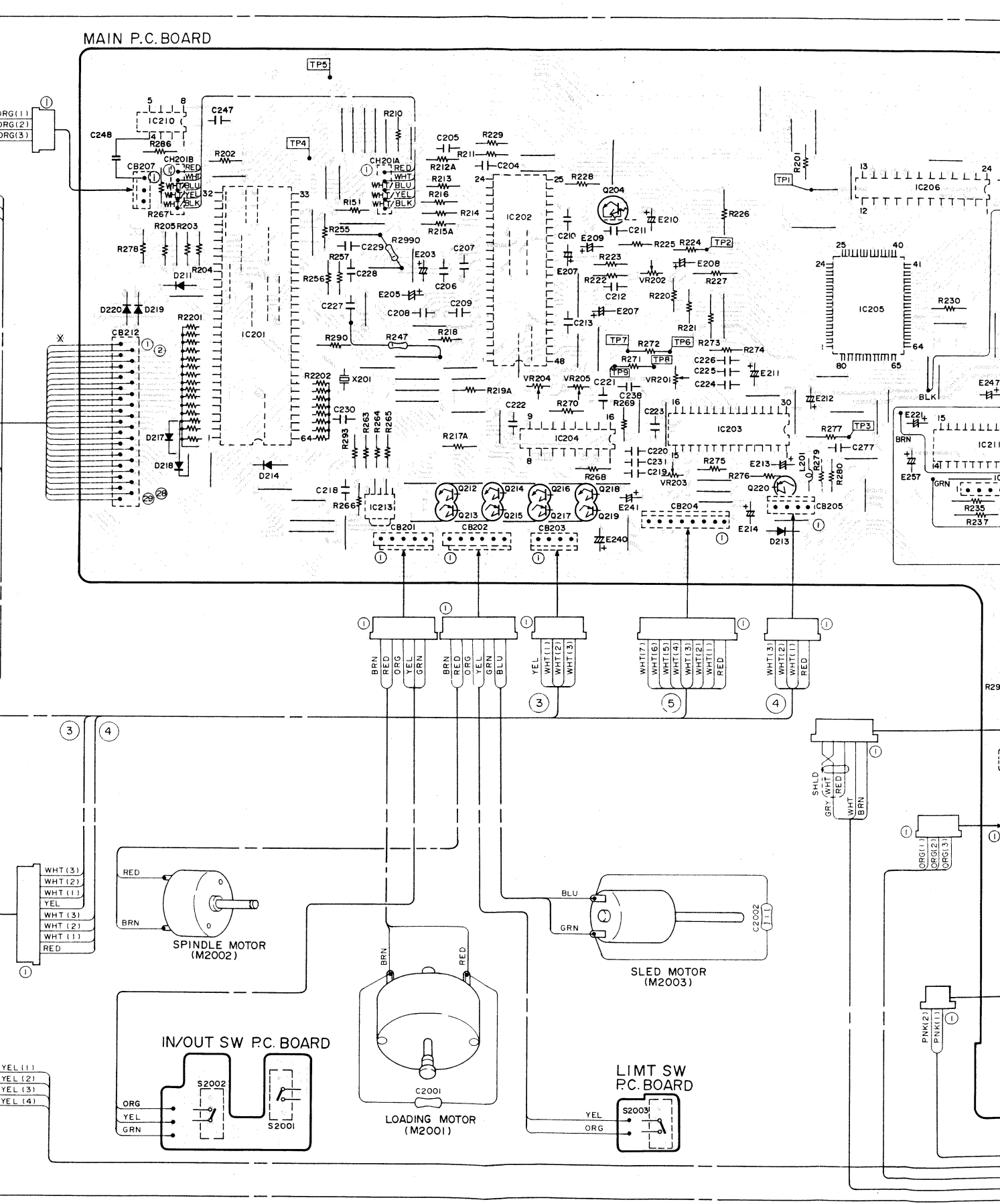
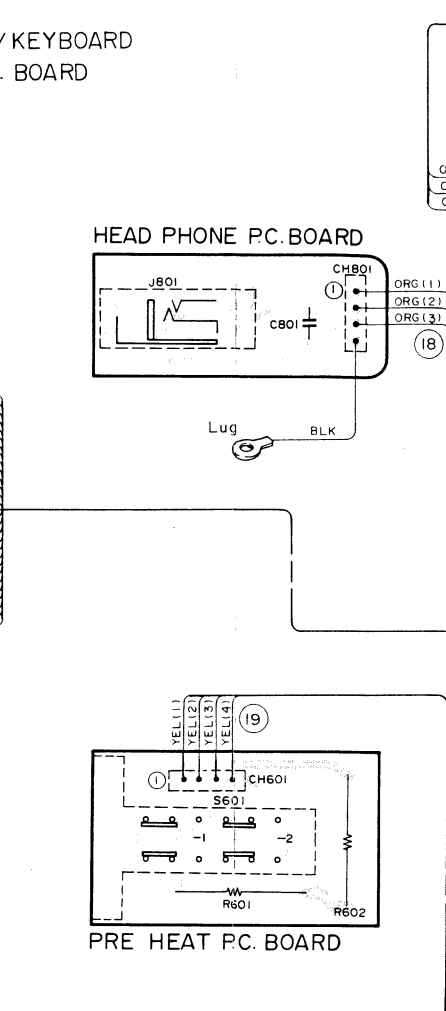
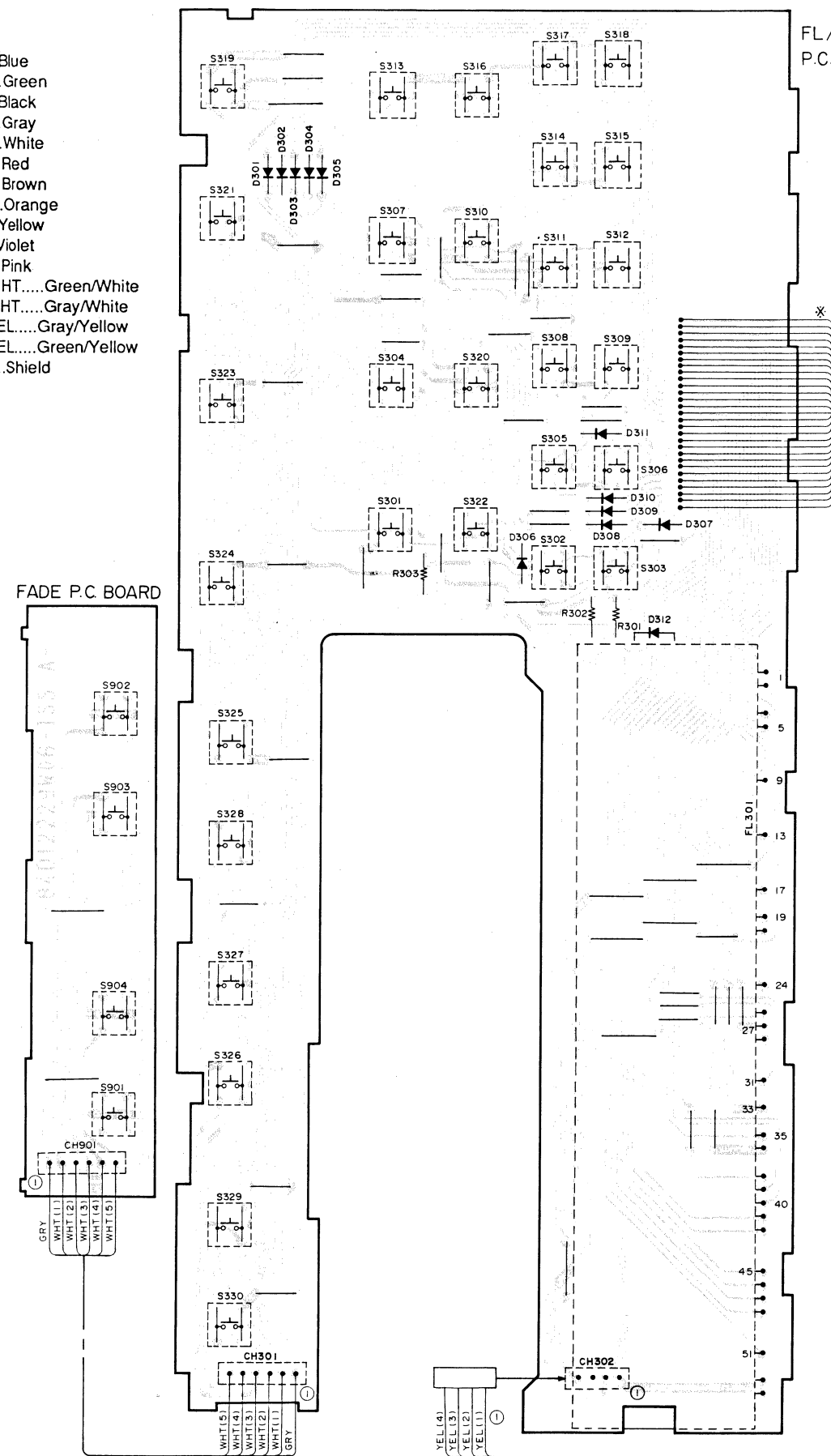

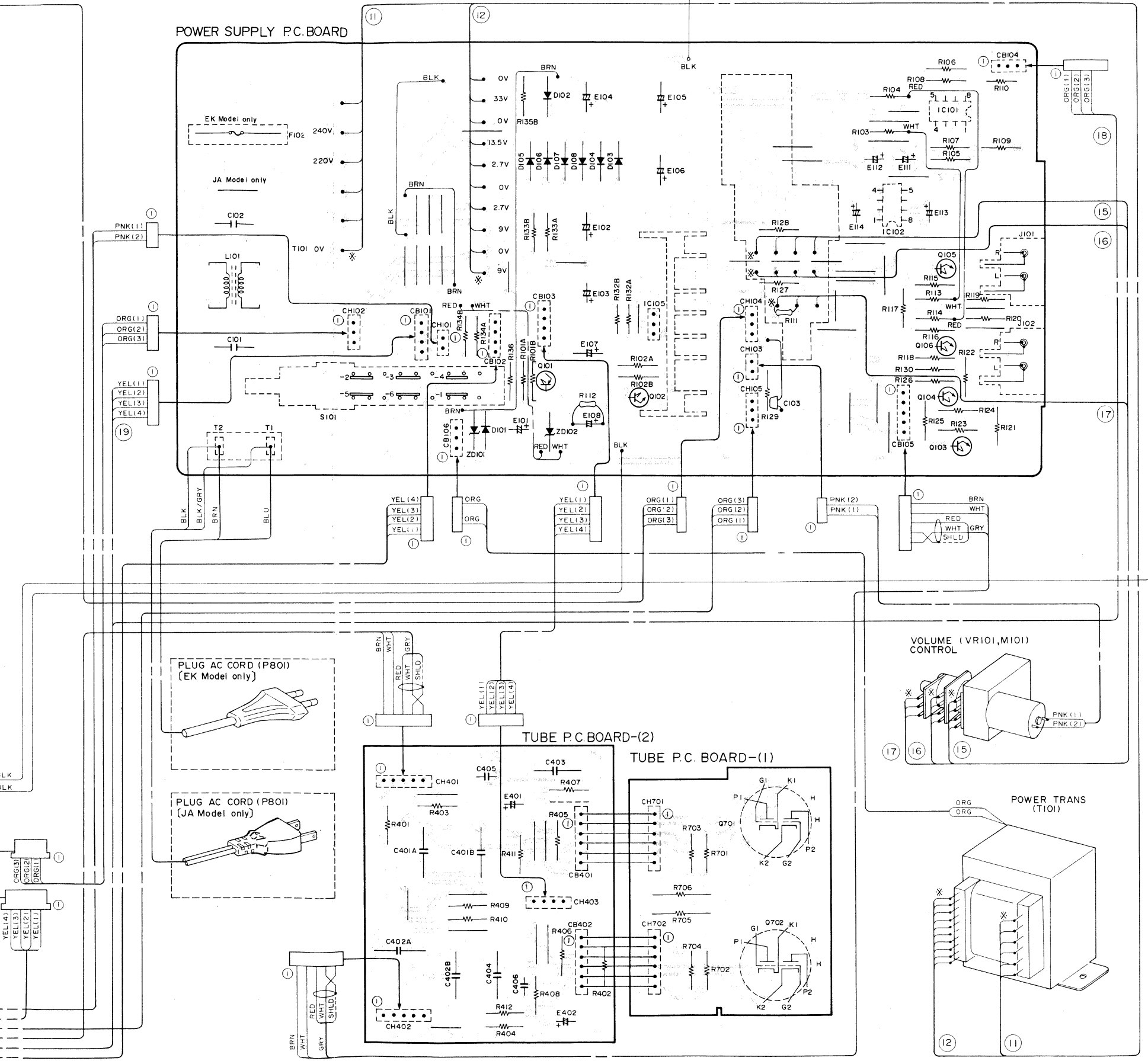
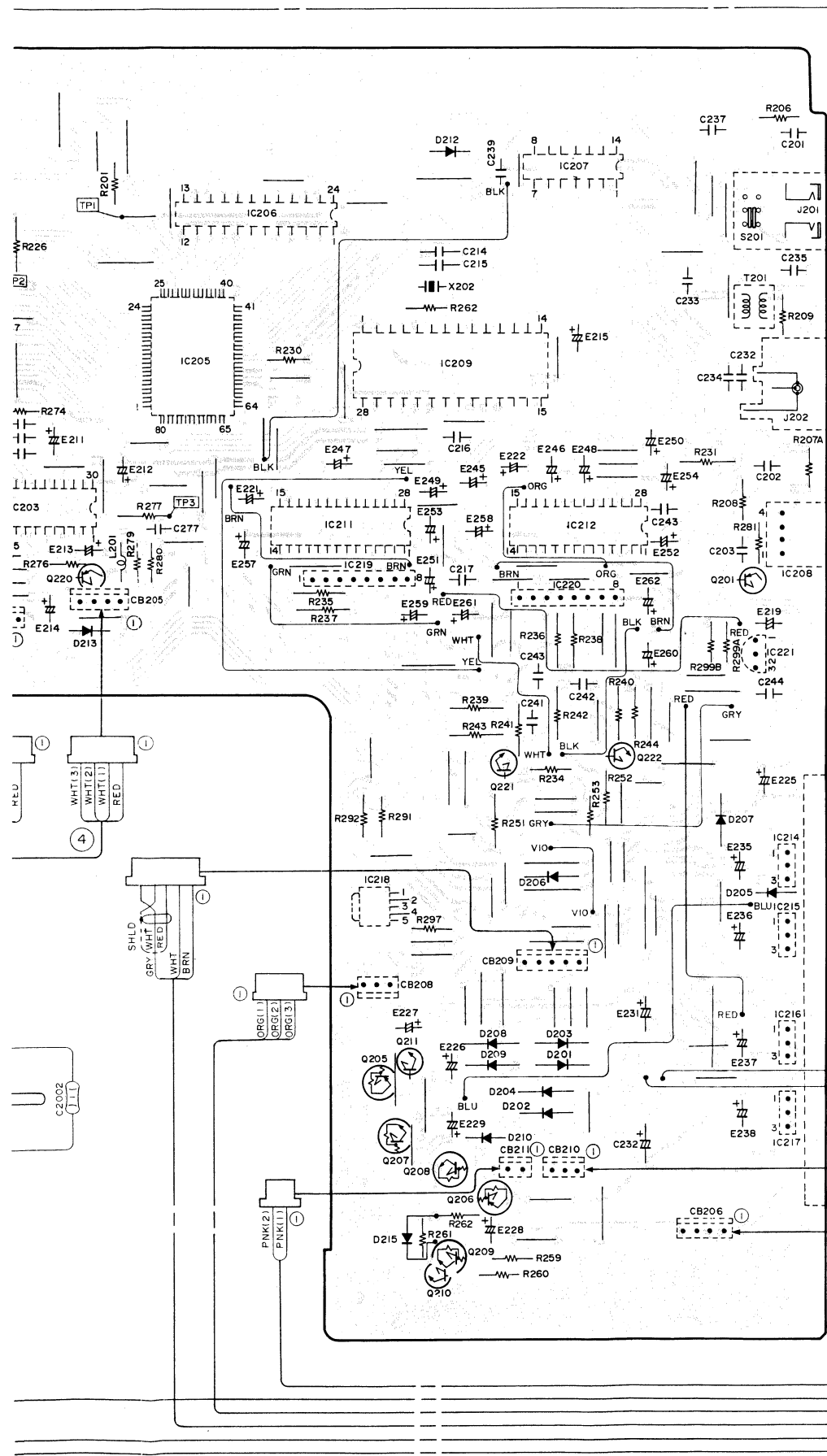

# Electrical Parts List

Resistor: Carbon resistors under 1/8 watts are not mentioned in the parts list, please confirm them by schematic diagram.  
 Capacitor:  $\mu$ F-microfarads, pF-picofarads.

Abbreviations			
Cap.-Capacitor		CER.-Ceramic	
CP.-Chip		ELY.-Electrolytic	
LED.-Light Emitting Diode		MIC.-Mica	
MO.-Metal Oxide Film		MYL.-Mylar	
PP.-Polypropylene		SOL.-Solid	
TAN.-Tantalum		ZEN.-Zenner	

Symbol No	Part No	Description		
Main P.C. Board				
IC's				
●	IC201	51T15365W02	15365W02	
▲	IC201	51T15365W02	15365W02	
◆	IC201	51T15749W02	15749W02	
◇	IC201	51T15749W02	15749W02	
■	IC201	51T15749W02	15749W02	
□	IC201	51T15749W02	15749W02	
	IC202	51T84722F02	CXA1082BS	
	IC203	51T84721F01	CXA1081S	
●	IC204	51T94886F01	MC14053	
▲	IC204	51T94886F01	MC14053	
◆	IC204	51T25098W01	STA341M	
◇	IC204	51T25098W01	STA341M	
■	IC204	51T25098W01	STA341M	
□	IC204	51T25098W01	STA341M	
	IC205	51T84720F01	CXD1125QZ	
	or	51T84719F01	CXD1135QZ	
	IC206	51T84723F01	LC3516AS	
	IC207	51T94890F01	MC74HCU04	
	IC208	51T15608W01	HFBR1550	
	IC209	51T15628W01	SM5813AP	
●	IC210	51T64227F01	NJM2903D	
▲	IC210	51T64227F01	NJM2903D	
◆	IC210	51T62866F01	NJM2903S	
◇	IC210	51T62866F01	NJM2903S	
■	IC210	51T62866F01	NJM2903S	
□	IC210	51T62866F01	NJM2903S	
	IC211	51T16104W01	PCM1701P	
	IC212	51T16104W01	PCM1701P	
	IC213	51T90889F01	LA6501	
	IC214	51T80338F01	NJM7805	
	IC215	51T80339F01	NJM7905	

Symbol No	Part No	Description		
●	IC216	51T15976W01	NJM7808	
▲	IC216	51T15976W01	NJM7808	
◆	IC216	51T15121W02	NJM7808FA	
◇	IC216	51T15121W02	NJM7808FA	
■	IC216	51T15121W02	NJM7808FA	
□	IC216	51T15121W02	NJM7808FA	
	IC217	51T15977W01	NJM7908	
	IC218	51T90889F01	LA6501	
	IC219	51T80136F02	M5238L	
	IC220	51T80136F02	M5238L	
	IC221	51T60969F01	NJM78L05-A	
Transistors				
	Q201	48T73682F01	2SA854Q	
	Q204	48T82763F02	DTC114EL	
	Q205	48T82762F02	DTA114EL	
	Q206	48T82762F02	DTA114EL	
	Q207	48T82763F02	DTC114EL	
	Q208	48T82763F02	DTC114EL	
	Q209	48T82763F02	DTC114EL	
	Q210	48T82758F01	2SC4038	
	Q211	48T82758F01	2SC4038	
	Q212	48T69176F01	2SC3421	
	Q213	48T69177F01	2SA1358	
●	Q214	48T69176F01	2SC3421	
▲	Q214	48T69176F01	2SC3421	
●	Q215	48T69177F01	2SA1358	
▲	Q215	48T69177F01	2SA1358	
●	Q216	48T69176F01	2SC3421	
▲	Q216	48T69176F01	2SC3421	
●	Q217	48T69177F01	2SA1358	
▲	Q217	48T69177F01	2SA1358	
●	Q218	48T69176F01	2SC3421	
▲	Q218	48T69176F01	2SC3421	
●	Q219	48T69177F01	2SA1358	
▲	Q219	48T69177F01	2SA1358	
	Q220	48T82759F01	2SB1277	
	Q221	48T57305F04	2SD1302	
	Q222	48T57305F04	2SD1302	
◆	Q223	48T43526F02	2SA950	
◇	Q223	48T43526F02	2SA950	
■	Q223	48T43526F02	2SA950	
□	Q223	48T43526F02	2SA950	
◆	Q224	48T82763F04	DTC114EL	
◇	Q224	48T82763F04	DTC114EL	

Note: ●:For Japanese model only (JA)  
 ▲:For General Foreign model only (EK)  
 others:Common

◆:For American model only (UZ)  
 ■:For West Germany model only (4D)  
 ◇:For Canadian model only (UQ)  
 □:For England model only (AG)



Symbol No	Part No	Description		
■	Q224	48T82763F04	DTC114EL	
□	Q224	48T82763F04	DTC114EL	
◆	Q225	48T82763F04	DTC114EL	
◇	Q225	48T82763F04	DTC114EL	
■	Q225	48T82763F04	DTC114EL	
□	Q225	48T82763F04	DTC114EL	
◆	Q226	48T82763F11	DTC124TL	
◇	Q226	48T82763F11	DTC124TL	
■	Q226	48T82763F11	DTC124TL	
□	Q226	48T82763F11	DTC124TL	
Diodes				
	D201	48S40477U01	1N4003	
	D202	48S40477U01	1N4003	
	D203	48S40477U01	1N4003	
	D204	48S40477U01	1N4003	
	D205	48T84758F01	1SS270ATD	
	D206	48S40477U01	1N4003	
	D207	48S40477U01	1N4003	
●	D208	48T51582F01	MA150	
▲	D208	48T51582F01	MA150	
◆	D208	48T84758F01	1SS270	
◇	D208	48T84758F01	1SS270	
■	D208	48T84758F01	1SS270	
□	D208	48T84758F01	1SS270	
●	D209	48T51582F01	MA150	
▲	D209	48T51582F01	MA150	
◆	D209	48T84758F01	1SS270	
◇	D209	48T84758F01	1SS270	
■	D209	48T84758F01	1SS270	
□	D209	48T84758F01	1SS270	
	D210	48T84758F01	1SS270	
	D211	48T84758F01	1SS270	
	D212	48T84758F01	1SS270	
	D213	48T84758F01	1SS270	
	D214	48T84758F01	1SS270	
	D215	48T84758F01	1SS270	
	D217	48T84758F01	1SS270	
	D218	48T84758F01	1SS270	
	D219	48T84758F01	1SS270	
	D220	48T84758F01	1SS270	
◆	D221	48T84758F01	1SS270	
◇	D221	48T84758F01	1SS270	
■	D221	48T84758F01	1SS270	
□	D221	48T84758F01	1SS270	

Note:●:For Japanese model only (JA)

▲:For General Foreign model only (EK)

others:Common

Symbol No	Part No	Description		
Capacitors				
	C201	08T57298F01	CER.	0.1 $\mu$ F
	E201	23T00180L08	ELY.	33 $\mu$ F/16V
	C202	08T94422F01	CER.	0.47 $\mu$ F
◆	E202	23T00180L08	ELY	33 $\mu$ F/16V
◇	E202	23T00180L08	ELY	33 $\mu$ F/16V
■	E202	23T00180L08	ELY	33 $\mu$ F/16V
□	E202	23T00180L08	ELY	33 $\mu$ F/16V
◆	C203	08S55260F13	CER.	10pF
◇	C203	08S55260F13	CER.	10pF
■	C203	08S55260F13	CER.	10pF
□	C203	08S55260F13	CER.	10pF
●	C203	08S65480F13	CER.	10 $\mu$ F
▲	C203	08S65480F13	CER.	10 $\mu$ F
	E203	23T00180L25	ELY.	10 $\mu$ F/50V
	C204	08T57705F67	MYL.	0.01 $\mu$ F
	C205	08T57705F69	MYL.	0.015 $\mu$ F
	E205	23T00180L25	MYL.	10 $\mu$ F/50V
	C206	08T57851F11	TF.	0.068 $\mu$ F
◆	E206	23T00180L08	ELY,	33 $\mu$ F/16V
◇	E206	23T00180L08	ELY,	33 $\mu$ F/16V
■	E206	23T00180L08	ELY,	33 $\mu$ F/16V
□	E206	23T00180L08	ELY,	33 $\mu$ F/16V
	C207	08T57851F13	TF.	0.1 $\mu$ F
	E207	23T00180L20	ELY.	0.47 $\mu$ F/50V
	C208	08T57705F73	MYL.	0.033 $\mu$ F
	E208	23T00180L13	ELY.	47 $\mu$ F/25V
	C209	08T57851F13	TF.	0.1 $\mu$ F
	E209	23T00180L24	ELY.	4.7 $\mu$ F/50V
	C210	08T57851F13	TF.	0.1 $\mu$ F
	E210	23T00180L21	ELY.	1 $\mu$ F/50V
	C211	08T57705F63	MYL.	4700pF
	E211	23T00180L20	ELY.	0.47 $\mu$ F/50V
	C212	08T57705F55	MYL.	1000pF
	E212	23T00180L26	ELY.	22 $\mu$ F/50V
	C213	08T57705F67	MYL.	0.01 $\mu$ F
	E213	23T00180L14	ELY.	100 $\mu$ F/25V
	C214	08T55260F13	CER.	10pF
	E214	23T00180L26	ELY.	22 $\mu$ F/50V
	C215	08T55260F13	CER.	10pF
	E215	23T00180L08	ELY.	33 $\mu$ F/16V
	C216	08T94422F01	CER.	0.47 $\mu$ F
	C217	08T94422F01	CER.	0.47 $\mu$ F
	C218	08T57851F13	TF.	0.1 $\mu$ F
●	C219	08T57851F21	TF.	0.47 $\mu$ F
▲	C219	08T57851F21	TF.	0.47 $\mu$ F

◆:For American model only (UZ)

■:For West Germany model only (AD)

◇:For Canadian model only (UQ),

□:For England model only (AG),

Symbol No	Part No	Description		
◆	C219	08T94422F01	CER.	0.47 $\mu$ F
◇	C219	08T94422F01	CER.	0.47 $\mu$ F
■	C219	08T94422F01	CER.	0.47 $\mu$ F
□	C219	08T94422F01	CER.	0.47 $\mu$ F
	E219	23T00180L08	ELY.	33 $\mu$ F/16V
	C220	08T57705F59	MYL.	2200pF
●	C221	08T57851F21	TF.	0.47 $\mu$ F
▲	C221	08T57851F21	TF.	0.47 $\mu$ F
■	C221	21C45322G16	CER.	33pF
□	E221	23T00180L08	ELY.	33 $\mu$ F/16V
	C222	08T57705F63	MYL.	4700pF
	E222	23T00180L08	ELY.	33 $\mu$ F/16V
	C223	08T57705F73	MYL.	0.033 $\mu$ F
	C224	08T57705F67	MYL.,	0.01 $\mu$ F
	C225	08T57705F67	MYL.	0.01 $\mu$ F
	E225	23T74513F06	ELY.	18mF/5.5V
	C226	08T57705F67	MYL.	0.01 $\mu$ F
●	E226	23T00180L16	ELY.	330 $\mu$ F/25V
▲	E226	23T00180L16	ELY.	330 $\mu$ F/25V
◆	E226	23T00134L46	ELY,	1000 $\mu$ F/25V
◇	E226	23T00134L46	ELY,	1000 $\mu$ F/25V
■	E226	23T00134L46	ELY,	1000 $\mu$ F/25V
□	E226	23T00134L46	ELY,	1000 $\mu$ F/25V
	C227	08T57705F73	MYL.	0.033 $\mu$ F
	E227	23T00180L25	ELY.	10 $\mu$ F/50V
	C228	08T57705F69	MYL.	0.015 $\mu$ F
	E228	23T00180L24	ELY.	4.7 $\mu$ F/50V
	C229	08T57705F65	MYL.	6800pF
	E229	23T00180L21	ELY.	1 $\mu$ F/50V
	C230	08T94422F01	CER.	0.47 $\mu$ F
●	C231	08T57298F01	CER.	0.1 $\mu$ F
▲	C231	08T57298F01	CER.	0.1 $\mu$ F
■	C231	21C45322G18	CER.	47pF
□	C231	21C45322G18	CER.	47pF
	E231	23T00133L12	ELY.	4700 $\mu$ F/16V
	C232	08T57298F01	CER.	0.1 $\mu$ F
	E232	23T00133L12	ELY.	4700 $\mu$ F/16V
	C233	08T94422F01	CER.	0.47 $\mu$ F
	C234	08T57298F01	CER.	0.1 $\mu$ F
◆	E233	23T00180L21	ELY.	10 $\mu$ F/50V
◇	E233	23T00180L21	ELY.	10 $\mu$ F/50V
■	E233	23T00180L21	ELY.	10 $\mu$ F/50V
□	E233	23T00180L21	ELY.	10 $\mu$ F/50V
	C235	08T57298F01	CER.	0.1 $\mu$ F
	E235	23T00180L14	ELY.	100 $\mu$ F/25V
■	C236	08S40805F07	CER.	1000pF
■	C236	08S40805F07	CER.	1000pF

Symbol No	Part No	Description		
	E236	23T00180L14	ELY.	100 $\mu$ F/25V
	C237	08T57298F01	CER.	0.1 $\mu$ F
●	E237	23T00180L16	ELY.	330 $\mu$ F/25V
▲	E237	23T00180L16	ELY.	330 $\mu$ F/25V
◆	E237	23T00181L29	ELY.	330 $\mu$ F/25V
◇	E237	23T00181L29	ELY.	330 $\mu$ F/25V
■	E237	23T00181L29	ELY.	330 $\mu$ F/25V
□	E237	23T00181L29	ELY.	330 $\mu$ F/25V
■	C238	21C45322G32	CER.	0.022 $\mu$ F
□	C238	21C45322G32	CER.	0.022 $\mu$ F
●	C238	08T57298F01	CER.	0.1 $\mu$ F
▲	C238	08T57298F01	CER.	0.1 $\mu$ F
●	E238	23T00180L16	ELY.	330 $\mu$ F/25V
▲	E238	23T00180L16	ELY.	330 $\mu$ F/25V
◆	E238	23T00181L29	ELY.	330 $\mu$ F/25V
◇	E238	23T00181L29	ELY.	330 $\mu$ F/25V
■	E238	23T00181L29	ELY.	330 $\mu$ F/25V
□	E238	23T00181L29	ELY.	330 $\mu$ F/25V
	C239	08T94422F01	CER.	0.47 $\mu$ F
◆	C240	08T57851F13	TF.	0.1 $\mu$ F
◇	C240	08T57851F13	TF.	0.1 $\mu$ F
■	C240	08T57851F13	TF.	0.1 $\mu$ F
□	C240	08T57851F13	TF.	0.1 $\mu$ F
	E240	23T00180L08	ELY.	33 $\mu$ F/16V
	C241	08T00151L25	P.P	0.01 $\mu$ F
	E241	23T00180L08	ELY.	33 $\mu$ F/16V
	C242	08T00151L25	P.P	0.01 $\mu$ F
	C243	08T94422F01	CER.	0.47 $\mu$ F
	C244	08T94422F01	CER.	0.47 $\mu$ F
	E245	23T00180L08	ELY.	33 $\mu$ F/16V
	E246	23T00180L08	ELY.	33 $\mu$ F/16V
	C247	08T57298F01	CER.	0.1 $\mu$ F
	E247	23T00180L23	ELY.	3.3 $\mu$ F/50V
	C248	08T57298F01	CER.	0.1 $\mu$ F
	E248	23T00180L23	ELY.	3.3 $\mu$ F/50V
	E249	23T00180L25	ELY.	10 $\mu$ F/50V
◆	C250	08T94422F01	CER.	0.47 $\mu$ F
◇	C250	08T94422F01	CER.	0.47 $\mu$ F
■	C250	08T94422F01	CER.	0.47 $\mu$ F
□	C250	08T94422F01	CER.	0.47 $\mu$ F
	E250	23T00180L25	ELY.	10 $\mu$ F/50V
◆	C251	08T94422F01	CER.	0.47 $\mu$ F
◇	C251	08T94422F01	CER.	0.47 $\mu$ F
■	C251	08T94422F01	CER.	0.47 $\mu$ F
□	C251	08T94422F01	CER.	0.47 $\mu$ F

Note: ●:For Japanese model only (JA)  
▲:For General Foreign model only (EK)  
others:Common

◆:For American model only (UZ)  
■:For West Germany model only (AD)  
◇:For Canadian model only (UQ),  
□:For England model only (AG),

Symbol Na	Part Na	Description	
◆	E251	23T00180L24	ELY. 4.7 μF/50V
◇	C252	08T94422F01	CER. 0.47 μF
■	C252	08T94422F01	CER. 0.47 μF
□	C252	08T94422F01	CER. 0.47 μF
	E252	23T00180L24	ELY. 4.7 μF/50V
	E253	23T00180L23	ELY. 3.3 μF/50V
	E254	23T00180L23	ELY. 3.3 μF/50V
	E257	23T00180L24	ELY. 4.7 μF/50V
	E258	23T00180L24	ELY. 4.7 μF/50V
	E259	23T00180L26	ELY. 22 μF/50V
	E260	23T00180L26	ELY. 22 μF/50V
	E261	23T00180L26	ELY. 22 μF/50V
	E262	23T00180L26	ELY. 22 μF/50V
	C277	08T57705F59	MYL. 2200pF
■	C2290	08T44979P10	CER. 0.022 μF
□	C2290	08T44979P10	CER. 0.022 μF
Jacks			
	J201	09T84124F01	HEADPHONE
	S201		
	J202	09T15627W01	PLATE.PH1P
Coil			
●	L201	24T50508F22	Inductor, 10 μH
▲	L201	24T50508F22	Inductor, 10 μH
◆	L201	24T70381F21	Inductor, 10 μH
◇	L201	24T70381F21	Inductor, 10 μH
■	L201	24T70381F21	Inductor, 10 μH
□	L201	24T70381F21	Inductor, 10 μH
Resistars			
	R2201	06T74182F09	Block 270K ohm×15
	R2202	06T74182F08	Block 270K ohm×8
	VR201	18T15355W15	Variable RH064AC 22K ohm
	VR202	18T15355W09	Variable RH064AC 2.2Kohm
	VR203	18T15355W15	Variable RH064AC 22K ohm
	VR204	18T15355W15	Variable RH064AC 22K ohm
	VR205	18T15355W15	Varuible RH064AC 22K ohm
Trans			
	T201	25T94882F01	PULS
Crystals			
	X201	91T15285W01	Ceramic LOCK 4.19MHz
	X202	48T84727F02	AT-51 16.9344MHz

Note:●:For Japanese model only (JA)  
▲:For General Foreign model only (EK)  
others:Common

Symbol Na	Part Na	Description	
Power Supply P.C. Board			
IC's			
	IC101	51T80136F01	M5238P
	IC102	51T80136F01	M5238P
Transistors			
	Q101	48T64375F01	2SA1360
	Q102	48T60555F01	2SC3298
	Q103	48T57305F04	2SD1302
	Q104	48T57305F04	2SD1302
	Q105	48T57305F04	2SD1302
◆	Q106	48T57305F04	2SD1302
◇	Q107	48T57805F04	2SD1302
■	Q107	48T57805F04	2SD1302
□	Q107	48T57805F04	2SD1302
◆	Q108	48T57805F04	2SD1302
◇	Q108	48T57805F04	2SD1302
■	Q108	48T57805F04	2SD1302
□	Q108	48T57805F04	2SD1302
Diodes			
	D101	48S40477U01	1N4003
	D102	48S40477U01	1N4003
	D103	48S40477U01	1N4003
	D104	48S40477U01	1N4003
	D105	48S40477U01	1N4003
	D106	48S40477U01	1N4003
	D107	48S40477U01	1N4003
	D108	48S40477U01	1N4003
●	ZD101	48T52740F02	ZEN. HZ33-2
	ZD102	48T52739F95	ZEN. HZ27-2
▲	ZD102	48T52739F95	ZEN. HZ27-2
◆	ZD102	48T68697F72	ZEN. HZS27EB1
◇	ZD102	48T68697F72	ZEN. HZS27EB1
■	ZD102	48T68697F72	ZEN. HZS27EB1
□	ZD102	48T68697F72	ZEN. HZS27EB1
Capacitors			
●	C101	08T57437F09	CER. 0.01 μF
▲	C101	08T57437F09	CER. 0.01 μF
◆	C101	08T00196L01	CER. 0.01 μF
◇	C101	08T00196L01	CER. 0.01 μF
■	C101	08T00196L01	CER. 0.01 μF

◆:For American model only (UZ)  
■:For West Germany model only (AD)  
◇:For Canadian model only (UQ)  
□:For England model only (AG)

Symbol No	Part No	Description		
Capacitors				
□	C101	08T00196L01	CER.	0.01 μF
●	C102	08T57437F09	CER.	0.01 μF
▲	C102	08T57437F09	CER.	0.01 μF
◆	C102	08T00196L01	CER.	0.01 μF
◇	C102	08T00196L01	CER.	0.01 μF
■	C102	08T00196L01	CER.	0.01 μF
□	C102	08T00196L01	CER.	0.01 μF
	E101	23T00133L38	ELY.	470 μF/50V
	E102	23T00181L23	ELY.	3300 μF/16V
●	C103	08T50579F13	TF.	0.1 μF
▲	C103	08T50579F13	TF.	0.1 μF
◆	C103	08T57851F13	TF.	0.1 μF
◇	C103	08T57851F13	TF.	0.1 μF
■	C103	08T57851F13	TF.	0.1 μF
□	C103	08T57851F13	TF.	0.1 μF
	E103	23T00181L73	ELY.	100 μF/100V
◆	C104	08T94422F01	CER.	0.47 μF
◇	C104	08T94422F01	CER.	0.47 μF
■	C104	08T94422F01	CER.	0.47 μF
□	C104	08T94422F01	CER.	0.47 μF
	E104	23T00181L77	ELY.	470 μF/100V
	E105	23T00133L38	ELY.	470 μF/50V
	E106	23T00181L77	ELY.	470 μF/100V
	E107	23T00137L13	ELY.	33 μF/160V
	E108	23T00137L13	ELY.	33 μF/160V
◆	E109	23T00180L25	ELY.	10 μF/50V
◇	E109	23T00180L25	ELY.	10 μF/50V
■	E109	23T00180L25	ELY.	10 μF/50V
□	E109	23T00180L25	ELY.	10 μF/50V
◆	E110	23T00180L23	ELY.	3.3 μF/50V
◇	E110	23T00180L23	ELY.	3.3 μF/50V
■	E110	23T00180L23	ELY.	3.3 μF/50V
□	E110	23T00180L23	ELY.	3.3 μF/50V
	E111	23T00180L08	ELY.	33 μF/16V
	E112	23T00180L08	ELY.	33 μF/16V
	E113	23T00180L24	ELY.	4.7 μF/50V
	E114	23T00180L24	ELY.	4.7 μF/50V
Jacks				
	J101	09T15974W01	2P T6302-D105U	
	J102	09T15974W01	2P T6302-D105U	
Coil				
	L101	24T82315F01	LINE FK08160MH02	
Switch				
	S101	40T15820W01	PUSH POWER (Power)	

Note: ●:For Japanese model only (JA)  
 ▲:For General Foreign model only (EK)  
 others:Common

Symbol No	Part No	Description		
Volume Control				
VR101 MI01	18T10803W02	Volume, RK16313MA		
Remote P.C. Board				
IC				
IC501 or	51T16094W01 51T16094W02	GP1U521 GP1U521X		
Capacitor				
●	C501	08T57298F01	CER.	0.1 μF
▲	C501	08T57298F01	CER.	0.1 μF
◆	C501	08T44979P14	CER.	0.1 μF
◇	C501	08T44979P14	CER.	0.1 μF
■	C501	08T44979P14	CER.	0.1 μF
□	C501	08T44979P14	CER.	0.1 μF
LED				
LD501	48T60947F05	SLH-34VR3F (RED)		
Tube P.C. Board 1				
Resistors				
R705 R706	06T92261F26 06T92261F26	MF. 2.4 ohm 2W MF. 2.4 ohm 2W		
Tube P.C. Board 2				
Capacitors				
C401A	08T00019L10	MTL.	2.2 μF	
C401B	08T00019L06	MTL.	1 μF	
E401	23T00137L12	ELY.	22 μ F/160V	
C402A	08T00019L10	MTL.	2.2 μF	
C402B	08T00019L06	MTL.	1 μF	
E402	23T00137L12	ELY.	22 μ F/160V	
C403	08T00019L02	MTL.	0.22 μF	
C404	08T00019L02	MTL.	0.22 μF	
C405	08T00151L17	P.P	2200pF	
C406	08T00151L17	P.P	2200pF	
FL/Key Board P.C. Board				
Diodes				
D301	48T84758F01	1SS270		
D302	48T84758F01	1SS270		
D303	48T84758F01	1SS270		
D304	48T84758F01	1SS270		
D305	48T84758F01	1SS270		

◆:For American model only (UZ)  
 ■:For West Germany model only (AD)  
 ◇:For Canadian model only (UQ)  
 □:For England model only (AG)

Symbol No	Part No	Description		
0306	48T84758F01	ISS270		
0307	48T84758F01	ISS270		
0308	48T84758F01	ISS270		
0309	48T84758F01	ISS270		
0310	48T84758F01	ISS270		
0311	48T84758F01	ISS270		
0312	48T84758F01	ISS270		
Switchs				
S301	40T83324F11	Tact SKHHAP (REPEAT)		
S302	40T83324F11	Tact SKHHAP (6)		
S303	40T83324F11	Tact SKHHAP (0)		
S304	40T83324F11	Tact SKHHAP (A-PAUSE)		
S305	40T83324F11	Tact SKHHAP (7)		
S306	40T83324F11	Tact SKHHAP (1)		
S307	40T83324F11	Tact SKHHAP (A-SCN)		
S308	40T83324F11	Tact SKHHAP (8)		
S309	40T83324F11	Tact SKHHAP (2)		
S310	40T83324F11	Tact SKHHAP (M-CHECK)		
S311	40T83324F11	Tact SKHHAP (9)		
S312	40T83324F11	Tact SKHHAP (3)		
S313	40T83324F11	Tact SKHHAP (RANDOM)		
S314	40T83324F11	Tact SKHHAP (10)		
S315	40T83324F11	Tact SKHHAP (4)		
S316	40T83324F11	Tact SKHHAP (EDIT)		
S317	40T83324F11	Tact SKHHAP (+10)		
S318	40T83324F11	Tact SKHHAP (5)		
S319	40T83324F11	Tact SKHHAP (STOP)		
S320	40T83324F11	Tact SKHHAP (CLEAR)		
S321	40T83324F11	Tact SKHHAP (PAUSE)		
S322	40T83324F11	Tact SKHHAP (PROGRAM)		
S323	40T83324F11	Tact SKHHAP (PLAY)		
S324	40T83324F11	Tact SKHHAP (OPEN/CLOSE)		
S325	40T83324F11	Tact SKHHAP (SKIP+UP)		
S326	40T83324F11	Tact SKHHAP (BACKWORD)		
S327	40T83324F11	Tact SKHHAP (FORWORD)		
S328	40T83324F11	Tact SKHHAP (SKIP-DOWN)		
S329	40T83324F11	Tact SKHHAP (DISP.ADJ)		
S330	40T83324F11	Tact SKHHAP (TIME-DISP)		
Fade P.C. Board				
S901	40T83324F11	Tact SKHHAP (T.FADE-OUT)		
S902	40T83324F11	Tact SKHHAP (VOL.DOWN)		
S903	40T83324F11	Tact SKHHAP (VOL.UP)		
S904	40T83324F11	Tact SKHHAP (FADE-OUT)		

Symbol No	Part No	Description		
Miscellaneous				
●	C801	08T57298F01	Cap., Cer. 0.1 μF	
▲	C801	08T57298F01	Cap., Cer. 0.1 μF	
◆	C801	08T44979P14	Cap., Cer. 0.1 μF	
◇	C801	08T44979P14	Cap., Cer. 0.1 μF	
■	C801	08T44979P14	Cap., Cer. 0.1 μF	
□	C801	08T44979P14	Cap., Cer. 0.1 μF	
FL301	65T15386W01	FL, Display FV335G		
▲	F102	65T42077U11	Fuse, Semko 315mA	
■	F102	65T42077U11	Fuse, Semko 315mA	
□	F102	65T42077U11	Fuse, Semko 315mA	
IC105	51T16168W01	IC. μPC2412HF		
J801	09T66672F01	J90K, Head Phone		
●	P801	28T67434F01	Plug, AC Cord	
▲	P801	28T43812P04	Plug, AC Cord	
■	P801	28T43812P04	Plug, AC Cord	
□	P801	28T44061F05	Plug, AC Cord	
◆	P801	28T55335F02	Plug, AC Cord	
◇	P801	28T55335F02	Plug, AC Cord	
Q701	65T00091L01	Tube (6CG7)		
Q702	65T00091L01	Tube (6CG7)		
R601	06T92262F23	Res, MF 1.8 ohm 3W		
R602	06T92262F23	Res, MF 1.8 ohm 3W		
S601	40T15685W01	SW. Push (Pre-Heat)		
●	T101	25T16178W01	Trans, Power	
▲	T101	25T16178W02	Trans, Power	
■	T101	25T16178W02	Trans, Power	
□	T101	25T16178W02	Trans, Power	
◆	T101	25T16178W03	Trans, Power	
◇	T101	25T16178W03	Trans, Power	

Note : ● : For Japanese model only (JA)  
 ▲ : For General Foreign model only (EK)  
 Other : Common

◆ : For American model only (UZ)  
 ■ : For West Germany model only (AD)  
 ◇ : For Canadian model only (UQ)  
 ■ : For England model only (AG)

# Exploded View(Cabinet)

- Note :
- ◇ ; For Canadian model only (UQ)
  - ; For England model only (AG)
  - ◆ ; For American model only (UZ)
  - ; For West Germany model only (AD)
  - ▲ ; For General Foreign model only (EK)
  - ; For Japanese model only (JA)
  - Others ; Common

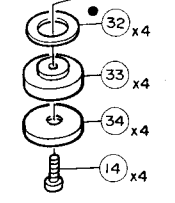
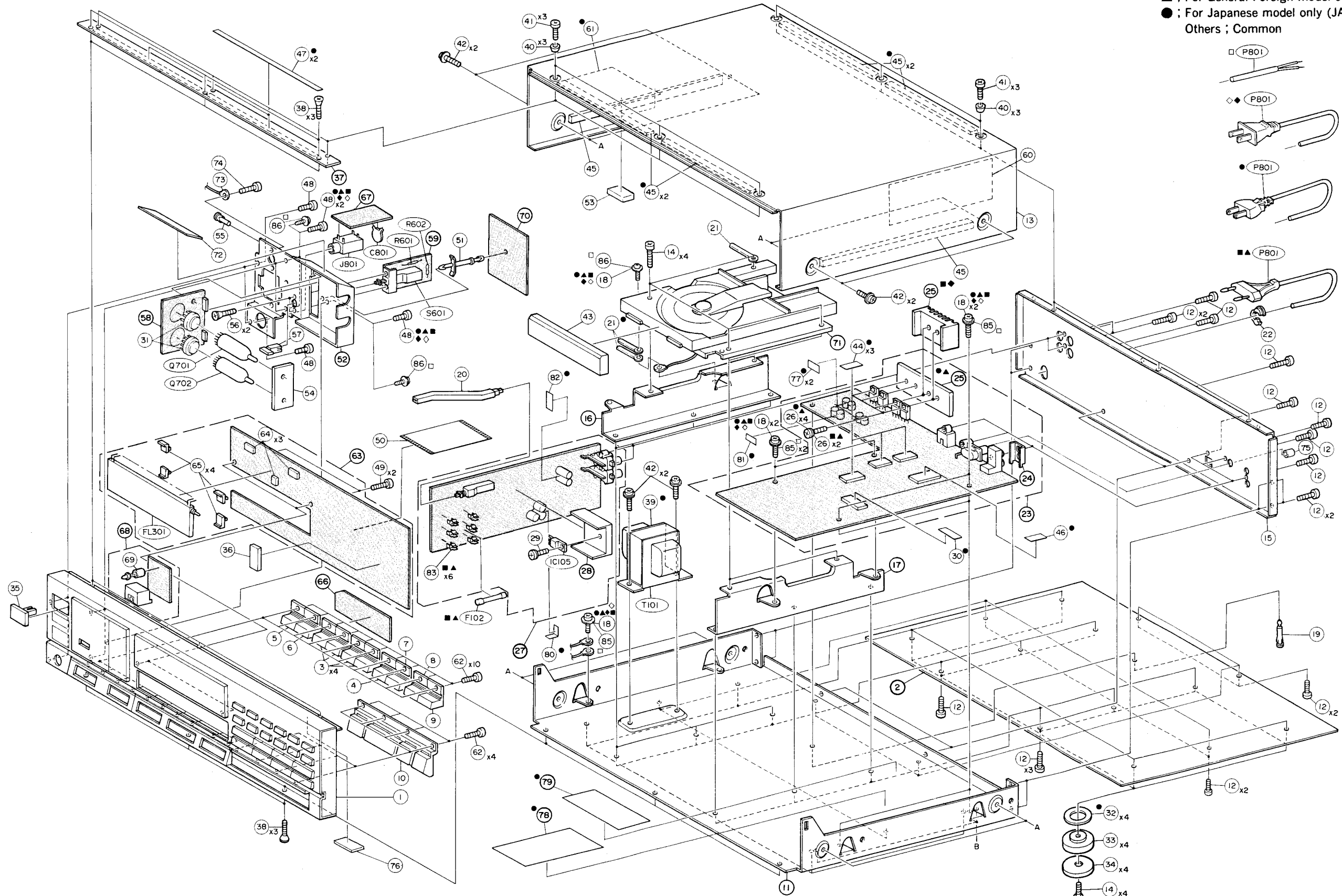
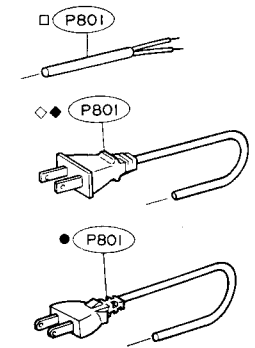

1  
2  
3  
4  
5

A | B | C | D | E | F | G | H



# Packing Assembly Parts List

Symbol No	Part No	Description
●	101-1	68P96552F25 Owners, Manual
◆	101-1	68P96552F26 Owners, Manual
◇	101-1	68P96552F27 Owners, Manual
▲	101-1	68P96552F27 Owners, Manual
■	101-1	68P96552F27 Owners, Manual
□	101-1	68P96552F27 Owners, Manual
	101-2	01T82091F01 Assy., Mini Plug Cord
●	101-3	01T16150W01 Unit, Remocon
▲	101-3	01T16150W02 Unit, Remocon
■	101-3	01T16150W02 Unit, Remocon
◆	101-3	01T16150W02 Unit, Remocon
◇	101-3	01T16150W02 Unit, Remocon
□	101-3	01T16150W02 Unit, Remocon

Symbol No	Part No	Description
	101-4	60T58064F01 Battery, SUM-3
	101-5	28T67347F04 Plug, Output
◆	101-6	01T84773F01 Fiber, TOCP172-150CB
◇	101-6	01T84773F01 Fiber, TOCP172-150CB
■	101-6	01T84773F01 Fiber, TOCP172-150CB
●	102	56S10005W27 Carton, Packing
◆	102	56S10005W27 Carton, Packing
▲	102	56S10005W27 Carton, Packing
■	102	56S10005W27 Carton, Packing
□	102	56S10005W27 Carton, Packing
◇	102	56S10005W28 Carton, Packing
	103	56B40442T08 Packing, Front Frame
	104	56D11887W01 Tray, Packing

Note : ● : For Japanese model only (JA)  
 ▲ : For General Foreign model only (EK)  
 Others : Common

◆ : For American model only (UZ)  
 ■ : For West German model only (AD)  
 ◇ : For Canadian model only (LQ)  
 □ : For England model only (AG)

# Packing Method View

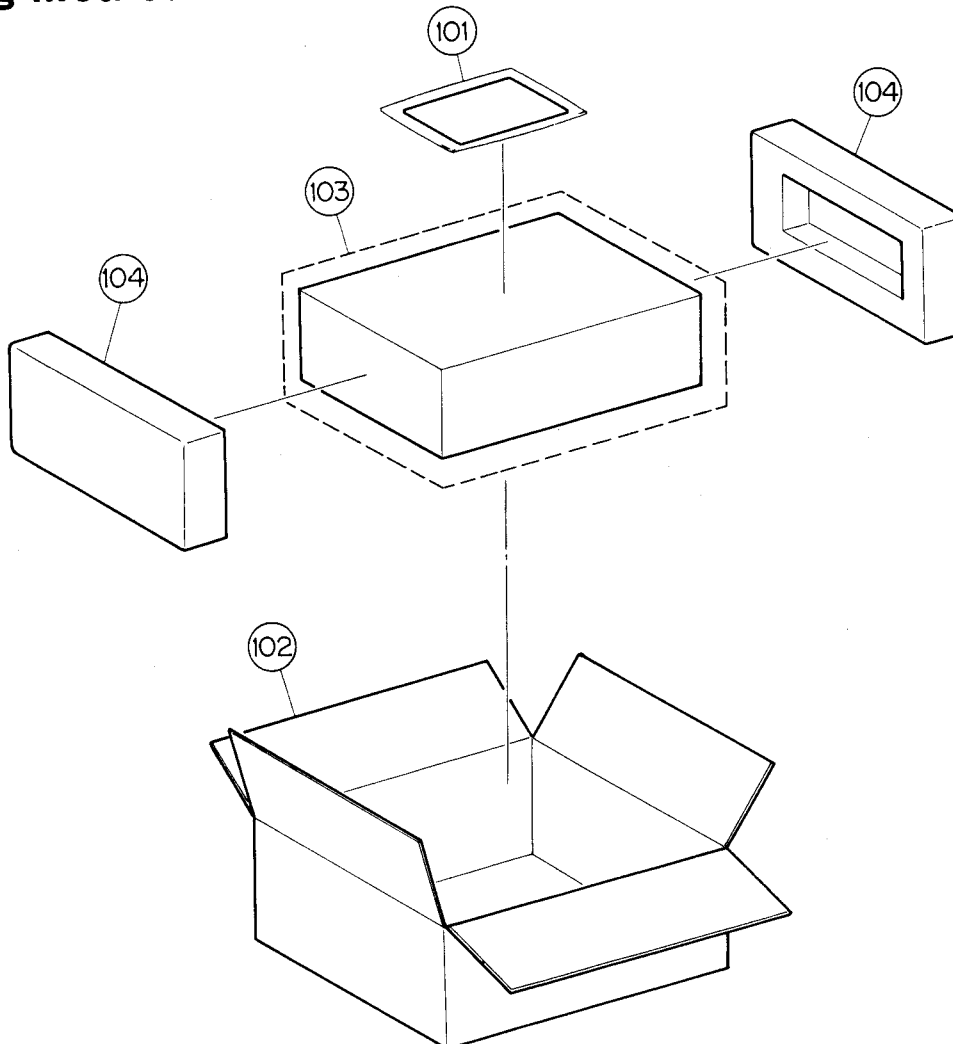



## Semi-Conductor Lead Identifications

**M5238P : IC101, 102**

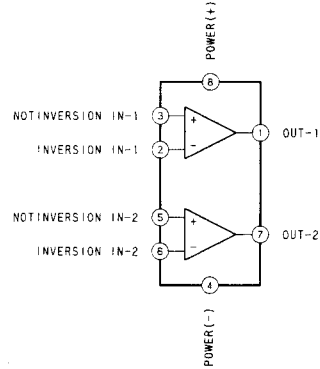
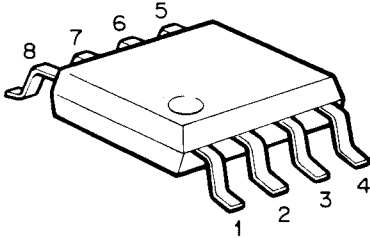

**μPC2412HF : IC105**

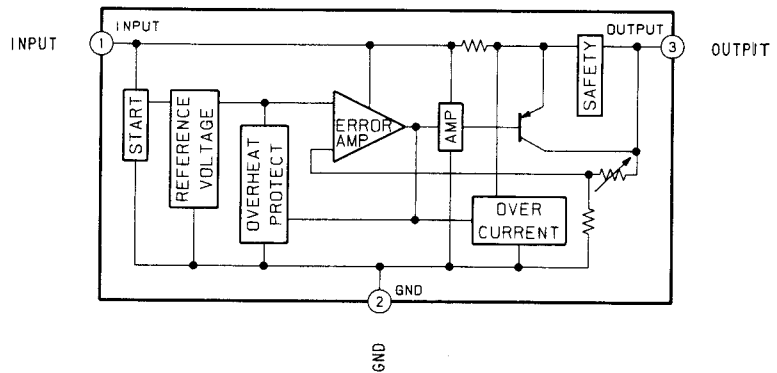
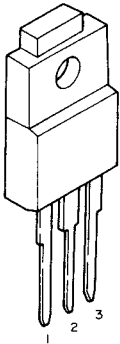

**15365W02 : IC201 (JA/EK Model only)**

**15749W02 : IC201 (AD/UZ/AG/UQ Model only)**

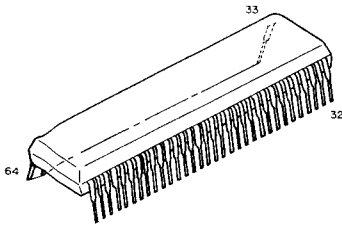

1	SEG4	17	EMPHA	33	SQ CK	49	OSC
2	SEG3	18	GFS	34	SUBQ	50	GND
3	SEG2	19	-35V	35	FOK	51	GND
4	SEG1	20	A.MUTE	36	PWM	52	NC
5	SEG0	21	CLOSE SW	37	SENS	53	+5V
6	DIG0(1G)	22	OPEN SW	38	NC	54	VOL CP
7	DIG1(2G)	23	LD ON	39	MUTE	55	VOL UP
8	DIG2(3G)	24	XRST	40	RHT SW	56	VOL DOWN
9	DIG3(4G)	25	XLT	41	CLOSE	57	SEG12
10	DIG4(5G)	26	DATA	42	OPEN	58	SEG11
11	DIG5(6G)	27	CLK	43	SWRTN	59	SEG10
12	DIG6(7G)	28	POWER	44	KRTN2	60	SEG9
13	DIG7(8G)	29	SCOR	45	KRTN1	61	SEG8
14	DIG8(9G)	30	RMC	46	KRTN0	62	SEG7
15	DIG9(10G)	31	NC	47	RESET	63	SEG6
16	DIMM	32	+5V	48	OSC	64	SEG5

CXA1082BS : IC202

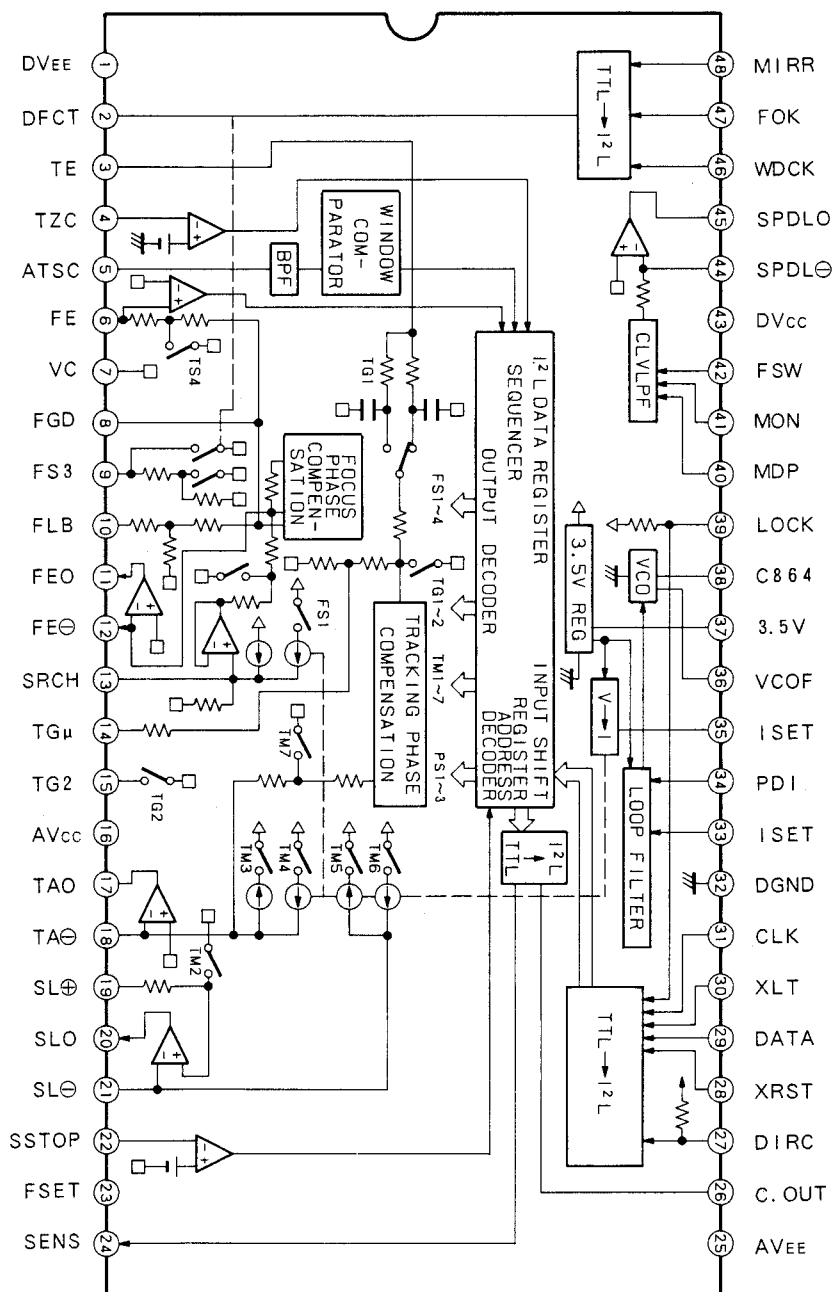
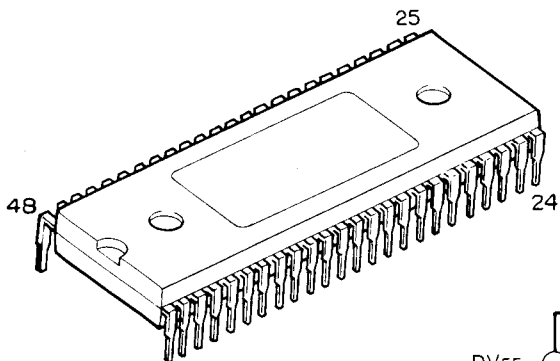

CXA1081S : IC203

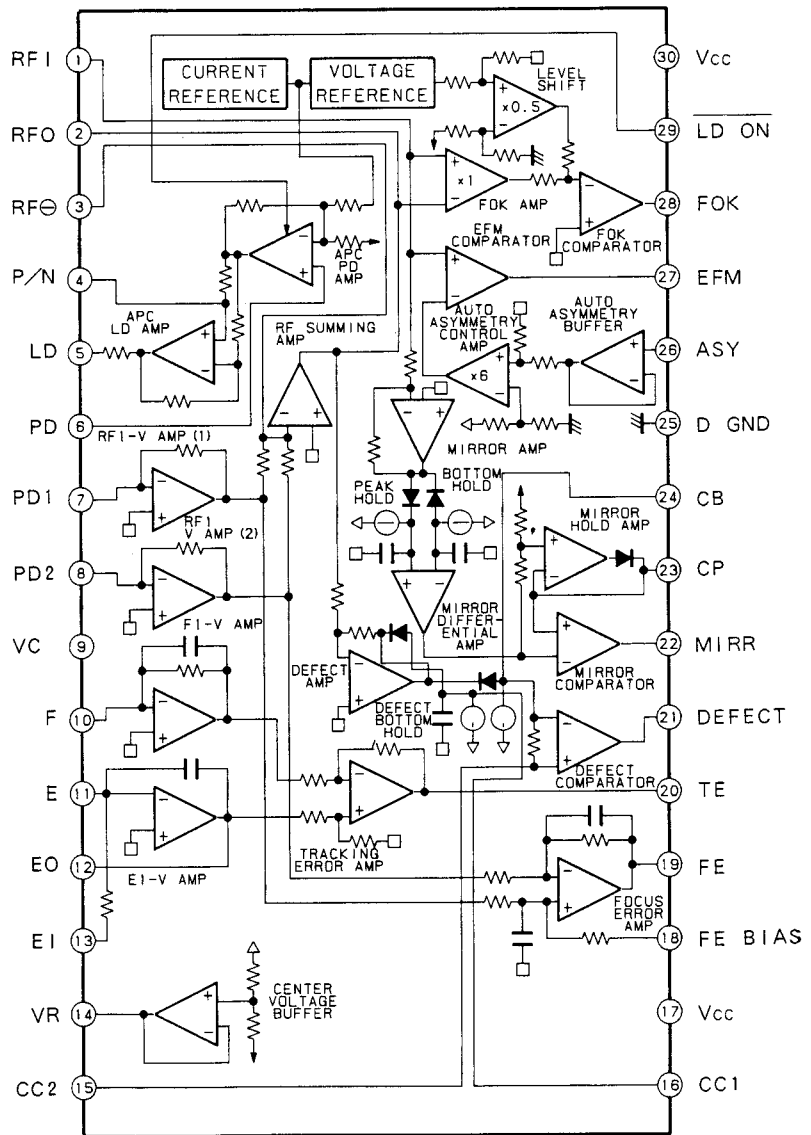
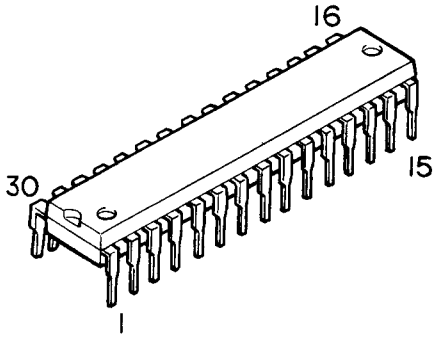

**MC14053 : IC204 (JA/EK Model only)**

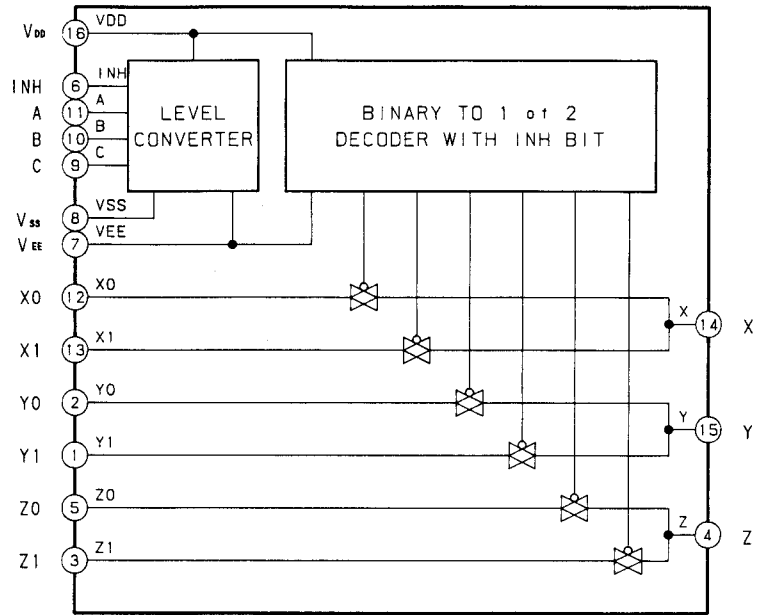
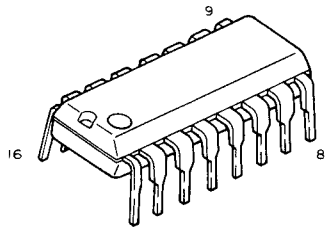

**STA341M : IC204 (AD/UZ/AG/UQ Model only)**

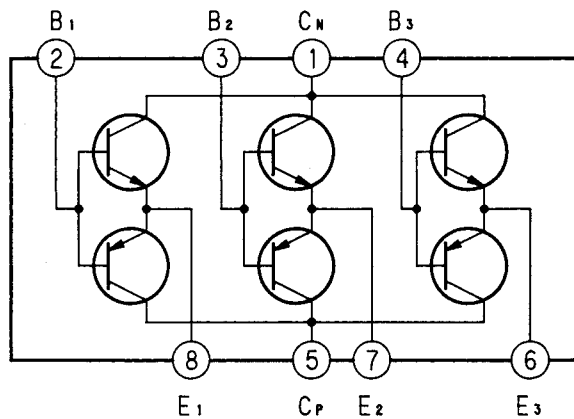
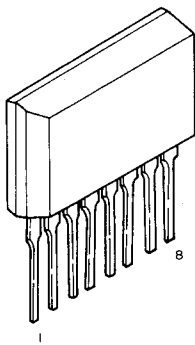

**B. Base**  
**C. Collector**  
**E. Emitter**

CXD1125QZ : IC205

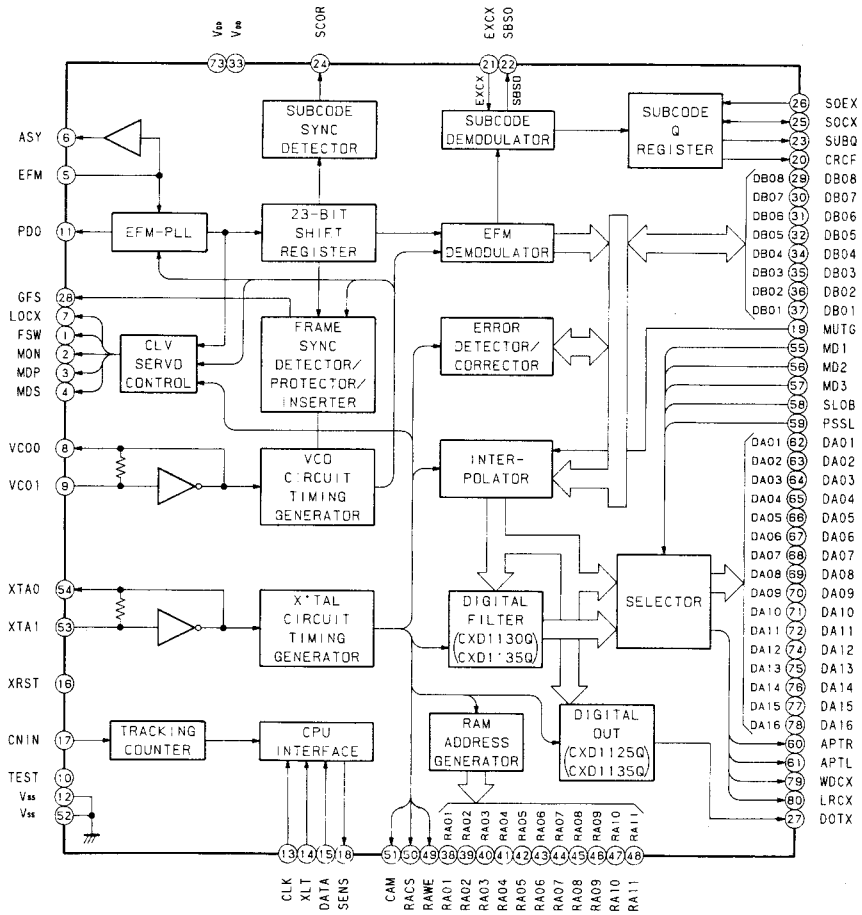
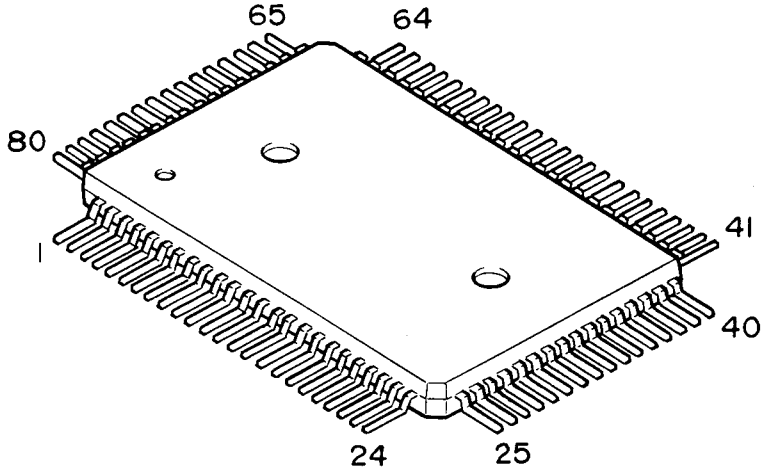

**LC3516AS : IC206**

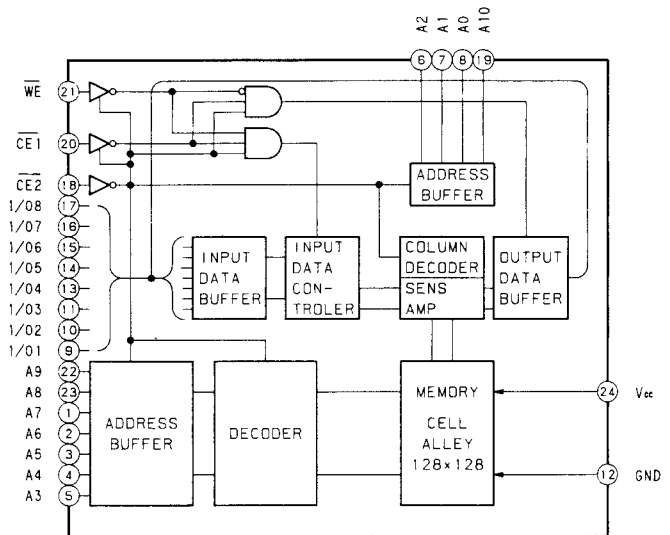
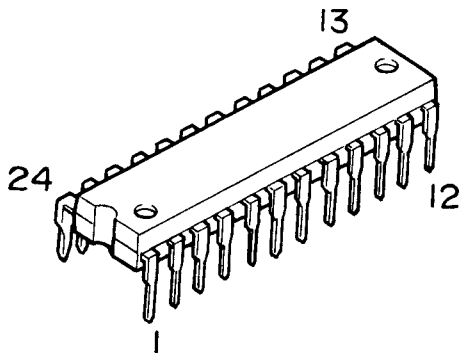

**MC74HCU04 : IC207**

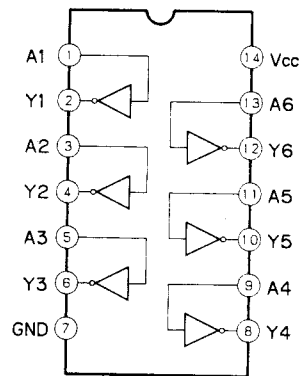
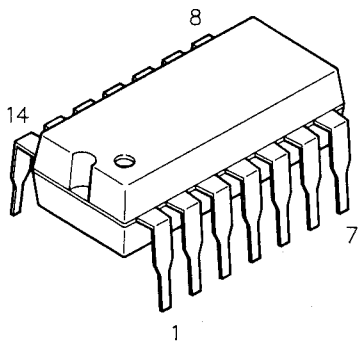

**HFBR1550 : IC208**

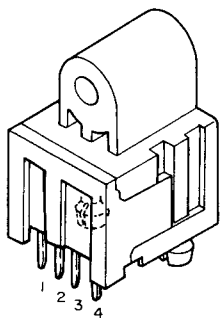

	Transmitter	Receiver
1	LED-Anode	V <sub>ccd</sub>
2	LED-Cathode	V <sub>OUT</sub>
3	N.C	GRD
4	N.C	V <sub>cca</sub>

**SM5813AP : IC209**

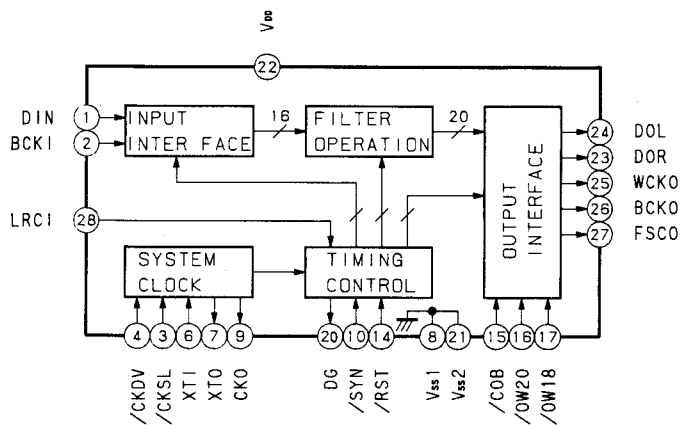
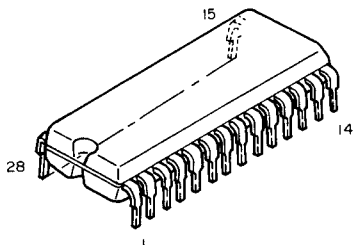

**NJM2903D : IC210 (JA/EK Model only)**

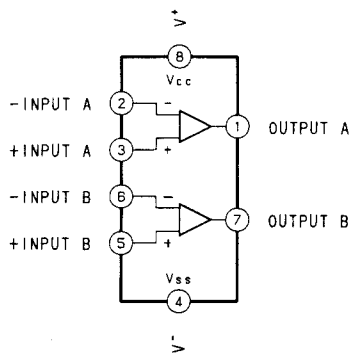
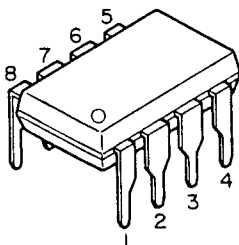

**NJM2903S : IC210 (AD/UZ/AG/UQ Model only)**

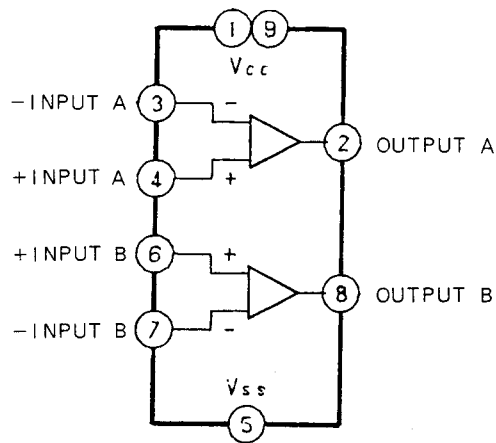
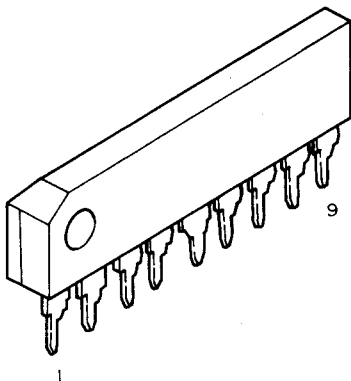

**PCM701P : IC211, 212**

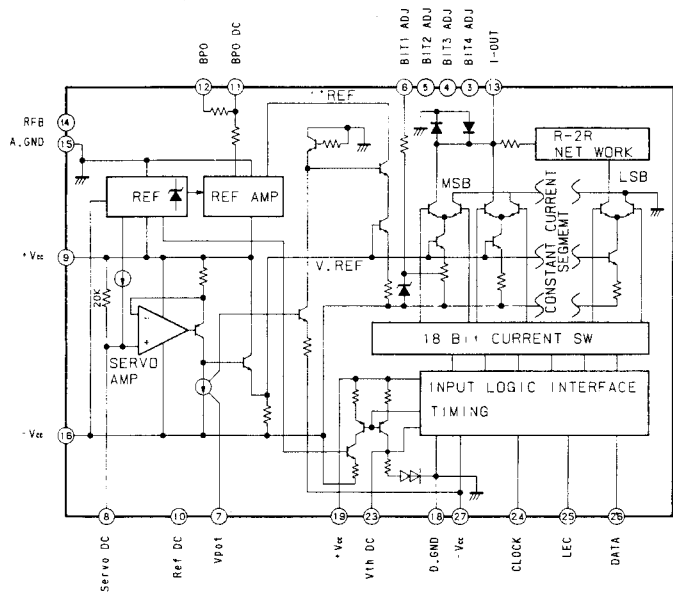
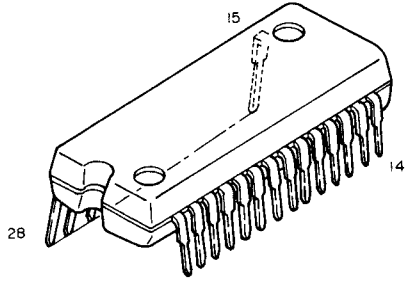

**LA6501 : IC213, 218**

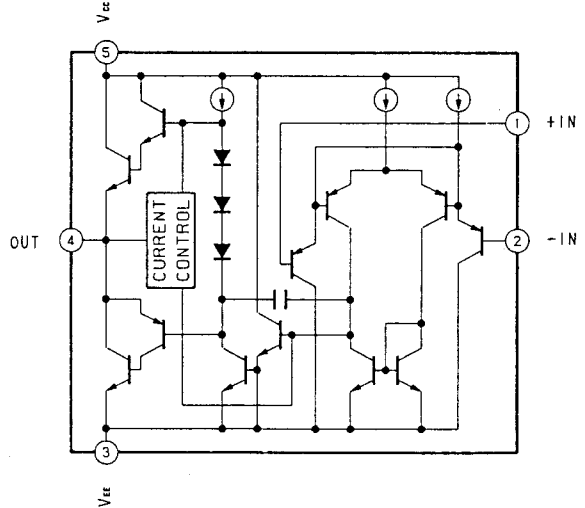
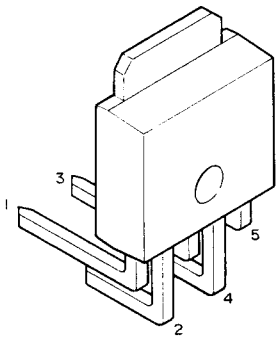

**NJM7805 : IC214**

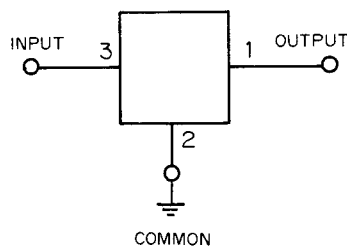
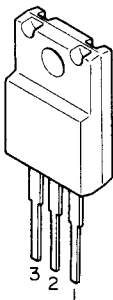

- 1. Output
- 2. Common
- 3. Input



**NJM7905 : IC215, IC217**

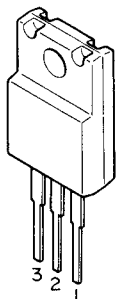

- 1. Output
- 2. Input
- 3. Common

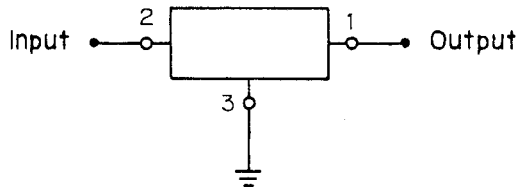

**NJM7808 : IC216 (JA/EK Model only)**  
**NJM7808FA : IC216 (AD/UZ Model only)**

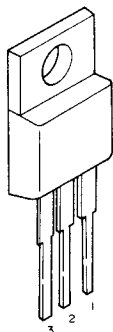

- 1. Output
- 2. Common
- 3. Input

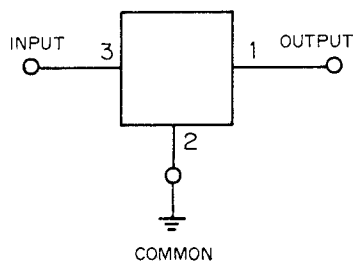

**M5238L : IC219, 220**

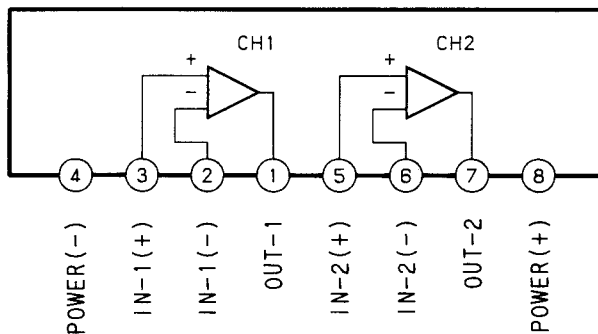
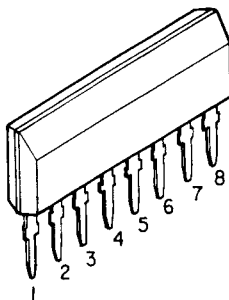

**NJM78L05A : IC221**

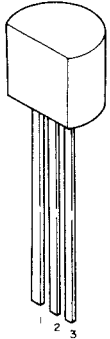

- 1. Output
- 2. GND
- 3. Input

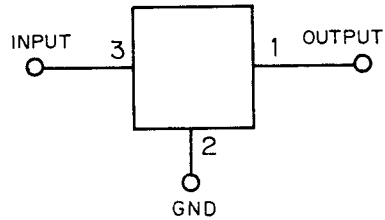

**GP1U521 : IC501**  
or **GP1U521X**

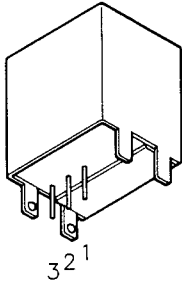

- 1.  $V_{OUT}$
- 2.  $V_{CC}$
- 3. GND

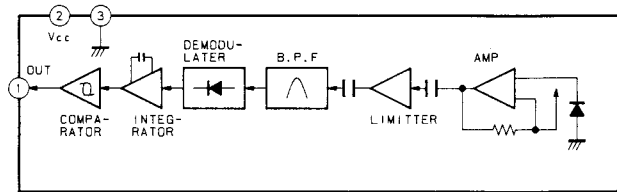

- 2SA1360 : Q101**
- 2SC3421 : Q212**  
: Q214, 216, 218 (JA/EK Model only)
- 2SA1358 : Q213**  
: Q215, 217, 219 (JA/EK Model only)

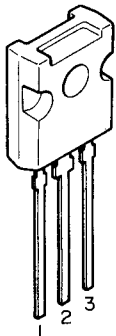

- 1. Emitter
- 2. Collector
- 3. Base

**2SC3298 : Q102**

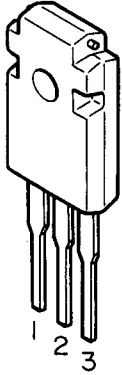

- 1. Base**
- 2. Collector**
- 3. Emitter**

**2SD1302 : Q103, 104, 105, 106, 221, 222**  
 : Q107, 108 (AD/UZ/AG/UQ Model only)  
**2SA854Q : Q201**  
**2SA950 : Q223 (AD/UZ/AG/UQ Model only)**

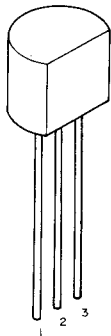

- 1. Emitter**
- 2. Collector**
- 3. Base**

**DTC114EL : Q204, 207, 208, 209**  
 : Q224, 225 (AD/UZ/AG/UQ Model only)

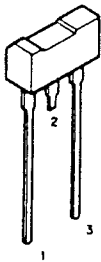

- 1. Emitter**
- 2. Collector**
- 3. Base**

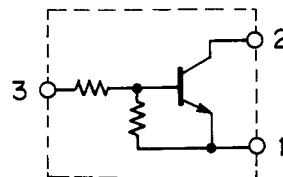

**DTA114EL** : Q205, 206

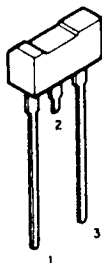

- 1. Emitter
- 2. Collector
- 3. Base

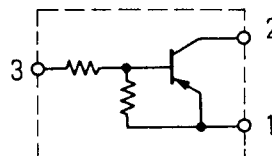

**2SC4038** : Q210, 211  
**2SB1277** : Q220

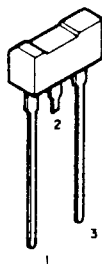

- 1. Emitter
- 2. Collector
- 3. Base

**DTC124TL** : Q226 (AD/UZ/AG/UQ Model only)

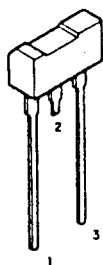

- 1. Emitter
- 2. Collector
- 3. Base

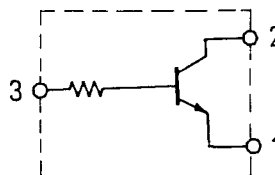



## **LUX CORPORATION, JAPAN**

1-1-8 Nishi Gotanda, Shinagawa-ku, Tokyo, 141 JAPAN  
Phone: 03-493-4381 Facsimile: 03-494-8426

7/89-Y  
68P20520W02  
Printed Japan